



徐工集团徐州重型机械有限公司
XCMG XUZHOU HEAVY MACHERY CO.,LTD.



NEW

□ QAY180 QAY220 □ QAY260 □ QAY300 □ QAY400 □ QAY500

全地面起重机
All Terrain Crane



徐工重型 新一代王者时代 引爆中国轮式起重机第五次革命

中国工程起重机行业技术变革之路

从1963年，中国推出第一代汽车起重机，此后，徐工连续五次引领行业技术变革。

70年代，徐工率先进入全液压汽车起重机领域，掀起了中国起重机行业的第一次技术革命；

2000年，徐工推出的K系列汽车起重机开创了一个全新时代；

2002年，中国首台全地面起重机在徐工诞生，中国从此步入高端起重机领域，徐工再一次站在了行业的制高点；

2004年徐工重型突破封锁、自主创新，成功掌握“U形”、“单缸插销自动伸缩”两项技术，给汽车起重机行业

再一次引发了革命，给中国装备制造业添加了绚烂的一笔；

2010年上半年，徐工全面启动边界极限工程，接连推出三大系列新品，一举引爆行业第五次技术革命。

XCMG Xuzhou Heavy Machinery Co., Ltd. (XZHM)

NEW GENERATION KING'S TIME IGNITES THE 5TH WHEEL MOUNTED CRANE REVOLUTION IN CHINA

The technological innovation way of Chinese construction crane industry

In 1963, China introduced the first generation truck crane. Afterwards, XCMG has led the industry technological innovation successively for five times .

In the 1970' s, XCMG took the lead in getting into Full hydraulic truck crane field, which set off the first technological innovation in Chinese crane industry .

In 2000, K series Truck cranes introduced by XCMG created a completely new time .

In 2002, the first Chinese All Terrain Crane was born in XCMG, from then on China stepped into the high-end crane field, and XCMG run in the most front among the domestic industry players once again .

In 2004, XCMG successfully mastered "U" -shaped, "single cylinder pin automatically telescoping" boom technologies after breaking blockage and performing self-innovation, which sparked another technological revolution in Chinese truck crane industry, and added a splendid stroke to Chinese equipment manufacture industry .

In the first half of 2010, XCMG initiated "boundary limit" project comprehensively, and launched three series products successively, which ignited the 5th technological revolution in the industry .



八大技术亮点 EIGHT TECHNOLOGICAL HIGHLIGHTS

徐工全地面起重机拥有222项专利技术 采用38项全新专利技术

XCMG All Terrain Crane possesses 222 patent technologies, and adopts 38 completely new patent technologies.

新型单缸伸缩臂技术

New single cylinder telescoping boom technology

吊臂伸缩平顺可靠、安全性更高、进一步提升起重作业的稳定性和承载能力

Boom telescopes smoothly and reliably with higher safety, and the stability and load-bearing ability during lifting operation are improved further.

先进的驱动装置

Advanced driving devices

环保、强劲、高效

Environmental, powerful and effective

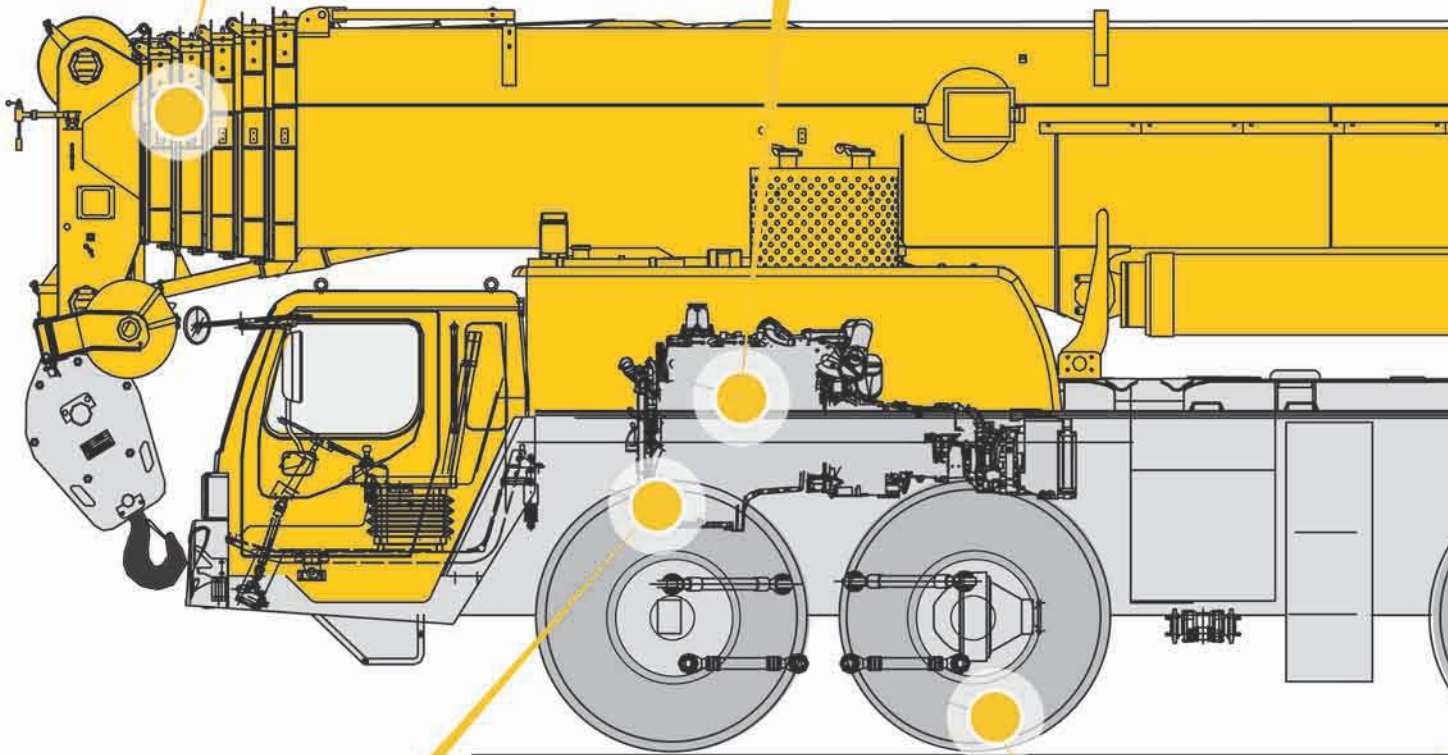

油气悬架技术

Hydro-pneumatic suspension technology

整车行驶平顺，通过性能优越

Entire vehicle drives smoothly with excellent passing ability

多轴多模式电液转向技术

Multi-axle various modes electro hydraulic steering technology

六种转向模式，车辆更灵活

Six steering modes contribute to excellent maneuverability

QAY220

徐工集团全地面起重机 XCMG ALL TERRAIN CRANE

智能化操作系统

Intelligent control system

全方位智能化控制，操作更轻松便利
Overall intelligent control system brings more easy and convenient operation

自组合式平衡重技术

Self-assembled technology of counterweight

可完成近3万个吊重工况，最大满足施工需求
Almost 30,000 lifting applications may be implemented with the help of it, construction demands are met maximally

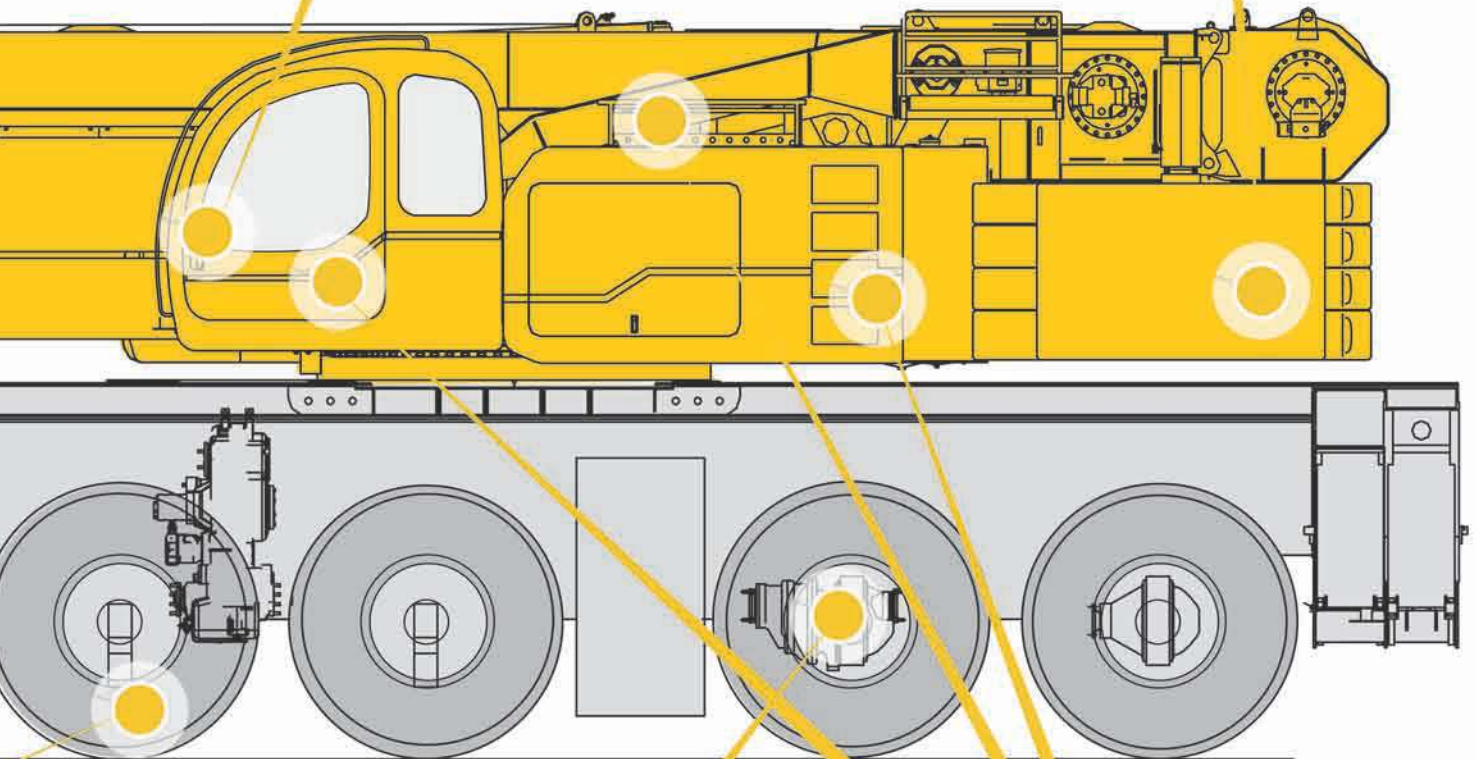

新型制动技术

New brake technology

降低维护保养成本三分之二，延长使用寿命，
制动更安全可靠
Maintenance cost is reduced two thirds, service life is prolonged, and brake is more safe and reliable

全方位人性化设计

Overall ergonomic design

想您所想，轻松吊装
Taking what costumers want into consideration as well as easy lifting operation

紧凑/灵活/重量优化

Compact/maneuverable/weight-optimized

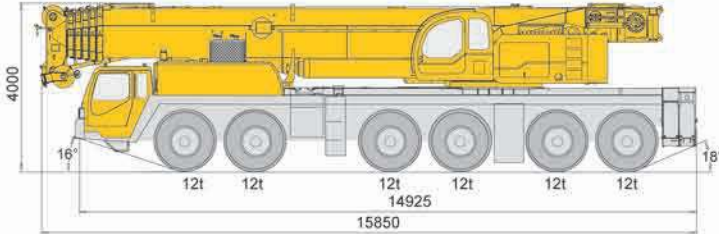

- 行驶状态全长仅15.85m，底盘长度仅14.925m。
- 接近角为16°，离去角为18°。
- 全桥转向时，最小转弯半径仅为11.5m。
- 行驶状态总重量仅72t，轴重6×12t。
- 全配置还包括6节64m主臂，4节36m副臂，65t配重，5种配重组合可完成近3万个工况。
- Entire length just 15.85m, and carrier length 14.925m in travel configuration.
- Approach angle is 16°, departure angle is 18°.
- The minimum turning radius is 11.5m during all-axle steering.
- Total vehicle weight in travel configuration is only 72t, and axle load 6×12t.
- Six-section telescopic boom extending to 64m, four-section jib extending to 36m, and 65t counterweight are standard equipments, 5 counterweight variants contribute to approximate 30,000 lifting applications.

先进的驱动装置

Advanced driving devices

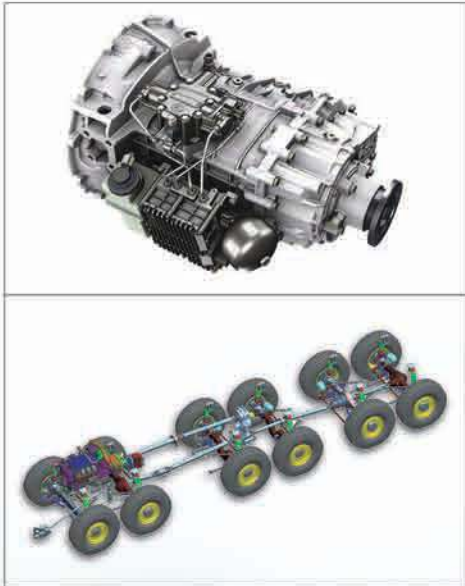

- 发动机采用动力系统强劲的进口奔驰电喷发动机（额定功率：420kw/1800rpm；最大扭矩：2700Nm/1300rpm）。
- 变速箱采用进口16档自动操纵变速箱，带缓速制动及取力器。
- 分动箱采用进口大降距分动箱，带高低档，差速器及取力接口。
- 动力系统散热采用风冷、水冷和油冷相结合，散热器平置在发动机右侧，采用液压驱动风扇工作，同时发动机前端仍保留风扇，吸入冷风为机体表面降温。
- 驱动形式为12×6 第二、五、六桥为驱动桥。
- 转向形式为12×12 全桥转向。
- 最高车速72Km/h。
- 最大爬坡度50%。
- Benz powerful electronic injection engine (rated power of 420kw/1800rpm, max. torque of 2700Nm/1300rpm).
- Imported 16-speed automatic control transmission with retarder and PTO.
- Imported transfer box with high/low speed, ports of differential and PTO.
- Air cooling, water cooling and oil cooling are combined for heat dispersion of power system. With fan driven hydraulically, radiator is horizontally positioned at the right side of engine, and the fan located in the front end of the engine is retained for sucking cold air to lower the temperature of the engine block.
- Drive 12×6, 2nd, 5th and 6th axles are for driving.
- Steering 12×12, all axles steering.
- Maximum vehicle speed is 72Km/h.
- Maximum grade ability is 50%.



新型单缸伸缩臂技术

New single cylinder telescoping boom technology

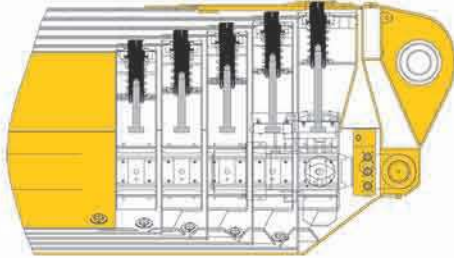

- 6节伸缩臂总长64m。
- 采用高强度进口钢材，自重更轻，性能更强。
- 椭圆形截面，变截面技术，抗扭强度大，稳定性高。
- 快速自动伸缩系统提高作业效率。
- 优化的多种伸缩组合方式，最大限度的发挥起重臂性能。
- 高强度耐磨滑块。
- Six-section telescopic boom up to 64m.
- Made of high tensile imported steel, lighter dead weight and stronger capacity.
- Oval cross-section and tapered cross-section technology contribute to larger torsion-resistant strength and higher stability.
- Fast automatically telescoping system improves operating efficiency.
- Various configurations of telescoping boom are optimized, which give free rein to its lifting capacity maximally.
- High strength wear sliders are available.

自组合平衡重技术

Self-assembled technology of counterweight

- 自主研发的组合式平衡重技术，能有效提升中长臂吊重性能30%。
- 整个安装过程自我完成，无需其他设备配合，方便快捷。
- 采用全新平衡重挂接方式。
- 平衡重组合安装只需30分钟，极大地提高工作效率。
- Self-assembled technology of counterweight researched & developed by ourselves, improves 30% the lifting capacity of medium-length boom effectively.
- Whole assembling process is finished by itself, no need for other equipment, convenient and quick.
- Completely new assembling method is used.
- Only 30 minutes is enough for assembly, the working efficiency is improved greatly.

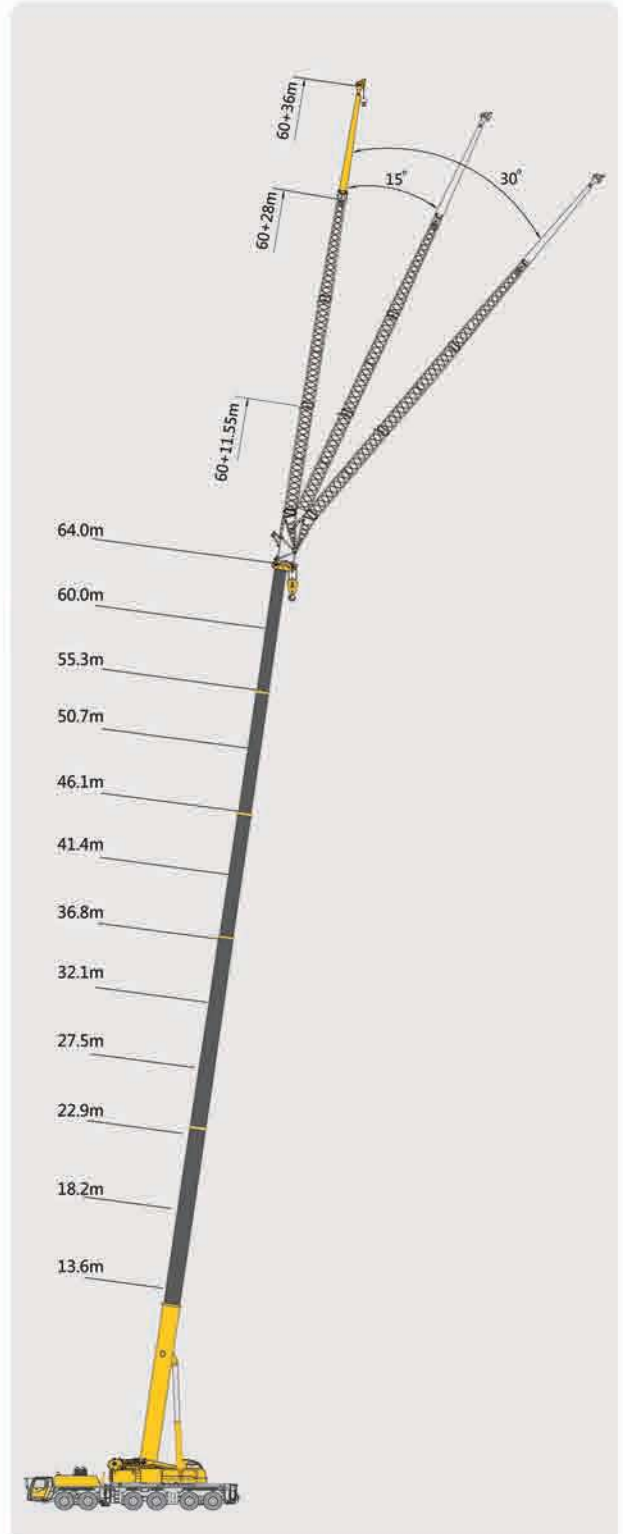
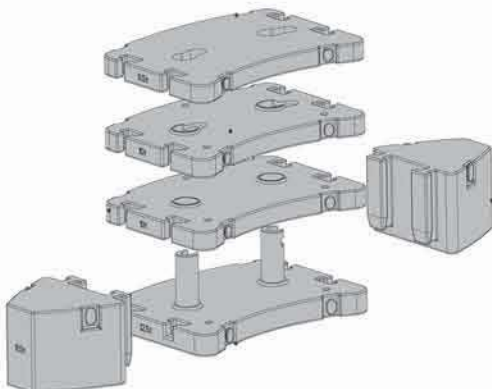

电液比例控制多桥转向模式

Electro hydraulic proportional control multi-axle steering modes

前轴采用机械控制+液压助力转向，后轴采用电液比例控制转向，可单独控制转向和锁死，实现多种转向工作模式。
Front axle employs mechanical control plus hydraulic servo steering, and rear axle takes electro hydraulic proportional control steering. Steering and locking of axles may be controlled individually for various steering modes.

公路行驶模式 ROAD TRAVEL MODE

车辆可根据自身行驶状态，自动选择不同的转向形式，以实现车辆在任何情况下的最安全行驶。
Road travel mode: the vehicle may select different steering modes automatically according to its travel condition so as to realize the safest driving in any condition.

小转弯模式 SMALL TURNING MODE

可在空间不开阔的场地实现较小的转弯直径。
Small turning mode: in order to perform turning with a small diameter in a confined job site.

蟹行行驶模式 CRAB WALK MODE

可使车辆平行斜行。后轴采用与前轴基本相同的转向角度，使整车能横向移动，快速到达施工场所。
Crab walk mode: the crab walk is realized when the front axle and the rear axle are steering towards the same direction, so that the vehicle gets the job site quickly.

后轴独立转向模式 REAR AXLE INDEPENDENT STEERING MODE

在狭小场地倒车使用后轴，前轴由方向盘控制转向，后轴可参照前桥的转向角度通过一个按钮可实现独立转向，能够在狭小的空间进出自如。
Rear axle independent steering mode: for reversing in a job site where space is restricted. While front axle is steered by the steering wheel, rear axle steering is performed by a button with reference to the front axle steering angle, so free coming in and out of a confined job site is available.

后轴锁定模式 REAR AXLE LOCKED

可选择后轴是否转向，机动性能突出。
Rear axle locked mode: it is used to select rear axle steering or not for good maneuverability.

防甩尾模式 ANTI-DRIFTING MODE

最后轴不转向，增强高速行驶的稳定性，确保行驶安全。
Anti-drifting mode: the last axle is not steering, which will increase the vehicle stability during its high speed driving, and driving safety is ensured.

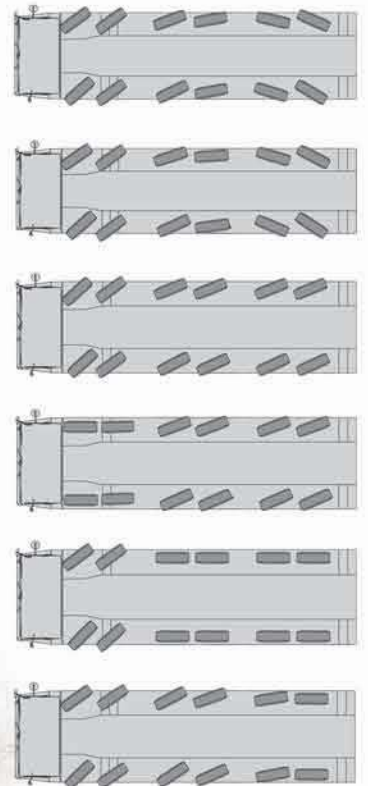

新型制动技术

New brake technology

- 采用行车制动+驻车制动+辅助制动结合的制动系统。
- 行车制动采用双回路系统，并配备ABS防抱死制动系统。
- 辅助制动有发动机缓速制动和变速箱缓速制动，并通过制动综合管理提高制动系统的安全性和舒适性。
- 车轴采用气盘式制动器，为国内同行业首次应用。
- 降低维护成本2/3，提高行车安全。
- The brake system consists of service brake, parking brake and auxiliary brake.
- Service brake adopts dual circuit system, with ABS equipped.
- Auxiliary brake includes engine retarder and transmission retarder. Safety and comfort in brake system are improved by brake comprehensive management.
- Air disc brake is used in axle, which is employed first in domestic same industry.
- Maintenance cost is reduced two thirds, and driving safety is improved.

油气悬架技术

Hydro-pneumatic suspension technology

- 可实现车辆的上升、下降、手动及自动调平、弹性与刚性转换，使车辆能够轻松通过涵洞、桥梁等限高场所。
- 缓和冲击载荷，起到衰减振动的作用，保证车辆具有良好的行驶平顺性和通过性，提高了乘坐舒适性。
- 双纵臂导向，约束轴的运动轨迹。
- 实现车辆的操纵稳定性，上车始终保持平稳。
- Vehicle up and down movement, manual and automatic leveling, switch-over of flexible and rigid suspension may be realized with it, so the vehicle may freely pass culvert, bridge and low underpasses.
- Shock load may be buffered, taking the role of damping vibration, therefore, driving smoothness and pass ability are available, and driver's comfort is improved.
- Imported transfer box with high/low speed, ports of differential and PTO.
- Dual longitudinal push rods are to confine the path of axle motion.
- Vehicle operation stability is ensured, and superstructure smoothness is kept.

全方位人性化设计

Overall ergonomic design

起重机支腿操作

OUTRIGGER OPERATION

- 不同的支撑位置
支腿完全缩回
半伸位置：6.5m×8.8m
全伸位置：8.7m×8.8m
- 支脚盘固定安装，由防护罩保护。
- 支腿水平调整，仅需通过一个按钮即可自动将起重机调至水平状态。
- 底盘两侧都有支腿控制面板，具有形象识别的键盘、电子水平仪、以及“发动机启动、停止”按钮和速度控制键，均可发光显示并可锁定。
- 支腿的操作过程严格按照程序设定，防止事故发生。
- 由四个工作灯向支腿区域提供照明。
- Various supporting positions
Outriggers are retracted fully
Half-extended outrigger span: 6.5m×8.8m
Fully-extended outrigger span: 8.7m×8.8m
- Outrigger floats are fixed permanently and protected by protective covers.
- The vehicle may be leveled automatically only by pressing a button.
- On both sides of carrier there is an outrigger control console individually, on which there are a key board and an electronic level gauge. Engine start and stop buttons as well as speed control keys with pictograms on the key board are indicated luminously and deactivated by an enable switch.
- Outrigger operating procedure is set strictly according to programs to prevent accident occurring.
- There are four working lamps for supplying illumination to outrigger area.

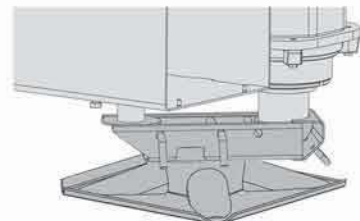

舒适的上车操纵室

COMFORTABLE
OPERATOR'S CAB

- 大圆弧操纵室，四周装有有色玻璃，前窗和天窗配有雨刮器和清洗器。
- 操纵杆扶手一体化设计，控制面板按人机工程学设计。
- 上车操纵室可翻转20°，拓宽视野。
- 操纵室配置冷暖空调，营造舒适环境。
- Streamlined operator's cab, tinted panes all around, wiper and washer are equipped on both windshield and roof window.
- Armrest integrated with control levers, and control console designed ergonomically.
- It can be tilted back 20° for increased operator visibility during operation.
- Heater and air conditioner contribute to comfortable circumstance.

舒适的下车驾驶室

COMFORTABLE
DRIVER'S CAB

- 采用新型外观结构驾驶室，结构上采用气缸悬挂，降低车辆振动对驾驶人员的影响。
- 采用空气悬浮座椅，可多方位调整并配备安全带，提高驾乘舒适性。
- 电动后视镜、电动门窗提高操作的舒适性。
- 操作和显示元件的放置位置符合人机工程学原理，保证连续使用时操作的简便性和舒适性。
- 方向盘的高度和角度均可调。
- 反光镜可加热、并可电动调节。
- 3套自动清洗装置和间歇控制功能的雨刮器。
- New appearance driver's cab, and air cylinder suspension structure is used to reduce vibration effect to driver.
- Air cushioned seat is adjustable at multi-direction, with safety belt equipped, driving comfort is improved.
- Electric exterior mirrors, doors and windows improve the comfort of operation.
- Ergonomic location of operating elements and indicators ensures simplification and comfort during continuous operation.
- Steering wheel adjustable in height and inclination.
- Heatable and electrically adjustable exterior mirrors.
- Three sets of automatic washer and intermittent wiper are available.

QAY220 徐工集团全地面起重机

XCMG ALL TERRAIN CRANE



智能化操控系统

Intelligent control system

徐重专有控制系统

XCMG UNIQUE CONTROL SYSTEM

- 标准应用程序：力矩限制器功能、主显示画面程序、工况选择程序、性能浏览程序等。
- 方便的互动式工况设置。
- 工况的调整可以实时显示，直观、方便。
- 力矩过载或其它危险动作，控制程序自动进行限制。
- 精确的手柄调节功能，使操作平稳、高效。
- Standard application programs for: load moment indication function, main display, working condition selection and performance browse etc.
- Convenient interactive working condition setting.
- Real-time indication of adjustment for working condition, visual and convenient.
- Moment overloading and other dangerous movements may be limited automatically by control program.
- Accurate adjusting function of lever makes operation smooth and efficient.



辅助伸缩臂系统

TELESCOPING BOOM CONTROL SYSTEM

- 通过直观的显示界面实时检测伸缩过程。
- 可自由选择自动、手动伸缩模式，高效、便捷。
- 具有自动伸缩功能，操作简单。
- 可以方便进行参数的校正。
- The testing of boom telescoping process is indicated by visual display interface.
- Manual and automatic telescoping modes may be selected freely, high efficient and convenient.
- Automatic telescoping function is available, easy to operate.
- Parameters may be calibrated easily.

伸缩组合	重量	幅度	速度	代码
8.7	80t	000001		
	68t	000002		
	47t	000003		
	35t	000004		
	23t	000005		
	0t	000006		
6.5	80t	000011		
	68t	000012		
	47t	000013		
	35t	000014		
	23t	000015		
	0t	000016		

若伸缩组合为空，则代表适合该臂长的所有组合！
If Tele-com is empty, suitable for every Tele-com of this boom length !

注意： 该性能表仅供参考，实际的数据以厂家提供的为准！
Attention: The loadchart is just for your reference, Please use the actual data sheet offered by XZZX.



功能强大、高效的CAN总线技术
POWERFUL AND HIGH EFFICIENT CANBUS TECHNOLOGY

- 控制器之间采用总线连接，减少接口，提高了可靠性。
- 总线型元器件可由控制节点进行诊断，快速、准确的判断故障。
- 实时采集发动机数据并作出调整，提高整机性能。
- 标准的总线技术具有极大的扩展空间，并提高整机效率。
- CANbus is used between controllers, interface decrement improves reliability.
- CANbus components may be diagnosed by control nodes, fault may be judged quickly and accurately.
- Real-time collection of engine data and subsequent regulation improve whole machine performance.
- Standard CANbus technology has extensive space to improve entire machine efficiency.

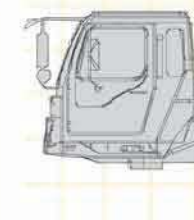

QAY220

徐工集团全地面起重机
XCMG ALL TERRAIN CRANE

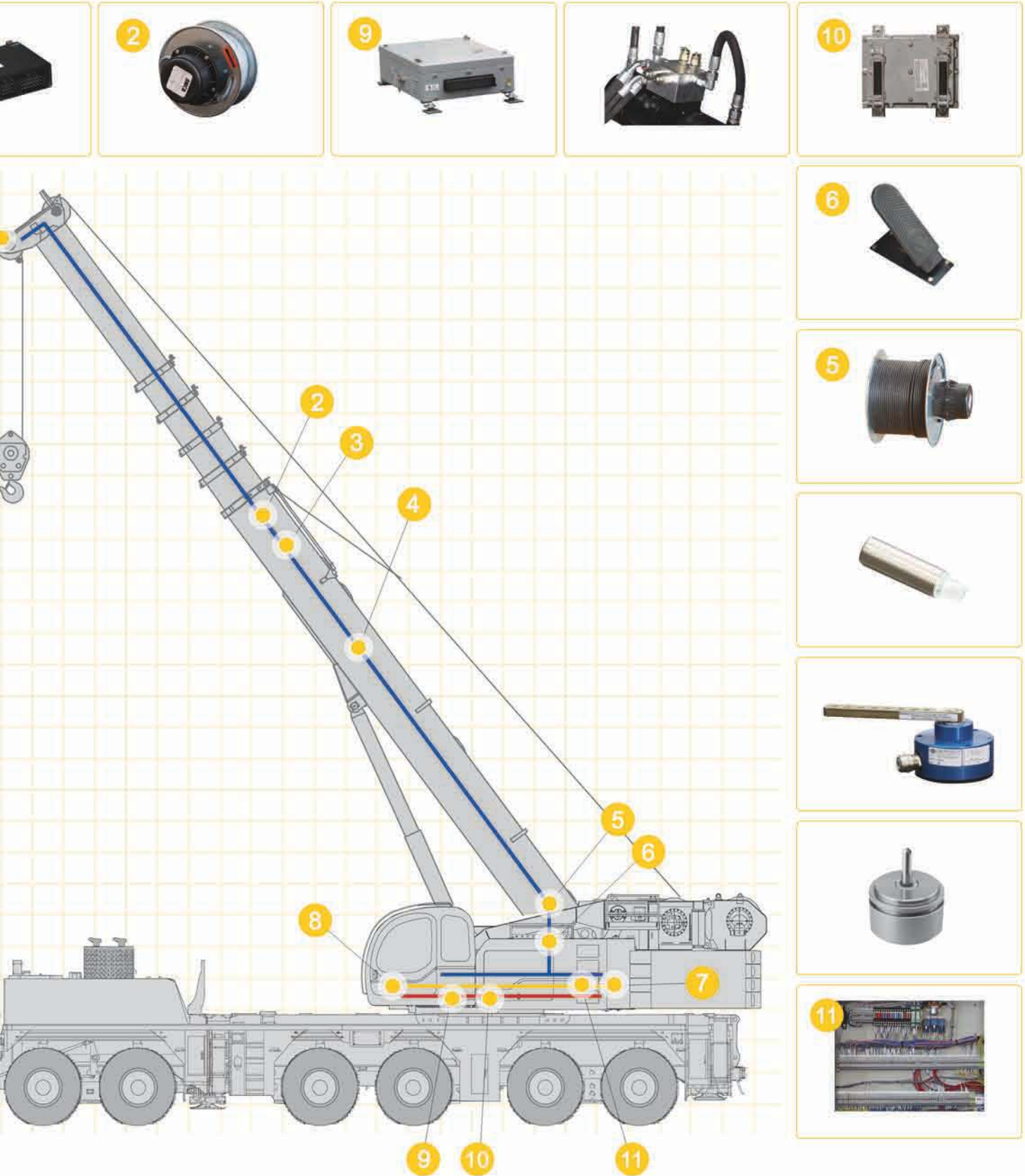

虚拟墙系统
VIRTUAL WALL SYSTEM

- 针对具体工作区域进行限制，方便、安全。
- 滑轮头的起升高度限制 ●工作半径限制 ●回转角度限制 ●边界限制
- Convenient and safe, it is aimed to limit
- The lifting height of pulley head ●Working radius ●Slewing angle ●Boundary

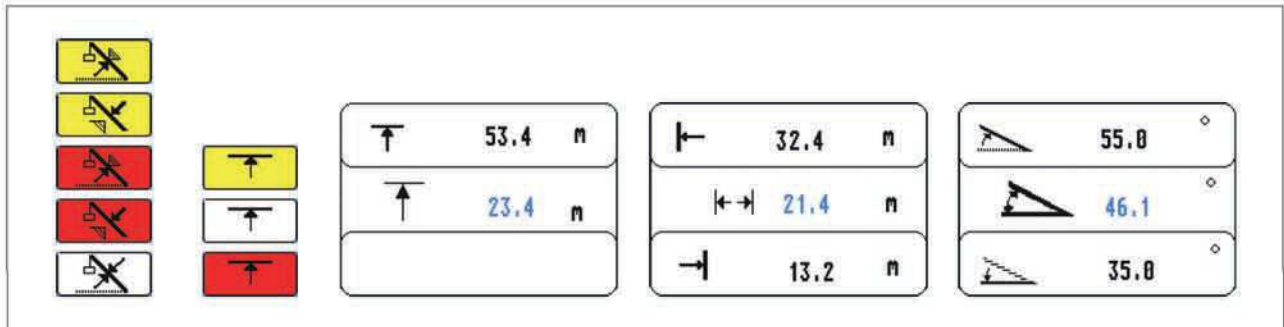

完善的故障诊断及实时检测功能
PERFECT FAULT DIAGNOSE AND REAL-TIME TESTING FUNCTION

- 维修人员可以方便快捷的通过自诊断系统寻找故障点，并由通过故障提示排除故障。
- 将操作过程直观的显示在界面上，用户可以方便的进行查询。
- 将各主要器件的参数直接显示，操作人员可以观察整个系统的输入及输出。
- Fault may be found quickly through the diagnose system, and be removed by indication.
- Operating process is indicated directly on the interface, and inquiry is able to be done.
- Parameters of main parts are displayed directly, and the input and output of whole system may be observed by operator.

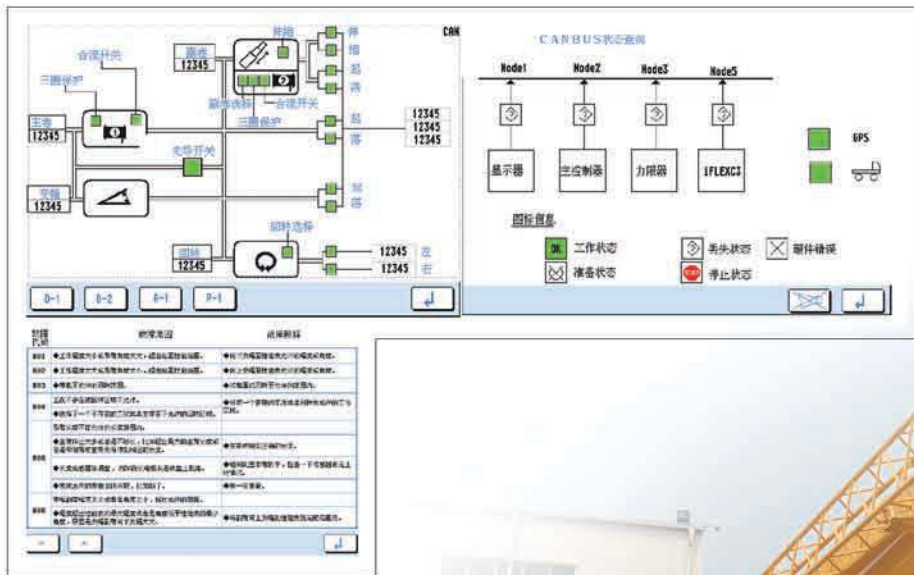

第二代王者时代

徐工**引爆**中国全地面起重机第二次技术革命

THE SECOND GENERATION KING'S TIME

XCMG IGNITES THE 2ND ALL TERRAIN CRANE REVOLUTION IN CHINA





QAY220 徐工集团全地面起重机

XCMG ALL TERRAIN CRANE



徐州重型机械有限公司
XUZHOU HEAVY MACHINERY CO.,LTD.

地址：中国江苏省徐州市铜山路165号

Add: No. 165, Tongshan Road, Xuzhou City, Jiangsu Province, China

销售电话(Sales Tel): 0086-0516-83462242 83462350

销售传真(Sales Fax): 0086-0516-83461669

邮编(Post Code): 221004

服务电话(Service Tel): 0086-0516-83461183

服务传真(Service Fax): 0086-0516-83461180

质量监督电话(Quality Inquiry Tel): 0086-0516-87888268

备件电话(Spare Parts Tel): 0086-0516-83461542