

Load Rating Chart

Model 22101S





© Manitex 2000

NOTE: Additional copies of this Load Rating Chart can be purchased from your Manitex Distributor. When ordering, use the part number shown in the bottom left corner of this page.

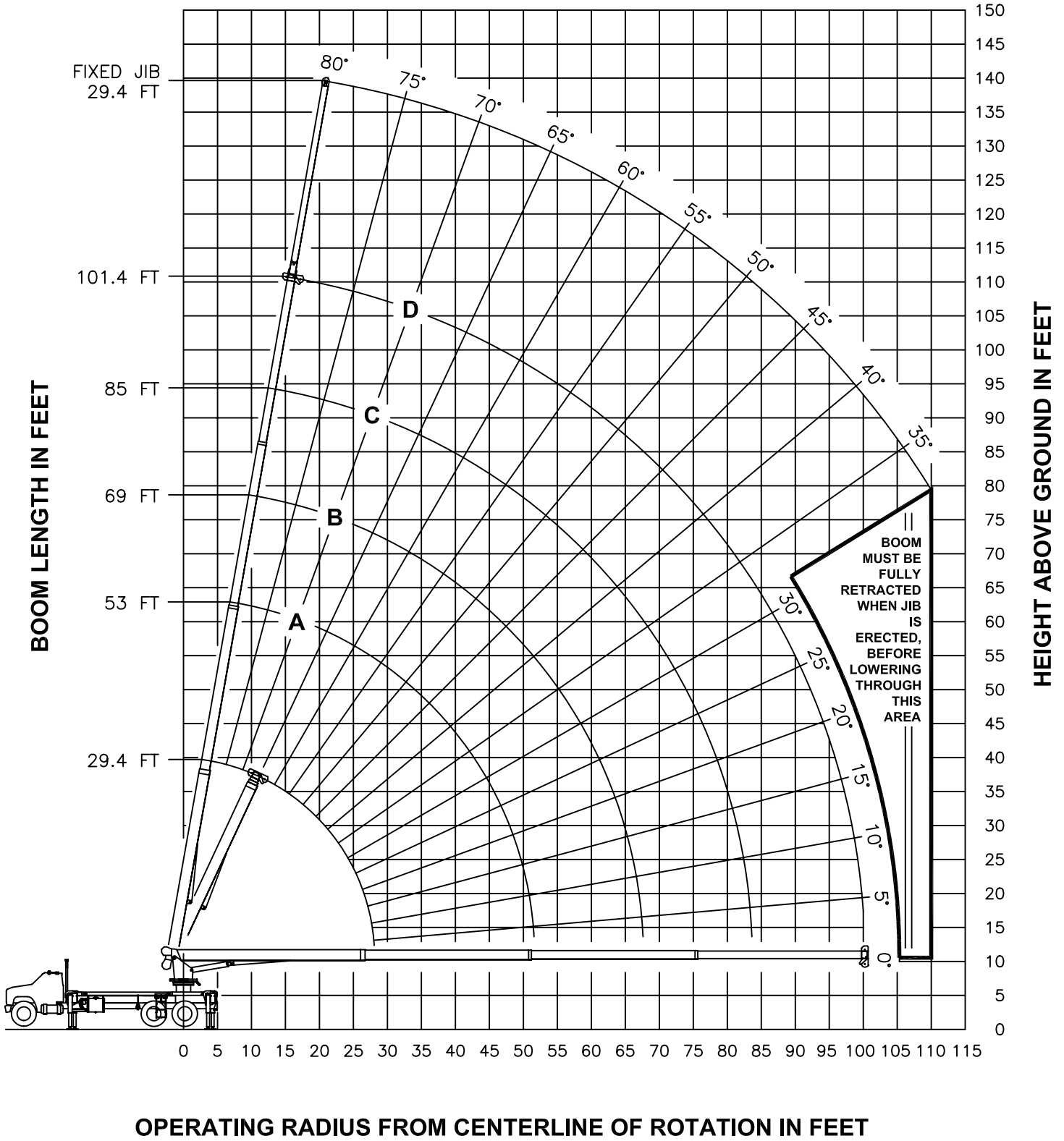
RANGE DIAGRAM - FULLY EXTENDED OUTRIGGER CONFIGURATION -

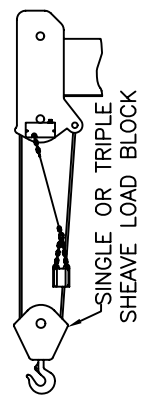
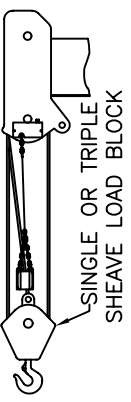
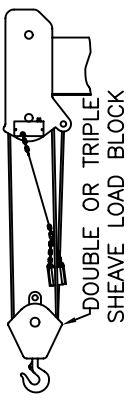

ALLOWABLE LINE PULL						WARNING
1 PART LINE	2 PART LINE	3 PART LINE	4 PART LINE	5 PART LINE	6 PART LINE	
						<p>ANTI-TWO-BLOCK SYSTEM MUST BE IN GOOD OPERATING CONDITION BEFORE OPERATING CRANE. REFER TO OWNER'S MANUAL.</p> <p>KEEP AT LEAST 3 WRAPS OF LOAD LINE ON DRUM AT ALL TIMES.</p>
8500 LBS	17000 LBS	25500 LBS	34000 LBS	42500 LBS	44000 LBS	
7400 LBS	14800 LBS	22200 LBS	29600 LBS	37000 LBS	44000 LBS	
						<p>9/16" - 6X25 IWRC (3.5:1 S.F.) 29750 LBS. BREAKING STRENGTH</p> <p>9/16" ROT RESISTANT (5.0:1 S.F.) 37000 LBS. BREAKING STRENGTH</p>

AREA OF OPERATION

WARNING:

THE FRONT TIRES MUST BE IN CONTACT WITH THE GROUND, AND THE MACHINE LEVEL, WHEN OPERATING IN THIS AREA.

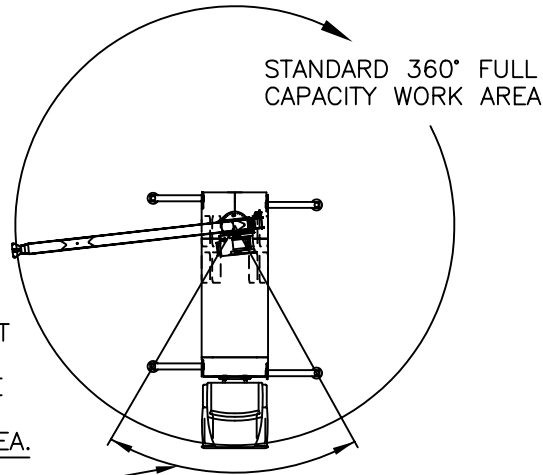

DEDUCTIONS FROM RATED LOADS FOR LOAD HANDLING DEVICES SUPPLIED BY MANITEX

AUXILIARY BLOCK — — — — — 50 LBS
 OVERHAUL BALL — — — — — SEE OVERHAUL BALL MANUFACTURER NAMEPLATE
 LOAD BLOCK — — — — — SEE BLOCK MANUFACTURER NAMEPLATE
 HOSE REEL — — — — — 160 LBS
 SWING AROUND JIB — — — — — SEE LOAD CHART

**USE THIS CHART
ONLY WHEN ALL
OUTRIGGERS ARE
FULLY RETRACTED**

PINS MUST BE
DISENGAGED FOR
THIS OUTRIGGER
CONFIGURATION

ALL OUTRIGGER
BEAMS FULLY
RETRACTED

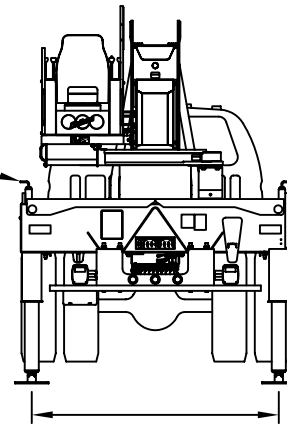

88.38 REF
(7' 4-3/8" REF)

- FULLY RETRACTED OUTRIGGER CONFIGURATION -

MAIN BOOM LOAD RATINGS IN LBS												
LMI CODE #13												
OPERATING RADIUS FT	LOADED BOOM ANGLE		BOOM LENGTH AND MARKER									
	°	FT	°	FT	A		B		C		D	
					°	FT	°	FT	°	FT	°	FT
5	80	44000										
8	74	19630										
10	70	12510										
12	66	8810	78	9270								
14	61	6540	76	6970	80	7090						
17	54	4420	72	4830	78	4940						
20	46	3060	69	3470	75	3580	79	3640				
25	29	1640	63	2050	71	2160	75	2220	79	2260		
30			56	1170	66	1270	72	1330	76	1370		
35					61	670	68	730	73	770		
340 LBS.			190 LBS.		150 LBS.		120 LBS.		100 LBS.		DEDUCTIONS FOR STOWED JIB	

**NO JIBS ARE TO
BE ERECTED IN
THIS
OUTRIGGER
CONFIGURATION**

RANGE DIAGRAM - FULLY RETRACTED OUTRIGGER CONFIGURATION -

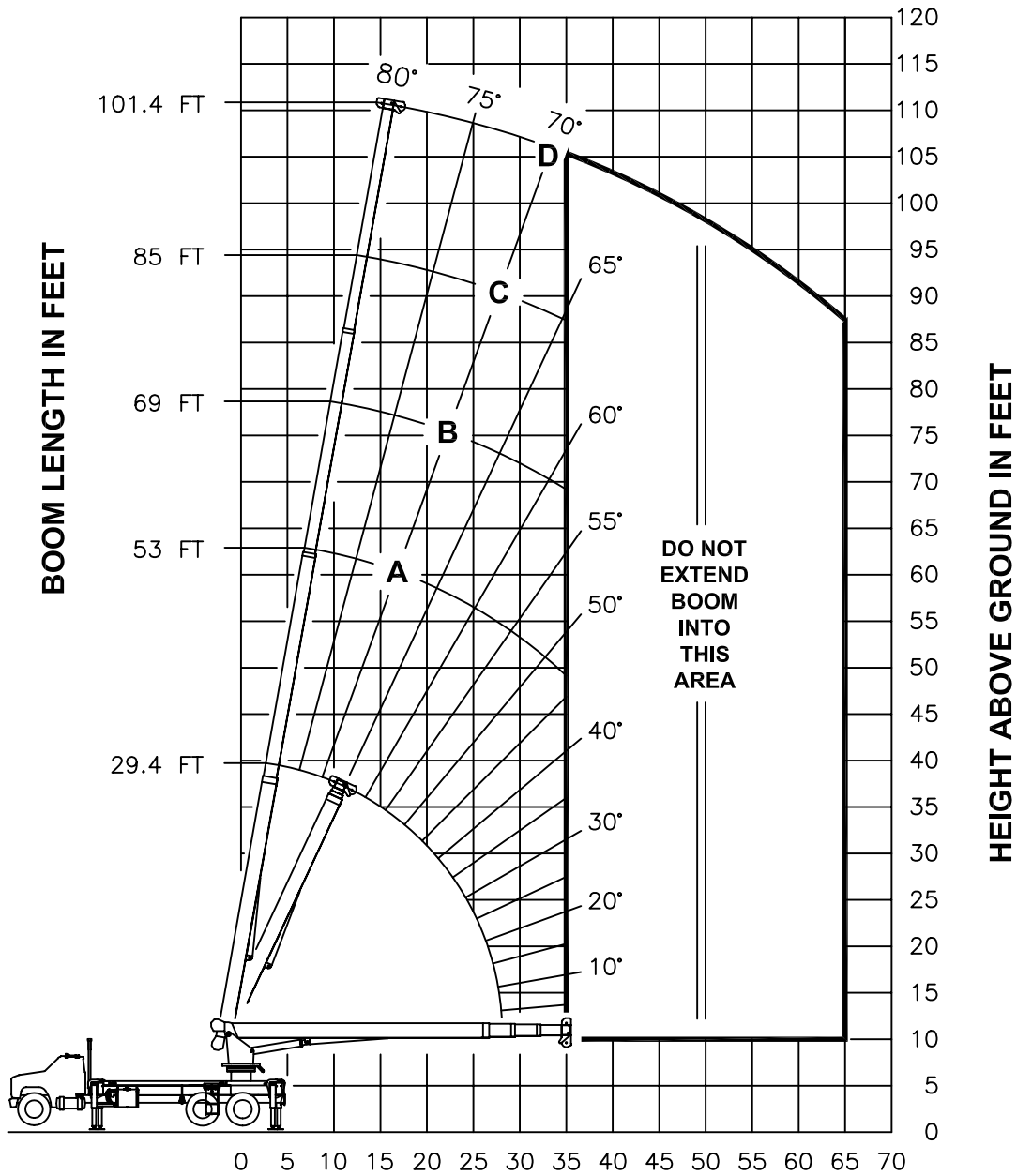

OPERATING RADIUS FROM CENTERLINE OF ROTATION IN FEET

NOTE : LIFTING PERSONNEL WITH CRANE IN THIS OUTRIGGER CONFIGURATION IS STRICTLY PROHIBITED. USE ONLY FULLY EXTENDED OUTRIGGER CONFIGURATION WHEN LIFTING PERSONNEL.

**USE THIS CHART ONLY
WHEN ALL
OUTRIGGERS ARE IN
THE INTERMEDIATE
POSITION**

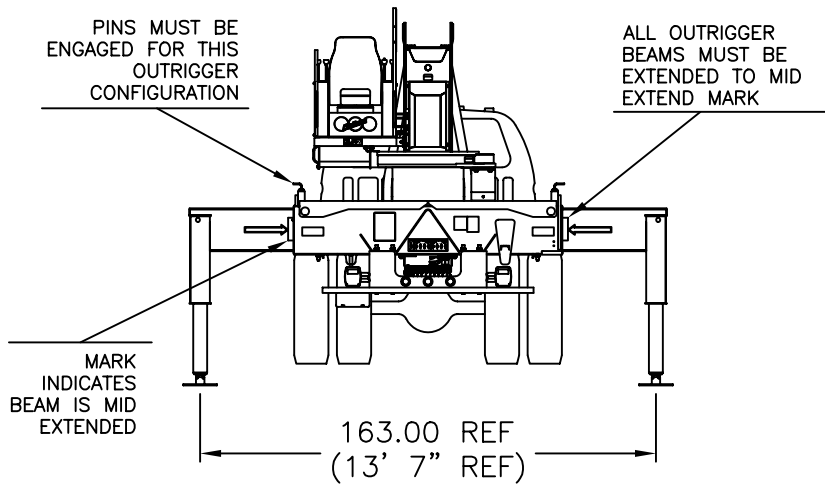

**- INTERMEDIATE OUTRIGGER CONFIGURATION -
(MID EXTEND)**

MAIN BOOM LOAD RATINGS IN LBS										JIB LOAD RATINGS IN LBS			
LMI CODE #9										LMI CODE #10			
OPERATING RADIUS FT	LOADED BOOM ANGLE BOOM LENGTH AND MARKER									OPERATING RADIUS FT	BOOM ANGLE LOADED	29.4 FT JIB FOR ALL BOOM LENGTHS SEE WARNING NOTE 4	
	∠	29.4 FT	∠	A	∠	B	∠	C	∠				D
	∠	29.4 FT	∠	53 FT	∠	69 FT	∠	85 FT	∠	101.4 FT		∠	RATED LOAD IN POUNDS
5	80	44000											
8	74	33540										8	
10	70	28140										10	
12	66	24230	78	14000								12	
14	61	20460	76	14000	80	14000						14	
17	54	14040	72	14000	78	12880						17	
20	46	10190	69	10690	75	10820	79	8920				20	
25	29	6560	63	7050	71	7170	75	7240	79	6000		25	
30			56	4970	66	5090	72	5160	76	5210	30	80	3000
35			49	3630	61	3750	68	3810	73	3860	35	78	2840
40			41	2690	56	2810	65	2870	70	2910	40	76	2620
45			31	1990	51	2110	61	2180	67	2220	45	73	2310
50			17	1450	45	1570	57	1640	64	1680	50	71	1770
55					38	1150	52	1220	61	1260	55	69	1350
60					30	800	47	870	57	910	60	67	1000
65											65	64	710
70											70	62	470
			340 LBS.	190 LBS.	150 LBS.	120 LBS.	100 LBS.	DEDUCTIONS FOR STOWED JIB					

RANGE DIAGRAM - INTERMEDIATE OUTRIGGER CONFIGURATION - (MID EXTEND)

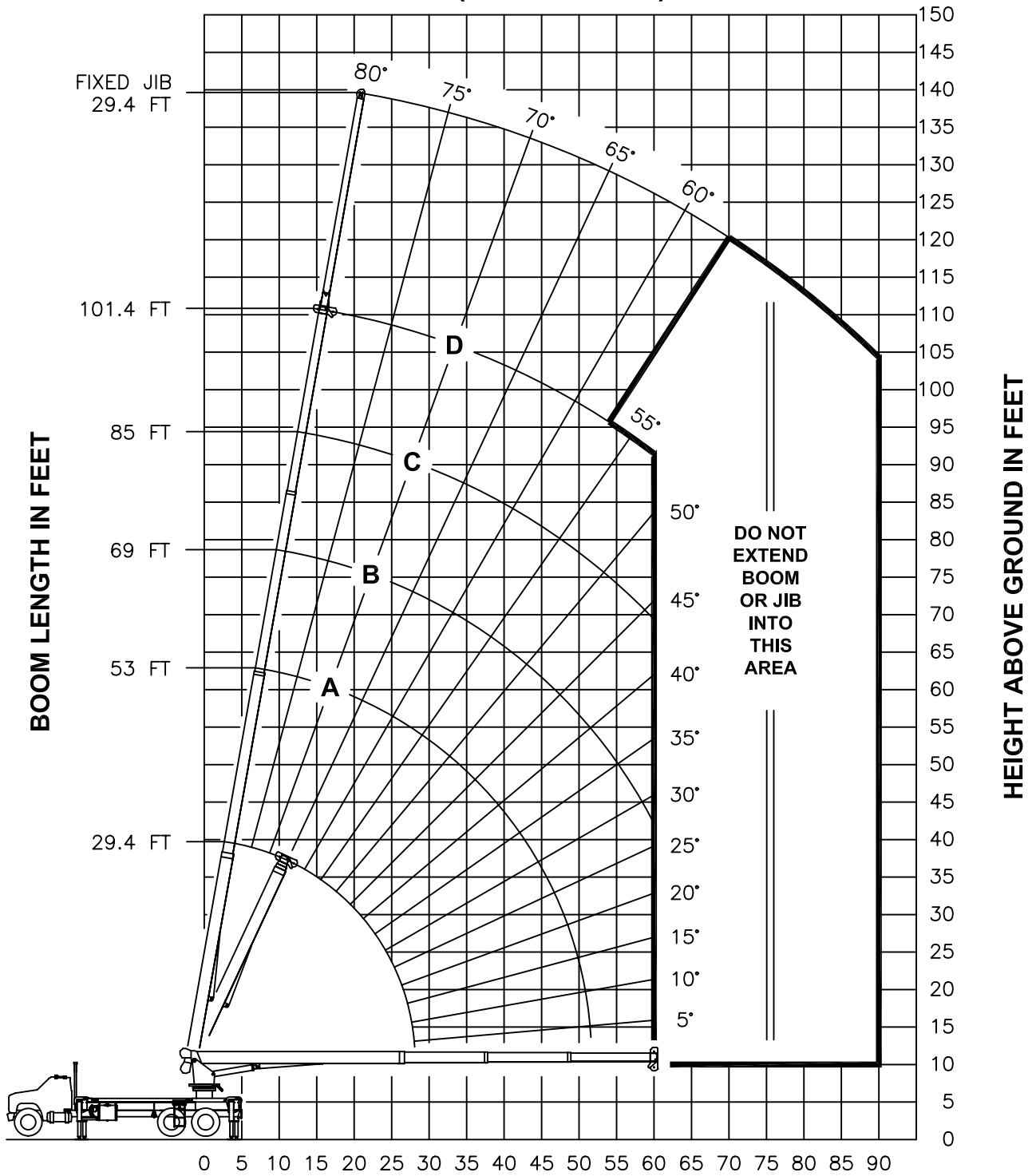

OPERATING RADIUS FROM CENTERLINE OF ROTATION IN FEET

NOTE : LIFTING PERSONNEL WITH CRANE IN THIS OUTRIGGER CONFIGURATION IS STRICTLY PROHIBITED. USE ONLY FULLY EXTENDED OUTRIGGER CONFIGURATION WHEN LIFTING PERSONNEL.

**USE THIS CHART ONLY
WHEN ALL
OUTRIGGERS ARE
FULLY EXTENDED**

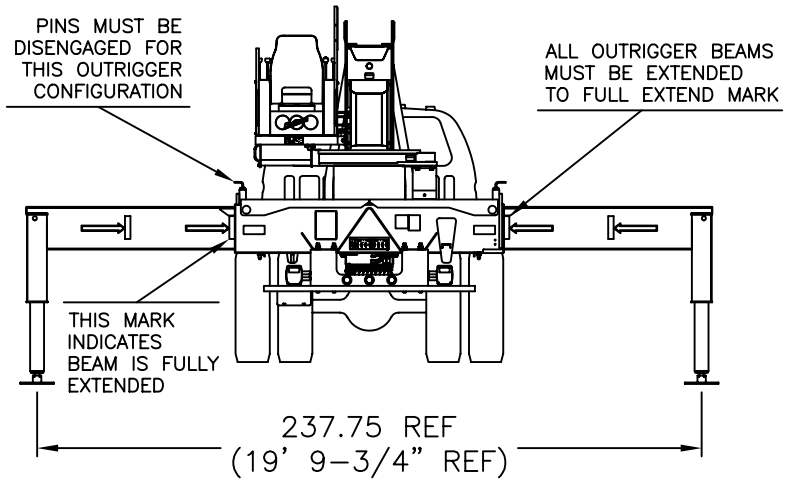

- FULLY EXTENDED OUTRIGGER CONFIGURATION -

MAIN BOOM LOAD RATINGS IN LBS										JIB LOAD RATINGS IN LBS			
LMI CODE #1										LMI CODE #2			
OPERATING RADIUS FT	LOADED BOOM ANGLE		BOOM LENGTH AND MARKER								OPERATING RADIUS FT	BOOM ANGLE	29.4 FT JIB FOR ALL BOOM LENGTHS SEE WARNING NOTE 4
	∠	29.4 FT	∠	A	∠	B	∠	C	∠	D			
			53 FT		69 FT		85 FT		101.4 FT				
5	80	44000											
8	74	33540									8		
10	70	28140									10		
12	66	24230	78	14000							12		
14	61	20460	76	14000	80	14000					14		
17	54	16400	72	14000	78	12880					17		
20	46	13520	69	13700	75	11430	79	8920			20		
25	29	10210	63	10600	71	9460	75	8000	79	6000	25		
30			56	8390	66	8210	72	7070	76	5500	30	80	3000
35			49	6790	61	6890	68	6130	73	4980	35	78	2840
40			41	5590	56	5700	65	5320	70	4490	40	76	2620
45			31	4640	51	4760	61	4640	67	4000	45	73	2420
50			17	3880	45	4000	57	4070	64	3580	50	71	2230
55					38	3380	52	3450	61	3200	55	69	2020
60					30	2860	47	2930	57	2850	60	67	1840
65					19	2410	42	2490	54	2520	65	64	1670
70							36	2090	50	2130	70	62	1520
75							29	1740	45	1790	75	59	1380
80							20	1440	41	1500	80	56	1230
85									36	1240	85	53	1080
90									30	1020	90	50	950
95									22	820	95	47	830
100											100	44	720
105											105	40	570
110											110	36	430
		340 LBS.		190 LBS.		150 LBS.		120 LBS.		100 LBS.	DEDUCTIONS FOR STOWED JIB		

LMI OPERATING CODES

SETTING	CRANE CONFIGURATION	OUTRIGGER CONFIGURATION
#1	— MAIN BOOM	FULLY EXTENDED
#2	— FIXED JIB	FULLY EXTENDED
#5	— PERSONNEL LIFTING PLATFORM ON MAIN BOOM	FULLY EXTENDED
#6	— PERSONNEL LIFTING PLATFORM ON FIXED JIB	FULLY EXTENDED
#9	— MAIN BOOM	INTERMEDIATE
#10	— FIXED JIB	INTERMEDIATE
#13	— MAIN BOOM	FULLY RETRACTED

WARNING

1. THE OPERATOR MUST READ AND UNDERSTAND THE OWNER'S MANUAL BEFORE OPERATING THIS CRANE.
2. POSITIONING OR OPERATION OF CRANE BEYOND AREAS SHOWN ON THIS CHART IS NOT INTENDED OR APPROVED EXCEPT WHERE SPECIFIED IN OWNER'S MANUAL.
3. LOADED BOOM ANGLES AT SPECIFIED BOOM LENGTHS GIVE ONLY AN APPROXIMATION OF THE OPERATING RADIUS. THE BOOM ANGLE BEFORE LOADING SHOULD BE GREATER TO ACCOUNT FOR DEFLECTIONS. DO NOT EXCEED THE OPERATING RADIUS FOR RATED LOADS.
4. THE OPERATING RADIUS SHOWN IN THE JIB RATING CHART IS FOR FULLY EXTENDED BOOM ONLY. WHEN BOOM IS NOT FULLY EXTENDED, USE ONLY LOADED BOOM ANGLE TO DETERMINE LOAD RATING OF JIB.
5. FOR BOOM ANGLES NOT SHOWN ON JIB LOAD RATING CHART, USE RATING OF NEXT LOWER BOOM ANGLE.
6. FOR BOOM LENGTHS NOT SHOWN, USE RATING OF NEXT SHORTER OR LONGER BOOM LENGTH, WHICHEVER IS LESS. FOR RADII NOT SHOWN, USE RATING OF NEXT LONGER RADIUS.
7. CRANE LOAD RATINGS ON OUTRIGGERS ARE BASED ON FREELY SUSPENDED LOADS WITH THE MACHINE LEVELED AND STANDING ON A FIRM UNIFORM SUPPORTING SURFACE. NO ATTEMPT SHALL BE MADE TO MOVE A LOAD HORIZONTALLY ON THE GROUND IN ANY DIRECTION.

WARNING (CONTINUED)

8. PRACTICAL WORKING LOADS DEPEND ON SUPPORTING SURFACE, WIND, AND OTHER FACTORS AFFECTING STABILITY SUCH AS HAZARDOUS SURROUNDINGS, EXPERIENCE OF PERSONNEL, AND PROPER HANDLING, ALL OF WHICH MUST BE TAKEN INTO ACCOUNT BY THE OPERATOR.
9. THE MAXIMUM LOAD WHICH MAY BE TELESCOPED IS LIMITED BY HYDRAULIC PRESSURE, BOOM ANGLE, AND BOOM LUBRICATION. IT IS SAFE TO ATTEMPT TO TELESCOPE ANY LOAD WITHIN THE LIMITS OF THE LOAD RATING CHART. BOOM MUST BE FULLY RETRACTED AGAINST BOOM STOPS AT ALL TIMES WHEN LIFTING MINIMUM BOOM LENGTH CAPACITY LOADS.
10. LIFTING OFF THE MAIN BOOM POINT WHILE THE SWING AROUND JIB IS ERECTED IS NOT INTENDED OR APPROVED.

INFORMATION

1. DEDUCTIONS MUST BE MADE FROM RATED LOADS FOR STOWED JIB, OPTIONAL ATTACHMENTS, HOOKS, AND LOADBLOCKS (SEE DEDUCTION CHART). WEIGHTS OF SLINGS AND ALL OTHER LOAD HANDLING DEVICES SHALL BE CONSIDERED A PART OF THE LOAD.
2. LOAD RATINGS ABOVE THE HEAVY LINE ARE STRUCTURALLY LIMITED CAPACITIES. LOAD RATINGS BELOW THE HEAVY LINE ARE STABILITY LIMITED CAPACITIES AND DO NOT EXCEED 85% OF TIPPING.

DEFINITIONS

1. OPERATING RADIUS IS THE HORIZONTAL DISTANCE FROM THE AXIS OF ROTATION TO THE CENTER OF THE VERTICAL HOIST LINE OR TACKLE WITH LOAD APPLIED.
2. LOADED BOOM ANGLE AS SHOWN IN THE COLUMN HEADED BY , IS THE INCLUDED ANGLE BETWEEN THE HORIZONTAL AND LONGITUDINAL AXES OF THE BOOM BASE AFTER LIFTING RATED LOAD AT RATED RADIUS.