

# Specifications

Hydraulic Truck Crane

GENERAL INFORMATION ONLY

## HTC-1170 70-ton (63.55 metric ton)

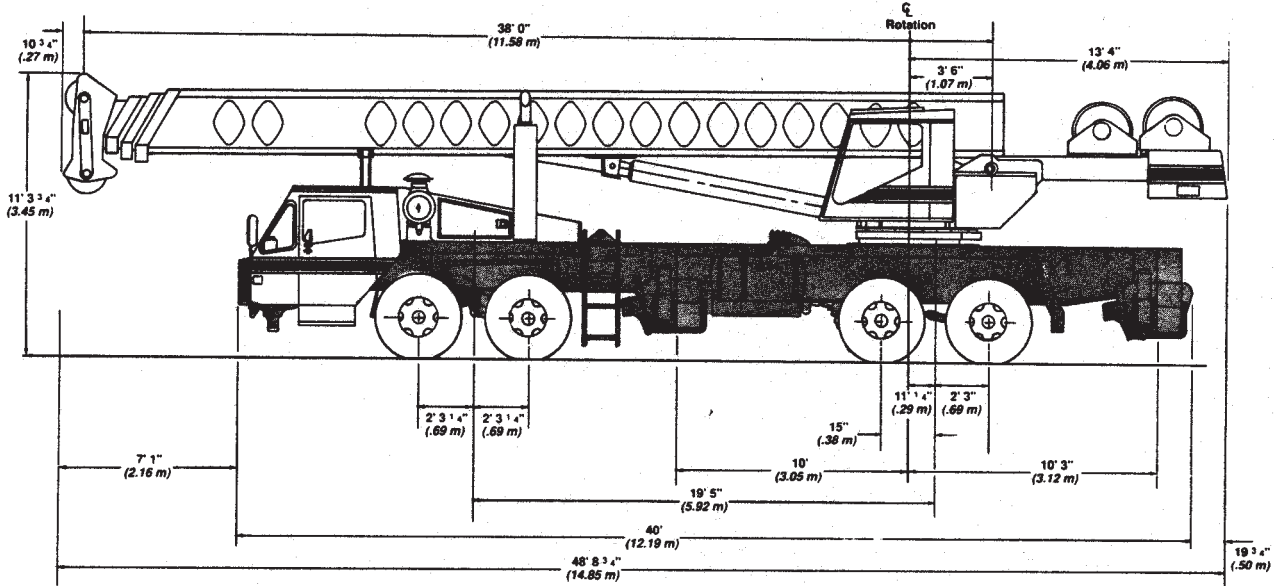

Not to Scale

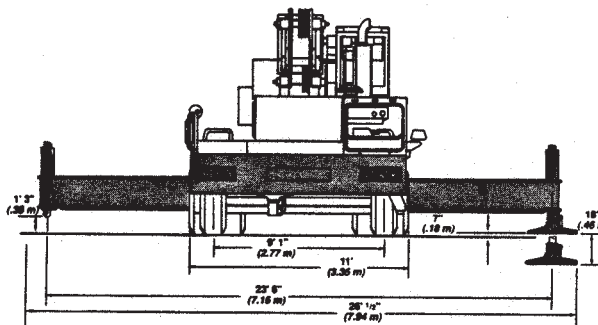

Not to Scale

General dimensions	feet	meters
Tailswing across corners	13' 7-3/16"	4.14
Ground clearance - Standard Tires	9"	.23
Ground clearance - Optional Tires	10-1/2"	.27
Turning radius C/L of tire	44' 0"	13.41
Turning radius - wall to wall	50' 0"	15.24

## Level speeds and gradeability

Engine	Maximum Speed		* Maximum Gradeability at Peak Engine Torque	
	mph	km/h	Manual	Automatic
Cummins NTA-C310	48.1	77.39	31.71%	--
Cummins NTA-C400	48.1	77.39	37.84%	51.89%
Cummins N14-330	52.6	84.63	49.58%	--
Cummins N14-410	52.6	84.63	53.11%	--

GENERAL INFORMATION ONLY

\* Low gear, high range

## Engine specifications

Engine	Cummins NTA-C310	Cummins NTA-C400 *	Cummins N14-330 *	Cummins N14-410 *
Cylinders -- cycle	6 -- 4	6 -- 4	6 -- 4	6 -- 4
Bore	5.5" (140 mm)	5.5" (140 mm)	5.5" (140 mm)	5.5" (140 mm)
Stroke	6.0" (152 mm)	6.0" (152 mm)	6.0" (152 mm)	6.0" (152 mm)
Displacement	855 cu. in. (14 013 cm <sup>3</sup> )	855 cu. in. (14 013 cm <sup>3</sup> )	855 cu. in. (14 013 cm <sup>3</sup> )	855 cu. in. (14 013 cm <sup>3</sup> )
Gross engine power	310 hp @ 2,100 rpm	400 hp @ 2,100 rpm	330 hp @ 1,950 rpm	410 hp @ 1,950 rpm
Peak torque	1,005 ft. lbs. (1 363 J) @ 1,400 rpm	1,200 ft. lbs. (1 627 J) @ 1,400 rpm	1,350 ft. lbs. (1 831 J) @ 1,100 rpm	1,450 ft. lbs. (1 966 J) @ 1,200 rpm
Electric system	12 volt	12 volt	12 volt	12 volt
Fuel capacity	100 gallons (378.54 L)	100 gallons (378.54 L)	100 gallons (378.54 L)	100 gallons (378.54 L)
Alternator	80 amps	80 amps	90 amps	90 amps
Crankcase capacity	11.0 gallons (41.64 L)	11.0 gallons (41.64 L)	11.0 gallons (41.64 L)	11.0 gallons (41.64 L)
Air compressor	13.2 c.f.m. (.37 m <sup>3</sup> /min)	13.2 c.f.m. (.37 m <sup>3</sup> /min)	13.2 c.f.m. (.37 m <sup>3</sup> /min)	13.2 c.f.m. (.37 m <sup>3</sup> /min)
Block water heater	115 volts, 1,500 watts	115 volts, 1,500 watts	115 volts, 1,500 watts	115 volts, 1,500 watts

\* Optional

## Axle loads<sup>①</sup>

Base machine with 38' 0" - 120' 6" (11.58-36.73 m) 4-section boom, 35' (10.76 m) offsettable lattice fly, load moment indicator, main winch with two-speed hoisting and power up/down, 600' (182.88m) 3/4" (19mm) wire rope, Link-Belt 8x4 11' (3.35 m) wide carrier with front bumper outrigger, Cummins NTA-C310 diesel engine, Roadranger transmission, full fuel and hydraulic oil, and counterweight.	G.V.W.		Upper facing front				Upper facing rear			
	lbs.	kgs	Front axle		Rear axle		Front axle		Rear axle	
			lbs.	kgs	lbs.	kgs	lbs.	kgs	lbs.	kgs
	96,880	43 944	34,724	15 750	62,156	28 194	13,423	6 088	83,457	37 856
<b>Add</b>										
Cummins NTA-C400 engine	60	28	69	32	-9	-4	69	32	-9	-4
Cummins N14-330 or N14-410 with charge air cooler	168	76	171	78	-4	-2	171	78	-4	-2
Automatic transmission	150	68	103	47	47	21	103	47	47	21
Hookblock at boom head	975	442	1,779	807	-804	-365	-1,685	-764	2,660	1 206
Headache ball at boom head	325	147	603	273	-278	-126	-572	-259	897	406
Auxiliary lifting sheave	182	83	351	159	-169	-77	-333	-151	515	233
35' - 61' offsettable telescoping fly	965	438	850	386	115	52	-756	-343	1,721	780
Counterweight removal system	122	55	-68	-31	190	86	80	36	42	19
Aluminum fenders	-350	-159	-129	-59	-221	-100	-129	-59	-221	-100
Free fall - main winch (1 drum)	442	200	-194	-88	636	288	237	107	205	93
2 winches - free fall rear only (2 drums)	382	173	-181	-82	564	256	218	99	165	75
Free fall - main/auxiliary winch	824	374	-312	-142	1,136	515	392	178	432	196
<b>Remove</b>										
Counterweight, one or two winches	-9,050	-4 105	5,074	2 302	-14,124	-6 407	-5,948	-2 698	-3,102	-1 407
Lattice fly	-1,605	-728	-1,315	-596	-290	-132	-1,160	-526	2,765	1 254
35' - 61' offsettable telescoping fly	-2,750	-1 247	-2,165	-982	-405	-183	-1,916	-869	4,486	2 035

① All weights are ± 3%

©Link-Belt is a registered trademark. Copyright © 1991.

We are constantly improving our products and therefore reserve the right to change designs and specifications.

**Link-Belt Construction Equipment Company Lexington, Kentucky**

A unit of Sumitomo Construction Machinery Co., Ltd.