

# P&H<sup>®</sup> ΩMEGA<sup>®</sup> T-400

**40-ton hydraulic truck crane  
170-ft. (51.8 m) maximum tip height**



**PROVEN ΩMEGA<sup>®</sup> UPPER WITH NEW TRUCK CARRIER**

- **Excellent reach** afforded by telescoping 106 ft. (32.3 m) 3-section boom with power-pinned manual 4th section. Add 34 ft. (10.4 m) lattice boom extension and 25 ft. (7.6 m) jib for total length of 165 ft. (50.3 m)
- **Telescope rated loads** for precise placement. Semi-fixed cylinder mounts decrease cylinder deflection under load and increase telescoping capacity.
- **Superior lifting performance** provided by rectangular, full depth four-plate boom that is welded inside and out.
- **New 8 x 4 truck carrier** has strong rigid frame utilizing a high strength rectangular box side rail construction, roomy lowline cab, sprung front suspension, 9'-9½" (3.0 m) road width and road speeds to 48.7 mph (78.4 Km/h).
- **Fast, solid set-up** with P&H scissors type outriggers. Excellent stability with 22'-8¾" (6.92 m) outrigger stance.
- **Turbocharged engine** offers low sound levels, low fuel consumption, excellent high altitude performance and superior torque for optimum horsepower usage.
- **Total operator comfort** means less fatigue and greater production. Spacious cab module allows placement of controls "in the palm of your hand", lots of leg and elbow room, and full vision of all activities.
- **A duty-cycle machine** — powerful P&H winches offer high line speeds, pull and controlled free fall. VOLUMATIK<sup>®</sup> hydraulic system provides optimum oil flow for fast crane functioning.
- **Less downtime** — T-400 is "Pit-Stop" maintenance-proven. It's industry's most serviceable crane — engineered for parts commonality, accessibility and fast tear-down.

## Specifications

# specifications



**BOOM:** All boom sections are of full depth rectangular four-plate construction welded inside and out, with adjustable nylon slider pads on top, bottom and sides. All powered sections are selectively sequenced, each section lever controlled. Boom point contains four 18.125" (460 mm) P.D. main sheaves and one 14.125" (359 mm) P.D. idler sheave. Sheaves are non-metallic with roller bearings. A fifth sheave to meet export code is optional. Semi-fixed telescope cylinder mounts provide capacity to telescope full rated loads.

Four (4) section boom, with manual section, 32.5' (9.9 m) retracted length, 106' (32.3 m) extended length, consisting of one base section, 2 powered sections and one manually pinned section with boom point which can be hydraulically extended or retracted (standard).

**BOOM EXTENSION (OPTIONAL):** For extending reach of boom, 34' (10.4 m) swing-around tapered lattice structure with single 18.125" (460 mm) P.D. non-metallic boom point sheave with roller bearing. Easily installed from ground level by pivoting from its stored position on right side of boom base and pin connecting to boom point.

**JIB (OPTIONAL):** For extending reach of boom extension, 25' (7.6 m) A-frame structure with single 14.125" (359 mm) P.D. non-metallic jib point sheave with bronze bushing, compression strut and guy cables. Pin and guy line connected.

**AUXILIARY SHEAVE (OPTIONAL):** Single non-metallic sheave 14.125" (359 mm) P.D. with bronze bushing, bracket-mounted on boom point, for use with single auxiliary winch line.

**HOOK BLOCKS (OPTIONAL):**

- A) 40 Ton — 4 sheaves with swivel hook and safety latch, for 3/4" (19 mm) wire rope.
- B) 20 Ton — 1 sheave with swivel hook and safety latch, for 3/4" (19 mm) wire rope
- C) 8.5 Ton — weighted hook with swivel and safety latch, for 3/4" (19 mm) wire rope.

## UPPER STRUCTURE



**OPERATOR'S CAB:** All-weather environmental cab of steel has hinged ceiling window, slide-by right side window with guard, large windows with full view in all directions and locking slide-by door. Safety glass used throughout. Operator's four-way adjustable seat has torsion suspension. Cab is 34.5 inches (876 mm) wide with a stand-up height of 56 inches (1422 mm) and is cushion-mounted for vibration dampening and noise reduction.

**CAB ACCESSORIES (STANDARD):** Cab contains all crane function controls in addition to mechanical boom angle indicator, electric windshield wiper, dash light, warning light and buzzer (monitoring hydraulic oil temperature, engine water temperature, air pressure and engine oil pressure), low voltage indicating light, fuel gauge, master ignition switch, engine start button, engine stop button, two-speed controls for winches, circular level, hand throttle, electric remote control of outriggers and cigarette lighter.

**CAB ACCESSORIES (OPTIONAL):** Heater (diesel or propane fueled, thermostatically controlled), defroster fan, electric roof window wiper windshield washer, seat belt, fire extinguisher, electronic boom angle indicator, electronic boom length indicator, load movement device, drum rotation indicators for main and auxiliary winches, vandal-proof glass (lexan), electronic anti-two-block device, cold weather engine starting aid, floodlights, rear view mirrors, electric horn and rotary roof beacon.



**CONTROLS:** In front of operator are foot pedals for boom hoist, swing brake and engine throttle. Mounted on left hand side of front console are three (3) double-acting levers for swing (with horn button) and telescope (2 telescope levers for individual positioning of powered sections of boom.) At the right are levers for auxiliary winch (optional), main winch, and boom hoist. On right side of seat are floor mounted levers for house lock and swing holding brake. Drum rotation indicators (optional) are mounted on auxiliary and main winch levers. At operator's right are console mounted switches for ignition, windshield wiper, defroster (optional), and outrigger controls. Also on console are engine start button, high temperature warning light, engine stop button, dash light, fuel gauge, air pressure gauge, circular level, and positive (air) hand throttle. Console is prewired removable module for ease of service.



**MAIN WINCH:** P&H Model 16 two-speed, mounted on revolving frame. Planetary gearing for power raising and lowering. Infinitely variable controlled speed. Spring applied, hydraulically released load holding caliper disc brake with controlled free-fall. Complete with 550' (167.6 m) wire rope.

Drum: Grooved 15" (381 mm) P.D. x 20" (508 mm) wide.

Wire Rope: 3/4" (19 mm) dia. 8 x 19 spin resistant, extra improved plow steel with 7 x 7 I.W.R.C.

Drum Capacity: 765 ft. (233 m) 6 layers.

Line Pull (Max.): 18,000 lb. (8165 kg) 1st layer.

Line Pull (Permissible): 10,000 lb. (4536 kg) per part of line.  
14,800 lb. (6713 kg) based on strength of recommended wire rope.

Line Speed (Max.): 543 fpm (166 m/m) 6th layer.

**AUXILIARY WINCH (OPTIONAL):** Same as main winch, but with 550' (167.6 m) wire rope and additional boom point idler sheave.

**AUXILIARY WINCH (OPTIONAL):** P&H Model 10-1 single-speed, mounted on counterweight. Planetary gearing for power raising and lowering. Infinitely variable controlled speed. Spring applied, hydraulically released load holding caliper disc brake with controlled free-fall. Complete with 450' (137.2 m) wire rope and additional boom point idler sheave.

Drum: Grooved 11.25" (286 mm) P.D. x 14" (356 mm) wide.

Wire Rope: 9/16" (14 mm) dia. 8 x 19 spin resistant, extra improved plow steel with 7 x 7 I.W.R.C.

Drum Capacity: 530 ft. (162 m) 6 layers.

Line Pull (Max.): 11,000 lb. (4990 kg) 1st layer.

Line Pull (Permissible): 7150 lb. (3243 kg) per part of line, 5th layer.  
8400 lb. (3810 kg) based on strength of recommended wire rope.

Line Speed (Max.): 459 fpm (140m/m) 6th layer.

**MAIN WINCH (EUROPEAN OPTION):** P&H Model 16 two-speed, mounted on revolving frame. Planetary gearing for power raising and lowering. Infinitely variable controlled speed. Spring applied, hydraulically released load holding caliper disc brake with controlled free-fall. Complete with wire rope.

Drum: Smooth 16" (406 mm) P.D. x 20" (508 mm) wide  
23.5" (597 mm) flange dia.

Wire Rope: (Europe) 16 mm Casar Special 8FK,  
220 Kg/mm<sup>2</sup> grade, 25.5 metric tons  
minimum breaking strength  
(Italy) 17 mm Casar Special 8FK,  
220 Kg/mm<sup>2</sup> grade, 28.15 metric tons  
minimum breaking strength

Drum Capacity: 16 mm — 608 ft. (185 m)  
17 mm — 519 ft. (158 m)

Four layers — 2 layers from flange edge.

Line Pull (Max.): 12,720 lb. (5770 kg) 1st layer

Line Pull (Permissible):

16 mm — 9370 lb. (4250 kg) with 6:1 S.F.  
17 mm — 9400 lb. (4265 kg) with 6.6:1 S.F.

Line Speed (Max.): 475 fpm (145 mpm) 4th layer.

**AUXILIARY WINCH (EUROPEAN OPTION):** Same as main winch, but with additional boom point idler sheave.

**SPECIAL MAIN & AUXILIARY WINCHES (EUROPEAN OPTION):** Same as standard, but with holding valve to eliminate controlled free fall.

**SHEAVE AND DRUM TO WIRE ROPE RATIOS: (Pitch Diameter)**

	Sheave to Wire Rope	Drum to Wire Rope
Boom Main Sheave	24.17 to 1	—
Boom Idler Sheave	18.83 to 1	—
Boom Ext. Sheave	24.17 to 1	—
Jib Sheave	18.83 to 1	—
Main Winch	—	20 to 1
Aux. Winch	—	20 to 1



**BOOM HOIST:** Two 8" (203 mm) I.D. cylinders, double-acting. Hydraulically powered raising and lowering with holding valve.

**BOOM TELESCOPE:** Two 6.0" (152 mm) I.D. cylinders — double-acting. Hydraulically powered raising and lowering with holding valve. Supplied by a single hose loop.

**VOLU-MATIK® HYDRAULIC SYSTEM:** This system utilizes 6 pumps and is designed to provide ample volume and pressure for optimum performance.

The right hand main tandem gear pump, at 2600 rpm (engine full load), provides 37 gpm (140 lpm) to the main and/or auxiliary winch boost circuits and 27 gpm (102.2 lpm) to the swing or outrigger circuits.

The left hand main tandem gear pump, at 2600 rpm (engine full load) provides 51 gpm (193 lpm) to the main and/or auxiliary winch circuits and 51 gpm (193 lpm) to the boom hoist and telescope circuits.

The fifth pump, driven at 2600 rpm (full load) is a variable-volume, variable pressure axial piston pump and provides 9 gpm (34.1 lpm) to pilot valves for winch brake release, winch speed shifting and swing brake release.

These five pumps are furnished with a manual pump disconnect.

A sixth pump, driven off the rear of engine camshaft at 2600 rpm is a gear pump and provides 18 gpm (68.1 lpm) to the steering circuit.

Total flow for this system at governed engine speed is 193 gpm (730.5 lpm). High pressure oil leaving the pump to the swing and outrigger circuits is filtered to 20 microns to protect seals in cylinders, valves and motors, before entering the functioning circuits. Returning oil is filtered in two bypass type filters to 10 microns before entering the reservoir.

The 160 gal. (606 liter) reservoir is located on the right side of carrier. Pumps, valves, cylinders and motors are readily accessible and easy to service. Control valves are four-way, three position type with low effort spools and pilot-operated relief valves for quick, smooth response. Swing valve is pressure compensated. Cable linkage connects valves to control levers. Oil cooler is standard.



**SWING UNIT:** Hydraulic motor driving through double reduction plus single planetary gear reducer (51.1) to pinion gear. 360° continuous rotation to 3 RPM.

**SWING GEAR:** Internal cut spur with 107 teeth 42.8" (1087 mm) P.D.

**SWING BRAKE:** Caliper disc brake integral with swing gear reducer, manually applied with swing brake pedal for slow dynamic stopping or manually applied with swing holding brake lever for static holding. Holding brake is spring applied and hydraulically released by detenting swing brake lever.

**HOUSE LOCK:** Two position (front and rear) pin-in-hole lock manually engaged with house lock lever in cab is standard. A positive 360° position lock is optional.

**FASTENING TO LOWER:** Single row ball bearing Swing Circle® integral with swing gear. Welded to carrier frame and bolted to rotating frame. Bearing is protected from dust by labyrinth seal.

**ROTARY MANIFOLD:** Sealed rotary swivel for air and hydraulic hose connections between rotating upper and carrier. Quickly removable from above or below for servicing. Electrical swivel is mounted on top of air and hydraulic swivel.

**COUNTERWEIGHT:** 7000 lb. (3175 kg).

## CARRIER

P&H 8 x 4



**FRAME:** All-welded unitized construction assures rigidity and permanent alignment of swing bearing and rotating upper machinery. Fabricated of rectangular main frame beams of high strength 80,000 psi minimum yield alloy steel and reinforced with box cross members of high strength 80,000 psi minimum yield alloy steel. Reinforced 50,000 psi yield high strength steel channel ahead of front outriggers.

**LIGHTS:** Dual headlights, tail lights, stop lights, front and rear directional signals with emergency flashers, rear license plate light, front, rear and side clearance lights with integral reflectors, dome light, and front identification lights.

**EQUIPMENT (STANDARD):** Front bumper, full fenders, tow hooks front and rear, carrier-mounted boom rack, and sliding engine hood.

**EQUIPMENT (OPTIONAL):** Back-up warning device, cold weather starting aid, Jacobs engine brake, fire extinguisher, flood lights, spare wheel, front bumper float (required for 360° ratings), anti-two block device, air dryer, and dunnage boxes.



**CAB:** Low profile environmental cab of steel construction is mounted forward of the front suspension on the left side of the carrier frame. Cab is cushion mounted for vibration dampening and noise reduction. Large safety glass windows are used throughout, providing full view in all directions. Operators four-way adjustable seat has torsion suspension.

**CAB EQUIPMENT:** Contains all roading controls and instrumentation. Includes illuminated instrument panel with speedometer, tachometer, hour meter, voltmeter and warning light, three (3) air pressure gauges with warning lights, fuel gauge, oil pressure gauge with warning lights, water temperature gauge with warning lights, master ignition switch, engine start and stop buttons. Panel also includes switches for highway lights, dome light, windshield wiper and washer (opt.), engine brake (opt.), engine starting aid (opt.), heater, defroster, turn signals. Right side console includes inter-axle differential lock, transmission shift lever and parking brake. Other cab equipment includes cigarette lighter, engine condition warning alarm, air horns, seat belt and West Coast rear view mirror.



**OUTRIGGERS:** Patented hydraulic scissor type with removable floats — eight double-acting hydraulic cylinders for independent horizontal and vertical motion of each beam, solenoid valve controlled. Holding valves on vertical cylinders. Patented remote controlled air operated ratchet and pawl locks. Outrigger control stations on either side of carrier are standard.

**OUTRIGGER HOUSINGS:** Two independent housings front and rear, pin-connected and removable. 100,000 PSI min. yield high strength alloy steel construction.

**OUTRIGGER BEAMS:** 100,000 PSI min. yield high strength alloy steel box extending to a maximum of 11' 4-5/16" (3.46 m) from center of carrier (with machine fully raised on outriggers).

**OUTRIGGER FLOATS:** Removable forged aluminum floats with storage on carrier.

**FRONT AXLE:** Rockwell FL951 tubular tandem.

**REAR AXLE:** Rockwell SSHD single reduction, ratio 6.83:1 with inter-axle differential (6.17:1 with optional 6L71TAC engine.)

**SUSPENSION:** Front — Reyco four-spring, mounted tandem with torque rods. Rear — Hendrickson solid bogie, mounted tandem with torque rods.

**STEERING:** Ross HF hydraulic powered gear and integral valve with Garrison dual hydraulic power assist cylinders on axles, 18" (457 mm) diameter steering wheel.

**TIRES:** Standard - Eight (8) - 11.00 x 20 14 ply — rear, with Four (4) 15 x 22.5 16 ply — front. Optional - 12.00 x 20 14-ply — rear, 16.5 x 22.5 16 ply — front or 12.00 x 20 18 ply XZA Michelin — front and rear.

**SERVICE BRAKES:** Rockwell Stopmasters on front. Maxi safety brakes on rear. Air on all eight wheels — shoe type with separate front and rear air reservoirs for safety.

**PARKING BRAKES:** Maxi-spring set, air release on rear wheels.



## POWER PLANT:

ENGINE:	STANDARD	OPTIONAL
Make		Detroit Diesel
Model	6V-53T	6L71TAC
Type		Direct Injection Diesel
No. of Cylinders	6	6
Bore x Stroke, In.	3.875 x 4.5	4.25 x 5.0
	mm	(98 x 114)
Displacement, In. <sup>3</sup>	318	426
	Liters	(5.2)
		(6.9)
Cycles	2	2
Air Induction	Turbocharged	Turbocharged

**TRANSMISSION:**

Make	Fuller	Fuller
Model	RT6613	RTO9513
	Road ranger	Road ranger
	Twin counter- shaft	Twin counter- shaft
	13-speed Forward	13-speed Forward
	2-speed Reverse	2-speed Reverse

**Clutch:** Spicer 14" (355.6 mm) two plate with upshift clutch brake.

**RATINGS:**

Horsepower, Gross	225 @ 2600 RPM SAE (168 kw)	270 @ 2100 RPM SAE (201 kw)
-------------------	--------------------------------	--------------------------------

**PUMP DRIVES:** Gear driven off carrier engine with manual disconnect for travel.

Drive ratio	1:1 on all pads	1.26:1 on all pads
-------------	-----------------	--------------------

**PERFORMANCE:** Speed and gradeability based on 76,500 pounds G.V.W. and may vary due to engine performance, vehicle weights and tire options.

Low gear	2.6 MPH (4.2 km/h)	3.4 MPH (5.5 km/h)
High gear	47 MPH (75.7 km/h)	48.7 MPH (78.4 km/h)
Max. grade	43%	41%

**ACCESSORIES:**

Air Cleaner	Two-stage dry type — replaceable element
Oil Filter	Full-flow with replaceable element
Fuel Filter	Heavy duty with replaceable element
Fuel Tank	FHWA approved (Left side of carrier) 80 gal. (303 liters) cap.
Cooling Radiator	Liquid-pressurized, recirculating by-pass Fin and tube core, thermostat controlled
Fan	6 Blade, suction type, 26 in. (660 mm) dia.
Starting	12 volt motor
Charging	12 volt system with 65 amp. alternator, negative ground
Battery	1 — 385 amp. hour
Compressor, air	12 CFM
Governor, air	105-120 PSI

**SPECIAL EUROPEAN OPTIONS:** Winch spooling rollers, electrical load moment device with anti-two block, winch minimum rope wrap shut-off.

**VEHICLE WEIGHTS:** Include standard engine, standard manual boom (forward in travel position), standard main winch and cable, standard tires, 80 gals. fuel, and counterweight.

	G.V.W.	Front Axle	Rear Axle
	73,110 lb. (33,161 kg)	28,606 lb. (12,975 kg)	44,504 lb. (20,185 kg)
Effect on axle loads by adding these items:			
No. 16 auxiliary winch with cable	+ 1151 lb. (522 kg)	- 453 lb. (205 kg)	+ 1604 lb. (728 kg)
No. 10 auxiliary winch with cable	+ 231 lb. (105 kg)	- 94 lb. (43 kg)	+ 325 lb. (147 kg)
Eight 12:00x20 rear tires	+ 136 lb. (62 kg)	0	+ 136 lb. (62 kg)
Boom extension	+ 1266 lb. (574 kg)	+ 867 lb. (393 kg)	+ 399 lb. (181 kg)
Jib (stored)	+ 1056 lb. (479 kg)	+ 317 lb. (144 kg)	+ 739 lb. (335 kg)
Auxiliary sheave (with mounting)	+ 98 lb. (44 kg)	+ 166 lb. (75 kg)	- 68 lb. (31 kg)
8.5 ton weighted hook (stowed)	+ 265 lb. (120 kg)	+ 429 lb. (195 kg)	- 164 lb. (74 kg)
20 ton hook block (stowed)	+ 580 lb. (263 kg)	+ 939 lb. (426 kg)	- 359 lb. (163 kg)
40 ton hook block (stowed)	+ 730 lb. (331 kg)	+ 1182 lb. (536 kg)	- 452 lb. (205 kg)
Propane heater with tank	+ 48 lb. (22 kg)	+ 2 lb. (1 kg)	+ 46 lb. (21 kg)
Fifth float	+ 166 lb. (75 kg)	—	—
Dunnage box option	+ 304 lb. (138 kg)	+ 105 lb. (48 kg)	+ 199 lb. (90 kg)
Optional engine, transmission, 6L71TAC	+ 548 lb. (248 kg)	+ 713 lb. (323 kg)	- 165 lb. (75 kg)

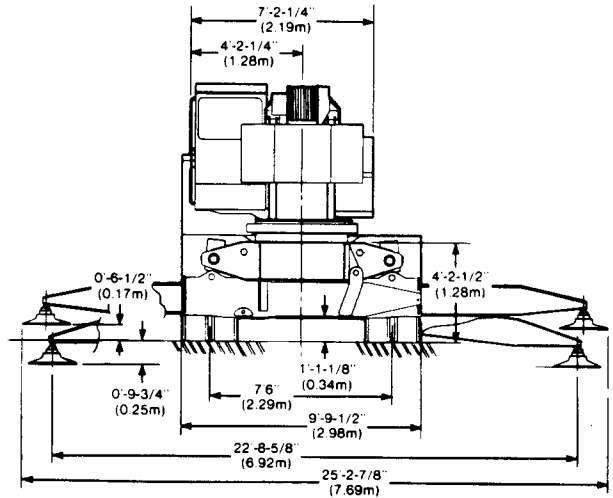
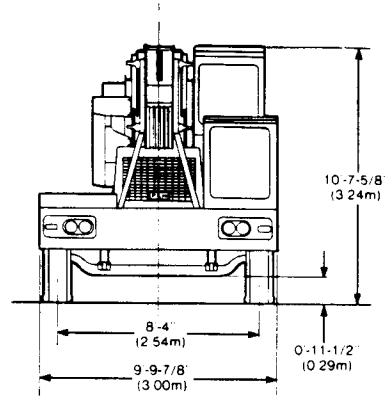

## general dimensions

VEHICLE TURNING CIRCLE - 91'-2" (27.79m)  
VEHICLE CLEARANCE CIRCLE - 100'-2" (30.53m)

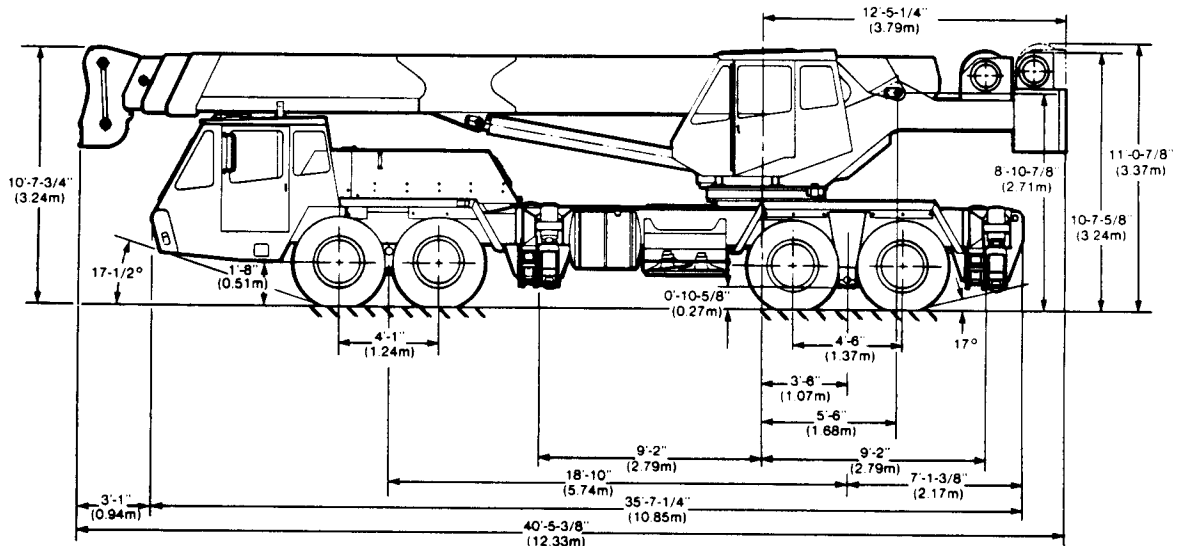

105J1337

# operating instructions

This P&H crane meets the requirements of ANSI B30.15 (1973). Boom structure (boom, lattice extension and jib) has been tested per SAE J1063, machine stability tested per SAE J765. LOAD RATINGS shown apply only to machine as originally manufactured and equipped by Harnischfeger Corporation.

1. LOAD RADIUS is horizontal distance from axis of rotation (before loading) to center of vertical hoist line (after loading). Actual working radii should be an accurate measurement.
2. Boom, lattice extension and jib point height dimensions are measured from ground to center of load sheave.
3. LOADED BOOM ANGLE is the angle between the boom base section and the horizontal axis after lifting rated load at rated radius. Loaded boom angles shown are with rated loads applied and provide an approximation of the LOAD RADIUS at the specified BOOM LENGTH (includes lattice extension). The boom angle before loading should be slightly greater to account for boom deflection.
4. LOAD RATINGS shown are for machine with counterweight as shown, leveled and standing on firm, uniform supporting surface. Ratings are based on freely suspended loads and are not more than 85% of minimum tipping loads. Ratings above the bold horizontal line are based on machine's hydraulic or structural competence and not on machine stability (tipping conditions).
5. To determine LOAD RATINGS in-between those shown on chart, proceed as follows:
  - a. for boom lengths not shown, use rating of next longer rated boom;
  - b. for load radii not shown, use rating of next longer rated radius.
6. Deduct weight from LOAD RATINGS of all suspended load handling devices such as hooks, hookblocks, slings, buckets, etc. as they are considered part of the load. See table for deductions.

7. Deduct weight from LOAD RATINGS of fixed boom attachments (jib, boom extension) either stowed or erected, as they reduce capacity of boom. See table for deductions.
8. LOAD RATINGS shown make no allowance for such factors as wind effect on lifted loads, ground conditions, out-of-level, operating speed or conditions that could be detrimental to safe operation of this machine. The operator must judge these factors and reduce ratings accordingly.
9. "ON OUTRIGGERS" LOAD RATINGS are based on outriggers fully extended and set at a distance of 11 ft. 4-5/16 in. (3.46 m) from longitudinal axis of carrier to vertical axis of outrigger float. Machine must be level and supported by outriggers with tires free of supporting surface.
10. "ON TIRES" LOAD RATINGS are based on lift limitations and conditions of tires inflated to pressures shown in table. Over rear "Travel" ratings are limited to travel speed less than 5 mph (8 kmph) on firm, level ground with load centered over rear of machine and load restrained from swinging.
11. Maximum JIB LOAD RATINGS are based on structural competence. Ratings at any radius shall not exceed BOOM LOAD RATINGS at same radius and shall not exceed maximum ratings shown.
12. Jibs are intended to increase lifting height — not load radius. Maximum JIB LOAD RADIUS shall not exceed maximum BOOM LOAD RADIUS of boom length on which jib is mounted. Jib ratings are based on boom angle.
13. For bucket ratings on jib, deduct 20% from maximum JIB LOAD RATINGS.
14. Method of telescoping boom is selective sequencing with each section extendible a distance of 24 ft. 6 in. (7.47 m). See rating chart.
15. The maximum load which may be telescoped is limited by hydraulic pressure, boom angle and lubrication. It is safe to telescope any load within limits of load rating chart.

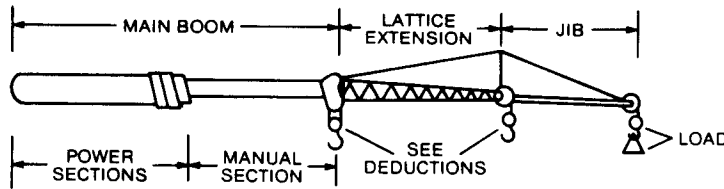

## areas of operation

ON OUTRIGGERS

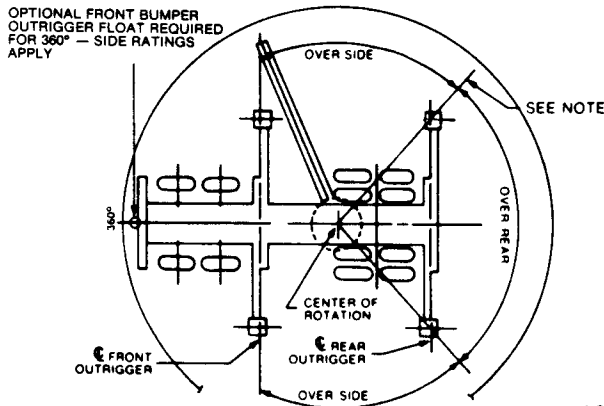

ON TIRES

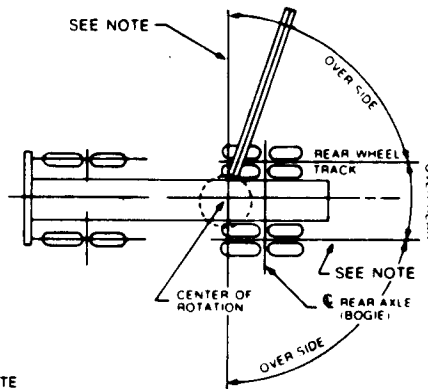

NOTE  
THESE LINES DETERMINE ANY LIMITING POSITION OF ANY LOAD FOR OPERATION WITHIN WORKING AREAS INDICATED

# working ranges

## four section boom with manual section and 7,000 lbs. counterweight

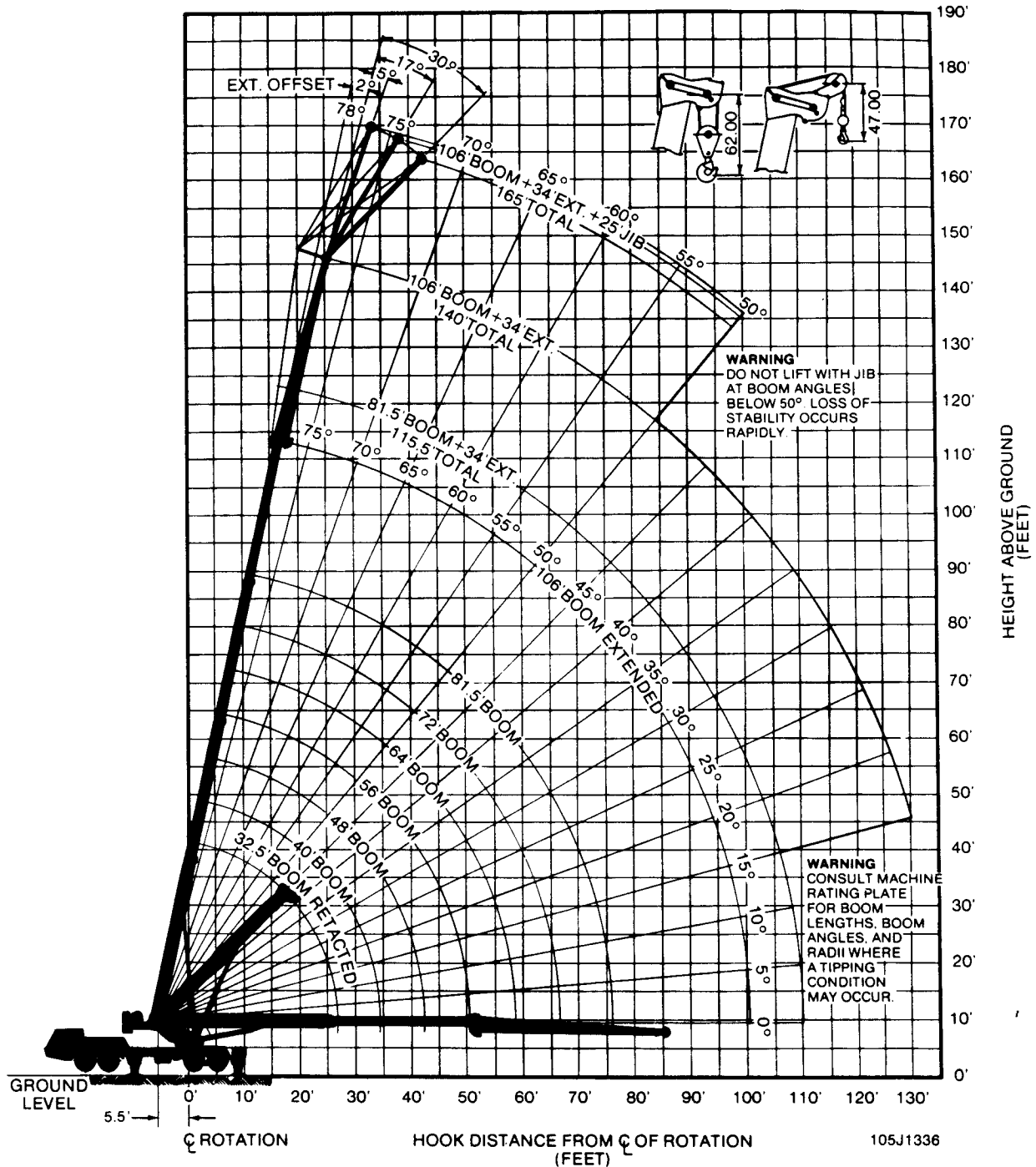

**PCSA CLASS 10—182 "on outriggers"**

**rated crane loads in pounds — boom in over side and over rear work areas with outriggers fully extended and set**

LOAD RADIUS (FEET)	BOOM LENGTH (FEET)																				
	32.5		40		48		56		64		72		81.5		106		115.5		140		
	LOADED BOOM ANGLE Δ	RATED LOAD POUNDS	LOADED BOOM ANGLE Δ	RATED LOAD POUNDS	LOADED BOOM ANGLE Δ	RATED LOAD POUNDS	LOADED BOOM ANGLE Δ	RATED LOAD POUNDS	LOADED BOOM ANGLE Δ	RATED LOAD POUNDS	LOADED BOOM ANGLE Δ	RATED LOAD POUNDS	LOADED BOOM ANGLE Δ	RATED LOAD POUNDS	LOADED BOOM ANGLE Δ	RATED LOAD POUNDS	LOADED BOOM ANGLE Δ	RATED LOAD POUNDS	LOADED BOOM ANGLE Δ	RATED LOAD POUNDS	LOAD RADIUS (FEET)
10	64	80000	70	70000	73	67000	76	62000	82000	76	50000	50000									10
12	60	72000	66	64000	64000	71	57000	57000	76	44000	44000	76	40000	40000							12
15	54	60000	60000	62	57000	57000	60	43000	43000	66	37000	37000	72	33000	33000						15
20	41	47000	47000	53	45000	45000	60	43000	43000	66	39500	29500	64	29500	29500						20
25	23	36000	36000	43	35000	35000	53	33000	33000	59	33000	33000	64	29500	29500						25
30				30	29000	29000	44	28000	28000	44	28000	28000	58	25000	25000						30
35				35	23500	23500	46	23000	23000	53	22000	22000	58	20000	20000						35
40				40	18200	18200	48	18200	18200	47	18200	18200	53	17500	17500						40
45				45	18200	18200	38	18200	18200	38	14300	14900	54	14300	14900						45
50				50			9	11500	12200	32	11500	12200	42	11500	12200						50
55				55			21	9300	10000	35	9300	10000	44	9300	10000						55
60				60			27	7600	8300	39	7600	8300	54	8500	8500						60
65				65			14	6200	6800	32	6200	6800	51	7600	7600						65
70				70			24	5000	5700	28	5000	5700	47	6500	6800						70
80				80																	80
90				90																	90
100				100																	100
110				110																	110
120				120																	120
130				130																	130

1. FOR BOOM LENGTHS LESS THAN 115.5 FEET WITH MANUAL SECTION RETRACTED AND LESS THAN 140 FEET WITH MANUAL EXTENDED THE 34 FOOT BOOM EXTENSION RATED LOADS ARE DETERMINED BY BOOM ANGLE ONLY IN THE COLUMN HEADED BY 106 FOOT BOOM FOR BOOM ANGLES NOT SHOWN. USE RATING OF NEXT LOWER BOOM ANGLE.

2. FOR BOOM LENGTHS LESS THAN 115.5 FEET WITH MANUAL EXTENDED AND LESS THAN 140 FEET WITH MANUAL EXTENDED THE 34 FOOT BOOM EXTENSION RATED LOADS ARE DETERMINED BY BOOM ANGLE ONLY IN THE COLUMN HEADED BY 115.5 FOOT BOOM AND 140 FOOT BOOM RESPECTIVELY FOR ANGLES NOT SHOWN. USE RATING OF NEXT LOWER BOOM ANGLE.

329R30

**"on tires"**

**rated crane loads in pounds in — main boom — without outriggers**

LOAD RADIUS (FEET)	BOOM LENGTH (FEET)																				
	32.5		40		48		56		64		72		81.5		106		115.5		140		
	LOADED BOOM ANGLE Δ	RATED LOAD POUNDS	LOADED BOOM ANGLE Δ	RATED LOAD POUNDS	LOADED BOOM ANGLE Δ	RATED LOAD POUNDS	LOADED BOOM ANGLE Δ	RATED LOAD POUNDS	LOADED BOOM ANGLE Δ	RATED LOAD POUNDS	LOADED BOOM ANGLE Δ	RATED LOAD POUNDS	LOADED BOOM ANGLE Δ	RATED LOAD POUNDS	LOADED BOOM ANGLE Δ	RATED LOAD POUNDS	LOADED BOOM ANGLE Δ	RATED LOAD POUNDS	LOADED BOOM ANGLE Δ	RATED LOAD POUNDS	LOAD RADIUS (FEET)
10	64	80000	70	70000	73	67000	76	62000	82000	76	50000	50000									10
12	60	72000	66	64000	64000	71	57000	57000	76	44000	44000	76	40000	40000							12
15	54	60000	60000	62	57000	57000	60	43000	43000	66	37000	37000	72	33000	33000						15
20	41	47000	47000	53	45000	45000	60	43000	43000	66	39500	29500	64	29500	29500						20
25	23	36000	36000	43	35000	35000	53	33000	33000	59	33000	33000	64	29500	29500						25
30				30	29000	29000	44	28000	28000	44	28000	28000	58	25000	25000						30
35				35	23500	23500	46	23000	23000	53	22000	22000	58	20000	20000						35
40				40	18200	18200	48	18200	18200	47	18200	18200	53	17500	17500						40
45				45	18200	18200	38	18200	18200	38	14300	14900	54	14300	14900						45
50				50			9	11500	12200	32	11500	12200	42	11500	12200						50
55				55			21	9300	10000	35	9300	10000	44	9300	10000						55
60				60			27	7600	8300	39	7600	8300	54	8500	8500						60
65				65			14	6200	6800	32	6200	6800	51	7600	7600						65
70				70			24	5000	5700	28	5000	5700	47	6500	6800						70
80				80																	80
90				90																	90
100				100																	100
110				110																	110
120				120																	120
130				130																	130

1. RATINGS ABOVE THE HEAVY LINE ARE BASED ON STRUCTURAL COMPETENCE AND NOT ON MACHINE STABILITY.

2. WHEN LIFTING A LOAD, ALL POWERED SECTIONS OF THE BOOM MUST BE EXTENDED EQUALLY.

3. BOOM RATINGS MUST BE REDUCED BY WEIGHT OF BOOM AT TACHMENTS AND LOAD HANDLING DEVICES SEE TABLE.

329R30

**Jib ratings**

Minimum Boom Angle	MAXIMUM LOAD RATINGS IN POUNDS	
	3.5°	17.5°
78°	5000	4200
75°	4600	4000
70°	4100	3700
65°	3500	3200
60°	3100	2900
55°	2600	2500
50°	2200	2100

JIB CAPACITY NOTES

1. MAXIMUM JIB LOAD RATINGS ARE BASED ON STRUCTURAL COMPETENCE AND DO NOT EXCEED 85% OF TIPPING LOAD WITH FULL EXTENSION. JIBS EQUIPPED WITH 10' OUTRIGGERS IS RECOMMENDED TO BE USED WITH 10' OUTRIGGERS.
2. FOR BRACKET RATINGS ON JIB DEDUCT 20% FROM MAXIMUM JIB LOAD RATINGS.
3. WARNING: DO NOT LIFT WITH JIB AT BOOM ANGLES BELOW 50° LOSS OF STABILITY OCCURS RAPIDLY.
4. WARNING: DO NOT EXCEED 130' FOOT LOAD RADIUS WITH ERECTED JIB OR A TIPPING CONDITION WILL OCCUR.

**LOAD RATINGS DEPEND ON TIRE CAPACITY AND CONDITION. INFLATED PER TABLE.**

SIZE	TIRE INFLATION	
	STAT	CREEP
11.00-20-14 PR	110 PSI	110 PSI
12.00-20-14 PR	100 PSI	100 PSI

RATINGS ABOVE THE HEAVY LINE ARE BASED ON STRUCTURAL COMPETENCE AND NOT ON MACHINE STABILITY. STABILITY RATINGS DO NOT EXCEED 75% OF TIPPING LOADS WITH AUXILIARY SHEAVE ON BOOM POINT AND STOWED BOOM EXTENSION.

WHEN TRANSPORTING A LOAD MACHINE MUST BE ON FIRM LEVEL SURFACE WITH MECHANICAL HOUSELOCK ENGAGED AND LOAD CENTERED OVER REAR OF MACHINE AND RESTRAINED FROM SWINGING. DO NOT EXCEED 5 MPH (8 KM/PH) VEHICLE SPEED. CREEP IS MOTION FOR LESS THAN 200 FT (60.9 M) IN A 30 MIN PERIOD AND NOT EXCEEDING 1 MPH.

**LOAD RATINGS DEPEND ON TIRE CAPACITY AND CONDITION. INFLATED PER TABLE.**

LOAD RADIUS (FEET)	STATIONARY RATINGS		TRAVEL RATINGS	
	OVER REAR	OVER SIDE	OVER REAR	OVER SIDE
10	35000	27000	31000	22600
12	32200	22600	28900	20300
15	28500	16200	25200	17400
20	20500	9400	19700	14000
25	14200	5600	13600	11400
30	10300	3300	—	—
35	7500	1700	—	—
40	5600	—	—	—
45	4100	—	—	—
50	2900	—	—	—
55	2000	—	—	—

WARNING: LIFTS WITH JIB OR BOOM EXTENSION IN WORKING POSITION ARE PROHIBITED.

TO HELP PREVENT TIPPING CONDITIONS WHEN "LIFTING ON TIRES", IT IS RECOMMENDED THAT:

1. MINIMUM BOOM LENGTHS BE USED, NOT EXCEEDING 84 FEET
2. OUTRIGGERS BE EXTENDED AS FAR AS POSSIBLE AND CLEAR OF GROUND

WHEN LIFTING A LOAD, ALL POWERED SECTIONS OF THE BOOM MUST BE EXTENDED EQUALLY.

32U1785

WARNING: DO NOT EXCEED RATED LOAD AT RADIUS SHOWN OR TIPPING WILL OCCUR.

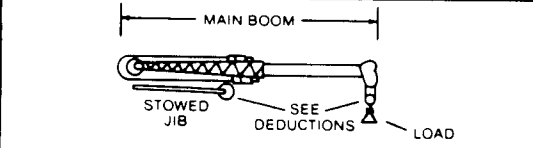
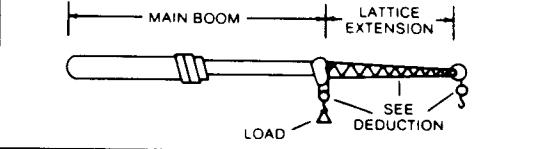
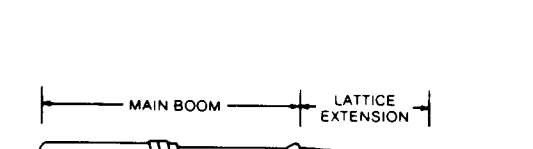

## deductions to be made from rated loads

	<p style="text-align: center;">DEDUCTIONS TO BE MADE FROM MAIN BOOM RATED LOADS (IN POUNDS) (Hoisting From Boom Point)</p> <table border="1" style="width: 100%; border-collapse: collapse;"> <tr> <td colspan="2">JIB (STOWED)</td> <td colspan="2" style="text-align: center;">400</td> </tr> <tr> <td>HOOK BLOCK</td> <td>ON BOOM POINT</td> <td>ON LATTICE EXTENSION</td> <td>ON JIB</td> </tr> <tr> <td>40 Ton 4 Sheave</td> <td style="text-align: center;">730</td> <td style="text-align: center;">—</td> <td style="text-align: center;">—</td> </tr> <tr> <td>20 Ton 1 Sheave</td> <td style="text-align: center;">580</td> <td style="text-align: center;">2700</td> <td style="text-align: center;">—</td> </tr> <tr> <td>8.5 Ton Ball Hook</td> <td style="text-align: center;">265</td> <td style="text-align: center;">2300</td> <td style="text-align: center;">5100</td> </tr> </table>	JIB (STOWED)		400		HOOK BLOCK	ON BOOM POINT	ON LATTICE EXTENSION	ON JIB	40 Ton 4 Sheave	730	—	—	20 Ton 1 Sheave	580	2700	—	8.5 Ton Ball Hook	265	2300	5100
JIB (STOWED)		400																			
HOOK BLOCK	ON BOOM POINT	ON LATTICE EXTENSION	ON JIB																		
40 Ton 4 Sheave	730	—	—																		
20 Ton 1 Sheave	580	2700	—																		
8.5 Ton Ball Hook	265	2300	5100																		
	<p style="text-align: center;">DEDUCTIONS TO BE MADE FROM LATTICE EXTENSION RATED LOADS (IN POUNDS) (Hoisting From Extension Point)</p> <table border="1" style="width: 100%; border-collapse: collapse;"> <tr> <td colspan="2">JIB (STOWED)</td> <td colspan="2" style="text-align: center;">400</td> </tr> <tr> <td>HOOK BLOCK</td> <td>ON BOOM POINT</td> <td>ON LATTICE EXTENSION</td> <td>ON JIB</td> </tr> <tr> <td>40 Ton</td> <td style="text-align: center;">500</td> <td style="text-align: center;">—</td> <td style="text-align: center;">—</td> </tr> <tr> <td>20 Ton</td> <td style="text-align: center;">400</td> <td style="text-align: center;">580</td> <td style="text-align: center;">—</td> </tr> <tr> <td>8.5 Ton</td> <td style="text-align: center;">200</td> <td style="text-align: center;">265</td> <td style="text-align: center;">1400</td> </tr> </table>	JIB (STOWED)		400		HOOK BLOCK	ON BOOM POINT	ON LATTICE EXTENSION	ON JIB	40 Ton	500	—	—	20 Ton	400	580	—	8.5 Ton	200	265	1400
JIB (STOWED)		400																			
HOOK BLOCK	ON BOOM POINT	ON LATTICE EXTENSION	ON JIB																		
40 Ton	500	—	—																		
20 Ton	400	580	—																		
8.5 Ton	200	265	1400																		
	<p style="text-align: center;">DEDUCTIONS TO BE MADE FROM JIB RATED LOADS (IN POUNDS) (Hoisting From Jib Point)</p> <table border="1" style="width: 100%; border-collapse: collapse;"> <tr> <td>HOOK BLOCK</td> <td>ON BOOM POINT</td> <td>ON LATTICE EXTENSION</td> <td>ON JIB</td> </tr> <tr> <td>40 Ton</td> <td style="text-align: center;">400</td> <td style="text-align: center;">—</td> <td style="text-align: center;">—</td> </tr> <tr> <td>20 Ton</td> <td style="text-align: center;">300</td> <td style="text-align: center;">500</td> <td style="text-align: center;">—</td> </tr> <tr> <td>8.5 Ton</td> <td style="text-align: center;">200</td> <td style="text-align: center;">200</td> <td style="text-align: center;">265</td> </tr> </table>	HOOK BLOCK	ON BOOM POINT	ON LATTICE EXTENSION	ON JIB	40 Ton	400	—	—	20 Ton	300	500	—	8.5 Ton	200	200	265				
HOOK BLOCK	ON BOOM POINT	ON LATTICE EXTENSION	ON JIB																		
40 Ton	400	—	—																		
20 Ton	300	500	—																		
8.5 Ton	200	200	265																		

PERMISSIBLE HOIST LINE LOAD IN POUNDS			
PARTS OF LINE	P&H 16 MAIN WINCH	P&H 16 AUXILIARY WINCH	P&H 10-1 AUXILIARY WINCH
1	10,000	10,000	7,150
2	20,000	20,000	14,300
3	30,000	30,000	21,450
4	40,000	—	—
5	50,000	—	—
6	60,000	—	—
7	70,000	—	—
8	80,000	—	—

HOIST LINE WIRE ROPE				
TYPE	3/4-8 x 19 IWRC	P&H TYPE 25 3/4-6 x 25F IWRC	9/16-8 x 19 IWRC	P&H TYPE 25 9/16-6 x 25F IWRC
BREAKING STRENGTH	51,800 lb	58,800 lb	29,400 lb	33,600 lb
PERMISSIBLE STRENGTH	14,800 lb	16,800 lb	8,400 lb	9,600 lb



**NOTE:** All designs, specifications and components of the equipment described above are subject to change at the manufacturer's sole discretion at any time without advance notice. Data published herein is informational in nature and shall not be construed to warrant suitability of the machine for any particular purpose as performance may vary with the conditions encountered. The only warranty applicable is our standard written warranty for this machine. Manufactured and sold in conformance with U. S. Department of Commerce Commercial Standard CS 90.58



# PH 7900

**VEHICLE WEIGHTS:** include standard engine, standard manual boom (forward in travel position), standard main winch and cable, standard tires, 80 gals. fuel, and counterweight.

	G.V.W.	Front Axle	Rear Axle
	73,110 lb. (33,181 kg)	28,808 lb. (12,976 kg)	44,504 lb. (20,185 kg)
<b>Effect on axle loads by adding these items:</b>			
No. 16 auxiliary winch with cable	+ 1151 lb. (522 kg)	- 453 lb. (205 kg)	+ 1604 lb. (728 kg)
No. 10 auxiliary winch with cable	+ 231 lb. (105 kg)	- 94 lb. (43 kg)	+ 325 lb. (147 kg)
Eight 12:00x20 rear tires	+ 136 lb. (62 kg)	0	+ 136 lb. (62 kg)
Boom extension	+ 1268 lb. (574 kg)	+ 867 lb. (393 kg)	+ 399 lb. (181 kg)
Jib (stored)	+ 1056 lb. (479 kg)	+ 317 lb. (144 kg)	+ 739 lb. (335 kg)
Auxiliary sheave (with mounting)	+ 98 lb. (44 kg)	+ 166 lb. (75 kg)	- 68 lb. (31 kg)
8.5 ton weighted hook (stowed)	+ 266 lb. (120 kg)	+ 428 lb. (195 kg)	- 164 lb. (74 kg)
20 ton hook block (stowed)	+ 580 lb. (263 kg)	+ 939 lb. (426 kg)	- 359 lb. (163 kg)
40 ton hook block (stowed)	+ 730 lb. (331 kg)	+ 1182 lb. (536 kg)	- 452 lb. (205 kg)
Propane heater with tank	+ 48 lb. (22 kg)	+ 2 lb. (1 kg)	+ 46 lb. (21 kg)
FIRh float	+ 166 lb. (75 kg)	-	-
Dunnage box option	+ 304 lb. (138 kg)	+ 105 lb. (48 kg)	+ 199 lb. (90 kg)
Optional engine, transmission, 6L71TAC	+ 548 lb. (248 kg)	+ 713 lb. (323 kg)	- 165 lb. (75 kg)

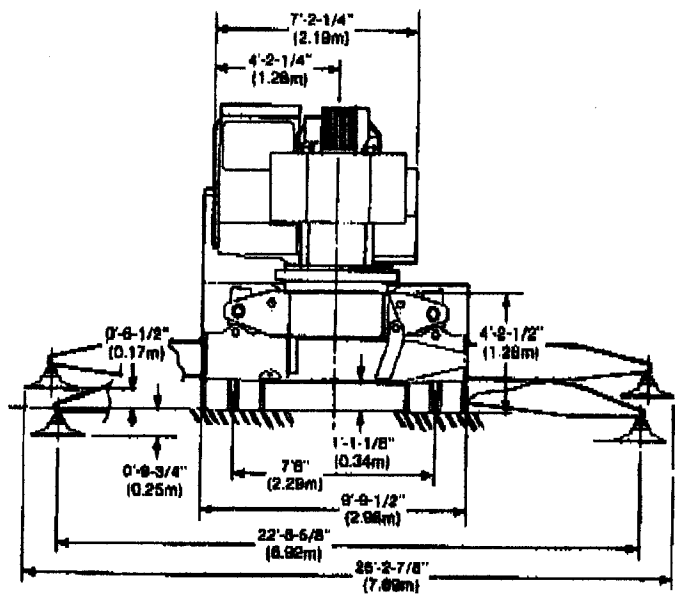
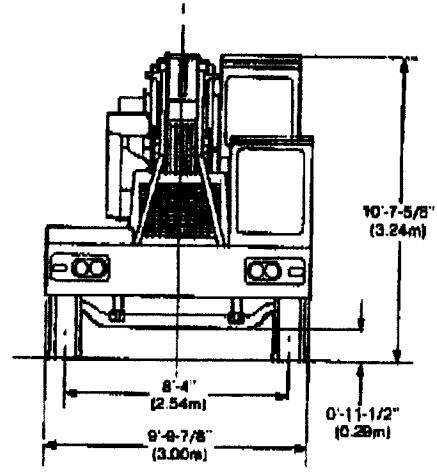

## general dimensions

VEHICLE TURNING CIRCLE - 91'-2" (27.79m)  
VEHICLE CLEARANCE CIRCLE - 100'-2" (30.53m)

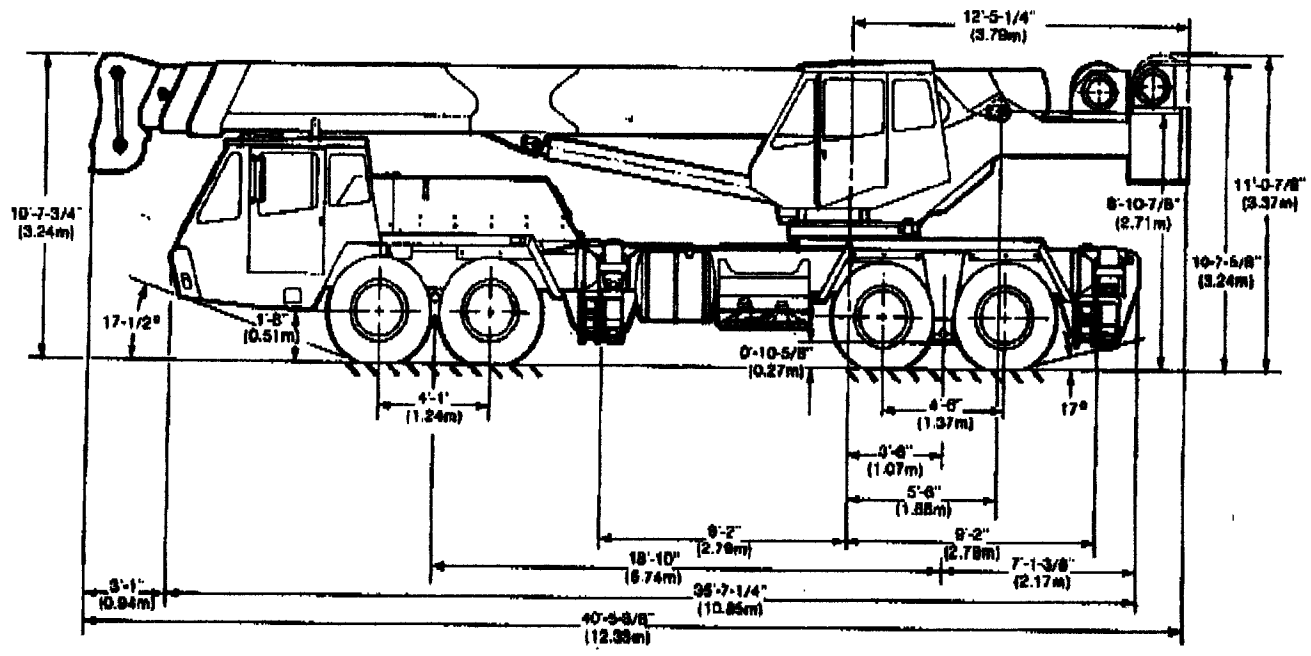

# working ranges

## four section boom with manual section and 7,000 lbs. counterweight

