

diagram

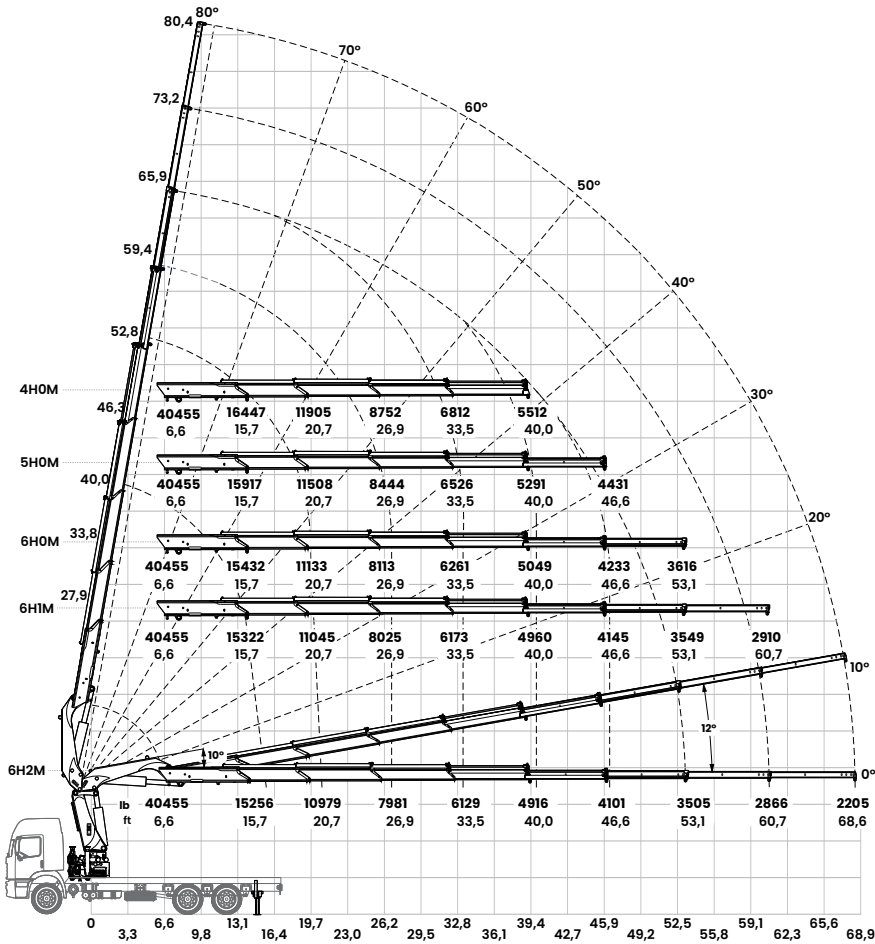

specification

max. manual vertical reach	80,4 ft
max. manual horizontal reach	68,6 ft
max. hydraulic vertical reach	65,9 ft
max. hydraulic horizontal reach	53,1 ft
front stabilizer spread	19,7 ft
boom elevation angle	80°
slewing angle	400°
slewing torque	37,39 kN.m
max. operating pressure	4061 psi
dead weight - 4H0M / 5H0M	8891 lb / 9218 lb
dead weight - 6H0M / 6H1M / 6H2M	9524 lb / 9665 lb / 9756 lb
fitting space required	5,2 ft
oil tank capacity	36,98 gal
min. gross vehicle weight (GVW)	50706 lb*

dimensions

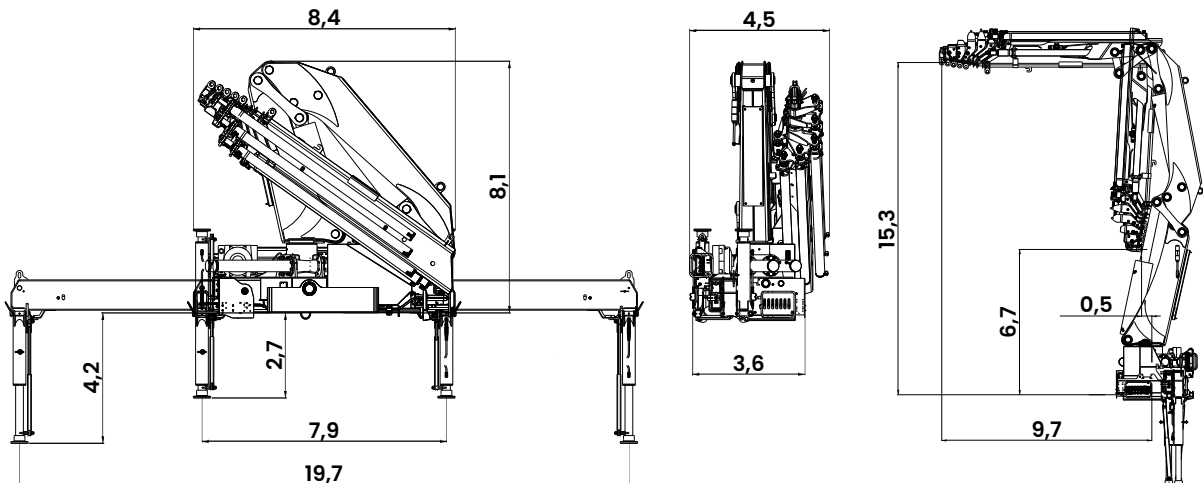

* through vehicle integration study