



HC 165

165 tons capacity
Crawler Crane

DATASHEET IMPERIAL

HC 165



WORKS FOR YOU.™

	Page:
Key	3
Highlights	3
Dimensions	4
Range Diagram	
77SI Hammerhead Tip Boom	6
Load Charts	
With 77SI Hammerhead Tip Boom and 102,000 Pound Upper Counterweight	7
With 77SI Hammerhead Tip Boom and 116,400 Pound Counterweight	10
Range Diagram	
77SI Offset Tip Boom	14
Load Charts	
With 77SI Offset Tip Boom and 102,000 Pound Upper Counterweight	15
With 77SI Offset Tip Boom and 116,400 Pound Counterweight	18
Range Diagram	
77SI Hammerhead Tip Boom, #16HL Jib	22
Load Charts	
With 77SI Hammerhead Tip Boom and 102,000 Pound Upper Counterweight, #16HL Jib	23
With 77SI Hammerhead Tip Boom and 116,400 Pound Counterweight, #16HL Jib	30
Range Diagram	
77SI Offset Tip Boom, #16HL Jib	38
Load Charts	
With 77SI Offset Tip Boom and 102,000 Pound Upper Counterweight, #16HL Jib	39
With 77SI Offset Tip Boom and 116,400 Pound Counterweight, #16HL Jib	48
Technical Description	
Hydraulic Crawler Crane	58
Hoist Drum Performance	59
Transport Example	
for HC 165	60

HIGHLIGHTS

HC 165

- ▶ 165 tons maximum lifting capacity
 - ▶ 270 ft maximum length of main boom
 - ▶ 80 ft maximum jib
 - ▶ 320 ft maximum boom and jib length
 - ▶ 310 horsepower Cummins engine
 - ▶ Optional boom tips
 - ▶ Optional 3rd drum configurations
 - ▶ Increased capacity at working radii with optional counterweight
 - ▶ Proven American 77" boom and 16HL jib
 - ▶ Fully self-erectable
 - ▶ Power up / power down and freefall on main, auxiliary and optional third drum
 - ▶ Quiet operator's cab with spacious width
 - ▶ 360° viewing range
 - ▶ Two speed travel
 - ▶ Powerful, high speed hoist drums
- ▶ **The ultimate crane!**



KEY



Counterweight

DIMENSIONS

HC 165

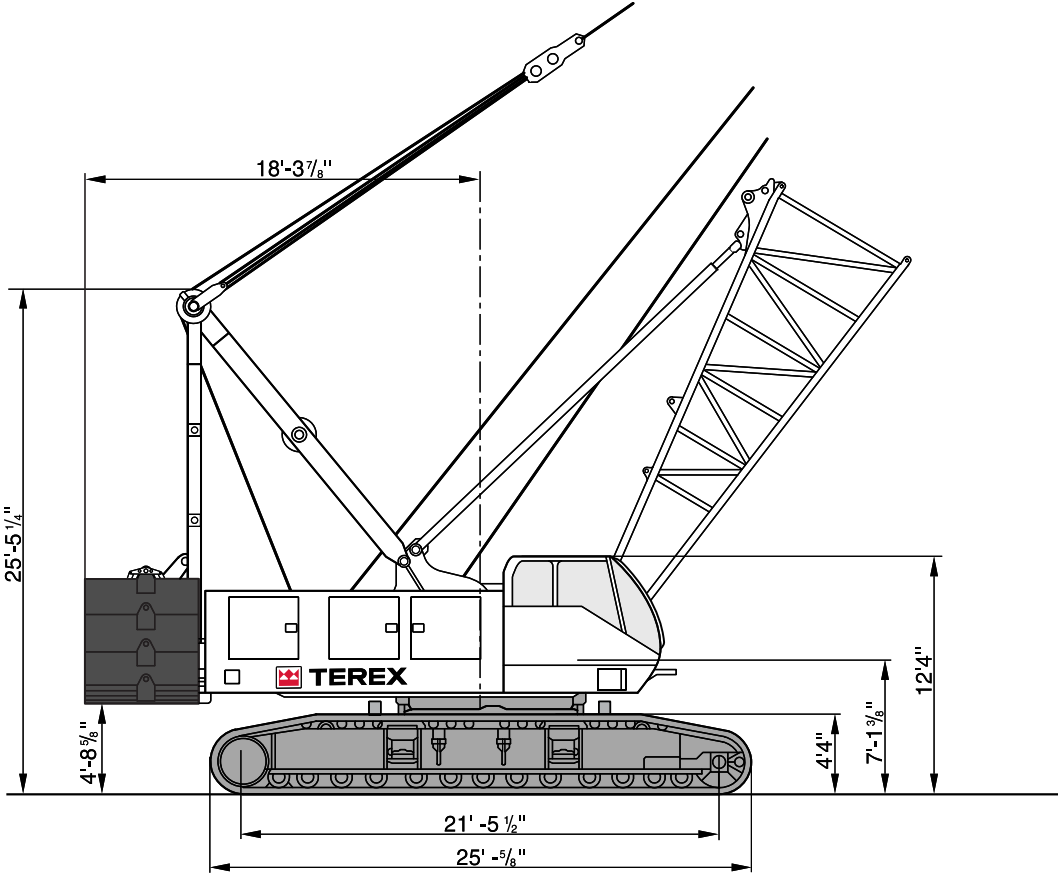

DIMENSIONS

HC 165

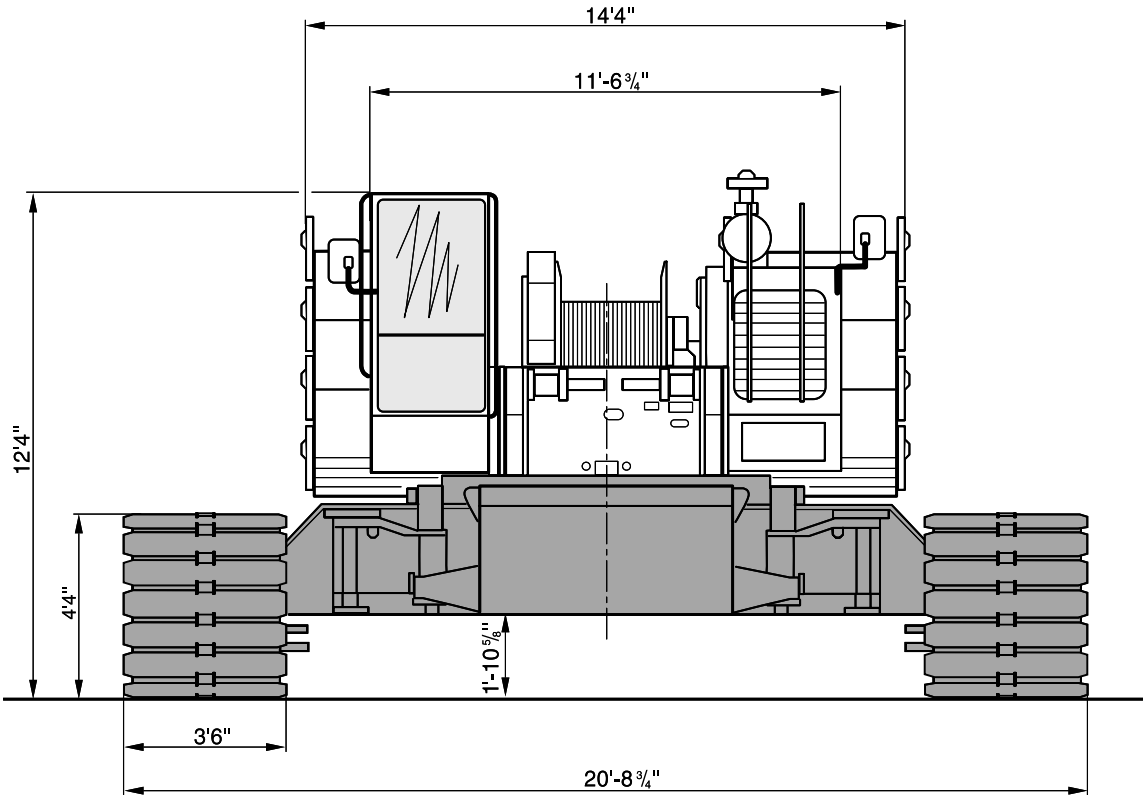

RANGE DIAGRAM

HC 165

77SI Hammerhead Tip Boom

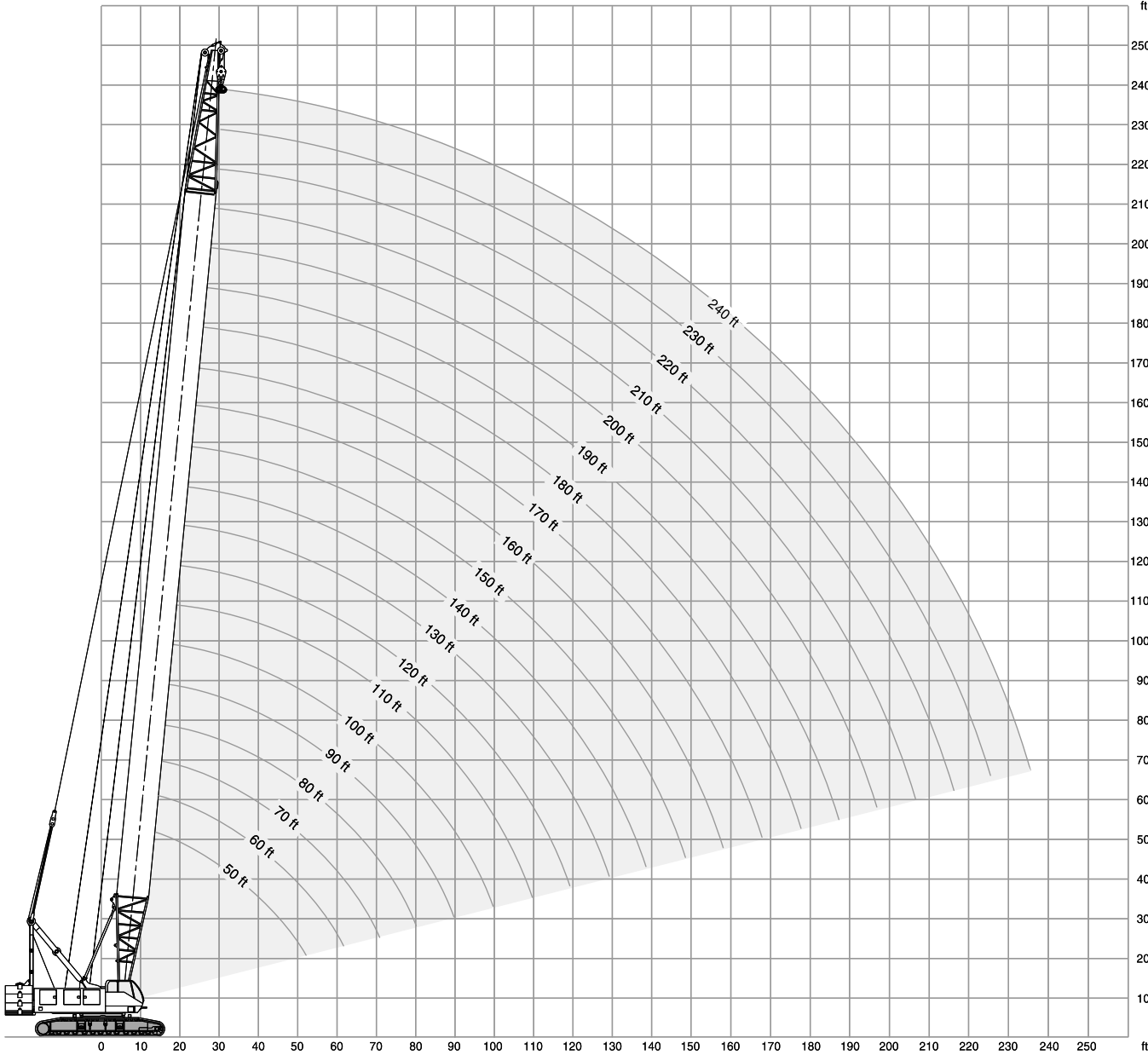

LOAD CHART

HC 165

With 77SI Hammerhead Tip Boom and 102,000 Pound Upper Counterweight

102,000 lb				360°				ANSI B 30.5			
50' Boom length				100' Boom length							
Radius (Feet)	Boom Angle (Degrees)	360 Degree Rating (Pounds)	From Boom Pt. to Ground (Feet)	Radius (Feet)	Boom Angle (Degrees)	360 Degree Rating (Pounds)	From Boom Pt. to Ground (Feet)				
14	81.9	330,000*	58	20	82.5	271,420	107				
15	80.8	330,000*	57	25	79.6	184,070	106				
20	75.0	270,720	56	30	76.7	138,240	105				
25	68.9	183,870	55	35	73.8	110,090	104				
30	62.7	138,290	52	40	70.8	90,860	102				
35	55.9	110,230	49	50	64.6	66,650	98				
40	48.5	91,140	45	60	58.0	51,790	93				
50	29.5	66,900	32	70	50.9	41,780	85				
				80	43.0	34,740	76				
				90	33.5	29,290	63				
				100	20.3	25,000	42				
60' Boom length				110' Boom length							
15	82.3	330,000*	68	21	82.7	247,920	117				
20	77.5	271,110	67	25	80.6	183,920	117				
25	72.6	184,120	65	30	77.9	138,050	116				
30	67.5	138,460	63	35	75.3	109,880	114				
35	62.2	110,390	61	40	72.6	90,620	113				
40	56.6	91,250	58	50	67.0	66,400	109				
50	44.0	67,040	49	60	61.2	51,520	104				
60	26.7	52,190	35	70	55.0	41,510	98				
				80	48.3	34,500	90				
				90	40.8	29,050	80				
				100	31.8	24,780	66				
				110	19.3	21,340	44				
70' Boom length				120' Boom length							
16	82.6	330,000*	78	22	82.8	228,210	127				
20	79.3	271,310	77	25	81.4	183,750	127				
25	75.1	184,230	76	30	78.9	137,830	126				
30	70.8	138,520	74	35	76.5	109,650	125				
35	66.5	110,420	72	40	74.1	90,370	123				
40	61.9	91,260	70	50	69.0	66,150	120				
50	52.0	67,060	63	60	63.8	51,250	116				
60	40.5	52,210	53	70	58.3	41,230	110				
70	24.6	42,200	37	80	52.5	34,250	103				
				90	46.2	28,800	94				
				100	39.0	24,530	83				
				110	30.4	21,110	68				
				120	18.4	18,270	45				
80' Boom length				130' Boom length							
17	82.8	330,000*	87	23	82.9	211,000	137				
20	80.6	271,390	87	25	82.0	183,560	137				
25	77.0	184,210	86	30	79.8	137,600	136				
30	73.3	138,450	85	35	77.6	109,400	135				
35	69.6	110,320	83	40	75.3	90,090	134				
40	65.7	91,140	81	50	70.7	65,860	131				
50	57.5	66,930	75	60	66.0	50,950	127				
60	48.4	52,090	68	70	61.0	40,910	122				
70	37.7	42,090	57	80	55.8	33,950	115				
80	22.9	34,950	39	90	50.3	28,500	108				
				100	44.2	24,240	98				
				110	37.4	20,820	87				
				120	29.2	17,990	71				
				130	17.6	15,630	47				
90' Boom length											
18	82.9	330,000*	97								
20	81.7	271,410	97								
25	78.5	184,130	96								
30	75.2	138,330	95								
35	71.9	110,190	94								
40	68.5	90,980	92								
50	61.5	66,770	87								
60	53.9	51,910	81								
70	45.4	41,920	72								
80	35.4	34,840	60								
90	21.5	29,360	40								

LOAD CHART

HC 165

With 77SI Hammerhead Tip Boom and 102,000 Pound Upper Counterweight

102,000 lb				360°				ANSI B 30.5			
140' Boom length				170' Boom length							
Radius (Feet)	Boom Angle (Degrees)	360 Degree Rating (Pounds)	From Boom Pt. to Ground (Feet)	Radius (Feet)	Boom Angle (Degrees)	360 Degree Rating (Pounds)	From Boom Pt. to Ground (Feet)				
25	82.6	183,360	147	28	82.9	152,290	177				
30	80.5	137,350	146	30	82.2	136,630	177				
35	78.5	109,150	145	35	80.5	108,370	176				
40	76.4	89,800	144	40	78.8	88,960	175				
50	72.1	65,570	141	50	75.4	64,690	173				
60	67.8	50,640	138	60	71.8	49,710	170				
70	63.3	40,590	133	70	68.3	40,000	166				
80	58.6	33,650	127	80	64.6	32,750	162				
90	53.6	28,200	121	90	60.8	27,280	156				
100	48.3	23,940	112	100	56.8	23,020	150				
110	42.5	20,510	102	110	52.7	19,580	143				
120	35.9	17,700	90	120	48.3	16,770	135				
130	28.0	15,350	73	130	43.6	14,430	125				
140	17.0	13,350	48	140	38.4	12,430	113				
				150	32.5	10,730	99				
				160	25.4	9,240	80				
				170	15.3	7,940	52				
150' Boom length				180' Boom length							
Radius (Feet)	Boom Angle (Degrees)	360 Degree Rating (Pounds)	From Boom Pt. to Ground (Feet)	Radius (Feet)	Boom Angle (Degrees)	360 Degree Rating (Pounds)	From Boom Pt. to Ground (Feet)				
26	82.7	171,730	157	29	83.0	143,810	187				
30	81.2	137,140	156	30	82.6	136,360	187				
35	79.2	108,910	155	35	81.0	108,080	186				
40	77.3	89,550	154	40	79.4	88,640	185				
50	73.3	65,320	152	50	76.2	64,380	183				
60	69.3	50,370	148	60	72.9	49,370	180				
70	65.2	40,320	144	70	69.5	39,660	177				
80	60.9	33,390	139	80	66.1	32,400	173				
90	56.4	27,940	133	90	62.5	26,940	168				
100	51.7	23,670	126	100	58.9	22,660	162				
110	46.6	20,260	117	110	55.1	19,230	156				
120	41.0	17,450	106	120	51.1	16,420	148				
130	34.7	15,100	93	130	46.8	14,070	139				
140	27.1	13,100	76	140	42.3	12,080	129				
150	16.4	11,380	50	150	37.2	10,370	117				
				160	31.5	8,880	102				
				170	24.6	7,590	82				
				180	14.9	6,430	54				
160' Boom length				190' Boom length							
Radius (Feet)	Boom Angle (Degrees)	360 Degree Rating (Pounds)	From Boom Pt. to Ground (Feet)	Radius (Feet)	Boom Angle (Degrees)	360 Degree Rating (Pounds)	From Boom Pt. to Ground (Feet)				
27	82.8	161,670	167	31	82.7	129,300	197				
30	81.7	136,880	166	35	81.5	107,800	196				
35	79.9	108,640	166	40	80.0	88,320	195				
40	78.1	89,260	165	50	76.9	64,050	193				
50	74.4	65,010	162	60	73.8	49,030	191				
60	70.7	50,040	159	70	70.7	39,340	187				
70	66.8	40,320	155	80	67.4	32,070	183				
80	62.9	33,070	150	90	64.1	26,590	179				
90	58.8	27,610	145	100	60.7	22,310	174				
100	54.5	23,350	138	110	57.2	18,890	168				
110	49.9	19,920	130	120	53.5	16,070	161				
120	45.0	17,110	121	130	49.6	13,720	153				
130	39.6	14,760	110	140	45.5	11,720	143				
140	33.5	12,770	96	150	41.1	10,010	133				
150	26.2	11,060	78	160	36.2	8,530	120				
160	15.8	9,570	51	170	30.6	7,220	104				
				180	23.9	6,080	85				
				190	14.4	5,070	55				



LOAD CHART

HC 165

With 77SI Hammerhead Tip Boom and 102,000 Pound Upper Counterweight

102,000 lb				360°				ANSI B 30.5							
200' Boom length				220' Boom length				210' Boom length				230' Boom length			
Radius (Feet)	Boom Angle (Degrees)	360 Degree Rating (Pounds)	From Boom Pt. to Ground (Feet)	Radius (Feet)	Boom Angle (Degrees)	360 Degree Rating (Pounds)	From Boom Pt. to Ground (Feet)	Radius (Feet)	Boom Angle (Degrees)	360 Degree Rating (Pounds)	From Boom Pt. to Ground (Feet)	Radius (Feet)	Boom Angle (Degrees)	360 Degree Rating (Pounds)	From Boom Pt. to Ground (Feet)
32	82.8	122,830	207	34	82.9	102,110*	226	33	82.9	112,450*	216	35	83.0	96,610*	236
35	81.9	107,530	206	35	82.7	101,710*	226	35	82.3	107,240	216	40	81.7	87,080	236
40	80.5	88,030	205	40	81.4	87,400	226	40	80.9	87,720	215	50	79.2	62,770	234
50	77.6	63,760	203	50	78.7	63,100	224	50	78.2	63,430	214	60	76.7	47,670	232
60	74.6	48,720	201	60	76.1	48,020	222	60	75.4	48,360	211	70	74.1	38,020	229
70	71.7	39,050	198	70	73.4	38,370	219	70	72.6	38,700	208	80	71.5	30,720	226
80	68.6	31,760	194	80	70.6	31,070	216	80	69.7	31,420	205	90	68.9	25,220	223
90	65.5	26,280	190	90	67.8	25,580	212	90	66.7	25,930	201	100	66.2	20,920	218
100	62.3	22,010	185	100	65.0	21,290	207	100	63.7	21,650	196	110	63.4	17,480	214
110	59.0	18,570	179	110	62.1	17,840	202	110	60.6	18,210	191	120	60.6	14,650	208
120	55.6	15,750	173	120	59.1	15,030	197	120	57.5	15,390	185	130	57.7	12,300	202
130	52.0	13,400	166	130	56.0	12,670	190	130	54.1	13,030	178	140	54.7	10,290	196
140	48.3	11,410	157	140	52.8	10,670	183	140	50.7	11,040	170	150	51.5	8,580	188
150	44.3	9,690	147	150	49.4	8,960	175	150	47.0	9,320	162	160	48.3	7,090	179
160	40.0	8,210	136	160	45.9	7,470	166	160	43.2	7,830	151	170	44.8	5,780	170
170	35.2	6,910	123	170	42.1	6,160	155	170	39.0	6,540	140	180	41.1	4,640	159
180	29.8	5,770	107	180	38.0	5,020	143	180	34.3	5,390	126	190	37.2	3,620	147
190	23.3	4,750	87	190	33.5	4,010	129	190	29.1	4,370	110				
200	14.1	3,850	56	200	28.4	3,100	112	200	22.7	3,460	89				
240' Boom length															
37	82.8	84,390*	246												
40	82.1	84,000*	246												
50	79.7	62,440	244												
60	77.2	47,310	242												
70	74.8	37,680	240												
80	72.3	30,360	237												
90	69.8	24,860	233												
100	67.2	20,560	229												
110	64.6	17,110	225												
120	61.9	14,280	220												
130	59.2	11,920	214												
140	56.3	9,920	208												
150	53.4	8,200	201												
160	50.4	6,710	193												
170	47.2	5,410	184												
180	43.8	4,260	174												
190	40.2	3,240	163												

LOAD CHART

HC 165

With 77SI Hammerhead Tip Boom and 116,400 Pound Counterweight

108,400 lb + 8,000 lb carbody counterweight				360°	ANSI B 30.5
50' Boom length					
Radius (Feet)	Boom Angle (Degrees)	360 Degree Rating (Pounds)	From Boom Pt. to Ground (Feet)		
14	81.9	330,000*	58		
15	80.8	330,000*	57		
20	75.0	285,140	56		
25	68.9	193,760	55		
30	62.7	145,760	52		
35	55.9	116,200	49		
40	48.5	96,080	45		
50	29.5	70,550	32		
60' Boom length					
Radius (Feet)	Boom Angle (Degrees)	360 Degree Rating (Pounds)	From Boom Pt. to Ground (Feet)		
15	82.3	330,000*	68		
20	77.5	285,570	67		
25	72.6	194,080	65		
30	67.5	145,990	63		
35	62.2	116,410	61		
40	56.6	96,260	58		
50	44.0	70,760	49		
60	26.7	55,120	35		
70' Boom length					
Radius (Feet)	Boom Angle (Degrees)	360 Degree Rating (Pounds)	From Boom Pt. to Ground (Feet)		
16	82.6	330,000*	78		
20	79.3	285,800	77		
25	75.1	194,230	76		
30	70.8	146,080	74		
35	66.5	116,490	72		
40	61.9	96,310	70		
50	52.0	70,820	63		
60	40.5	55,190	53		
70	24.6	44,650	37		
80' Boom length					
Radius (Feet)	Boom Angle (Degrees)	360 Degree Rating (Pounds)	From Boom Pt. to Ground (Feet)		
17	82.8	330,000*	87		
20	80.6	285,890	87		
25	77.0	194,240	86		
30	73.3	146,050	85		
35	69.6	116,420	83		
40	65.7	96,230	81		
50	57.5	70,730	75		
60	48.4	55,100	68		
70	37.7	44,570	57		
80	22.9	37,050	39		
90' Boom length					
Radius (Feet)	Boom Angle (Degrees)	360 Degree Rating (Pounds)	From Boom Pt. to Ground (Feet)		
18	82.9	330,000*	97		
20	81.7	285,910	97		
25	78.5	194,190	96		
30	75.2	145,960	95		
35	71.9	116,320	94		
40	68.5	96,090	92		
50	61.5	70,590	87		
60	53.9	54,950	81		
70	45.4	44,430	72		
80	35.4	36,960	60		
90	21.5	31,200	40		
100' Boom length					
Radius (Feet)	Boom Angle (Degrees)	360 Degree Rating (Pounds)	From Boom Pt. to Ground (Feet)		
20	82.5	285,920	107		
25	79.6	194,160	106		
30	76.7	145,880	105		
35	73.8	116,230	104		
40	70.8	95,990	102		
50	64.6	70,490	98		
60	58.0	54,840	93		
70	50.9	44,310	85		
80	43.0	36,890	76		
90	33.5	31,150	63		
100	20.3	26,640	42		
110' Boom length					
Radius (Feet)	Boom Angle (Degrees)	360 Degree Rating (Pounds)	From Boom Pt. to Ground (Feet)		
21	82.7	261,440	117		
25	80.6	194,020	117		
30	77.9	145,710	116		
35	75.3	116,040	114		
40	72.6	95,760	113		
50	67.0	70,260	109		
60	61.2	54,590	104		
70	55.0	44,050	98		
80	48.3	36,660	90		
90	40.8	30,920	80		
100	31.8	26,430	66		
110	19.3	22,810	44		
120' Boom length					
Radius (Feet)	Boom Angle (Degrees)	360 Degree Rating (Pounds)	From Boom Pt. to Ground (Feet)		
22	82.8	240,680	127		
25	81.4	193,870	127		
30	78.9	145,510	126		
35	76.5	115,830	125		
40	74.1	95,530	123		
50	69.0	70,020	120		
60	63.8	54,330	116		
70	58.3	43,790	110		
80	52.5	36,420	103		
90	46.2	30,680	94		
100	39.0	26,190	83		
110	30.4	22,590	68		
120	18.4	19,610	45		
130' Boom length					
Radius (Feet)	Boom Angle (Degrees)	360 Degree Rating (Pounds)	From Boom Pt. to Ground (Feet)		
23	82.9	222,590	137		
25	82.0	193,690	137		
30	79.8	145,290	136		
35	77.6	115,590	135		
40	75.3	95,260	134		
50	70.7	69,740	131		
60	66.0	54,040	127		
70	61.0	43,470	122		
80	55.8	36,130	115		
90	50.3	30,400	108		
100	44.2	25,910	98		
110	37.4	22,310	87		
120	29.2	19,340	71		
130	17.6	16,860	47		



LOAD CHART

HC 165

With 77SI Hammerhead Tip Boom and 116,400 Pound Counterweight

108,400 lb + 8,000 lb carbody counterweight				360°	ANSI B 30.5
140' Boom length					
Radius (Feet)	Boom Angle (Degrees)	360 Degree Rating (Pounds)	From Boom Pt. to Ground (Feet)		
25	82.6	193,500	147		
30	80.5	145,050	146		
35	78.5	115,340	145		
40	76.4	94,980	144		
50	72.1	69,460	141		
60	67.8	53,740	138		
70	63.3	43,170	133		
80	58.6	35,840	127		
90	53.6	30,110	121		
100	48.3	25,630	112		
110	42.5	22,020	102		
120	35.9	19,060	90		
130	28.0	16,590	73		
140	17.0	14,480	48		
150' Boom length					
Radius (Feet)	Boom Angle (Degrees)	360 Degree Rating (Pounds)	From Boom Pt. to Ground (Feet)		
26	82.7	181,270	157		
30	81.2	144,850	156		
35	79.2	115,120	155		
40	77.3	94,740	154		
50	73.3	69,210	152		
60	69.3	53,480	148		
70	65.2	42,900	144		
80	60.9	35,600	139		
90	56.4	29,860	133		
100	51.7	25,370	126		
110	46.6	21,780	117		
120	41.0	18,810	106		
130	34.7	16,340	93		
140	27.1	14,240	76		
150	16.4	12,440	50		
160' Boom length					
Radius (Feet)	Boom Angle (Degrees)	360 Degree Rating (Pounds)	From Boom Pt. to Ground (Feet)		
27	82.8	170,310	167		
30	81.7	144,600	166		
35	79.9	114,850	166		
40	78.1	94,450	165		
50	74.4	68,910	162		
60	70.7	53,160	159		
70	66.8	42,570	155		
80	62.9	35,280	150		
90	58.8	29,530	145		
100	54.5	25,050	138		
110	49.9	21,440	130		
120	45.0	18,490	121		
130	39.6	16,010	110		
140	33.5	13,910	96		
150	26.2	12,120	78		
160	15.8	10,550	51		
170' Boom length					
Radius (Feet)	Boom Angle (Degrees)	360 Degree Rating (Pounds)	From Boom Pt. to Ground (Feet)		
28	82.9	160,840	177		
30	82.2	144,350	177		
35	80.5	114,590	176		
40	78.8	94,160	175		
50	75.4	68,600	173		
60	71.8	52,840	170		
70	68.3	42,230	166		
80	64.6	34,960	162		
90	60.8	29,210	156		
100	56.8	24,720	150		
110	52.7	21,110	143		
120	48.3	18,150	135		
130	43.6	15,690	125		
140	38.4	13,590	113		
150	32.5	11,790	99		
160	25.4	10,230	80		
170	15.3	8,860	52		
180' Boom length					
Radius (Feet)	Boom Angle (Degrees)	360 Degree Rating (Pounds)	From Boom Pt. to Ground (Feet)		
29	83.0	151,930	187		
30	82.6	144,080	187		
35	81.0	114,310	186		
40	79.4	93,850	185		
50	76.2	68,290	183		
60	72.9	52,500	180		
70	69.5	41,870	177		
80	66.1	34,620	173		
90	62.5	28,870	168		
100	58.9	24,380	162		
110	55.1	20,760	156		
120	51.1	17,800	148		
130	46.8	15,330	139		
140	42.3	13,240	129		
150	37.2	11,440	117		
160	31.5	9,880	102		
170	24.6	8,510	82		
180	14.9	7,300	54		
190' Boom length					
Radius (Feet)	Boom Angle (Degrees)	360 Degree Rating (Pounds)	From Boom Pt. to Ground (Feet)		
31	82.7	136,680	197		
35	81.5	114,030	196		
40	80.0	93,530	195		
50	76.9	67,970	193		
60	73.8	52,160	191		
70	70.7	41,530	187		
80	67.4	34,300	183		
90	64.1	28,530	179		
100	60.7	24,030	174		
110	57.2	20,430	168		
120	53.5	17,460	161		
130	49.6	14,990	153		
140	45.5	12,890	143		
150	41.1	11,090	133		
160	36.2	9,530	120		
170	30.6	8,160	104		
180	23.9	6,960	85		
190	14.4	5,890	55		

LOAD CHART

HC 165

With 77SI Hammerhead Tip Boom and 116,400 Pound Counterweight

108,400 lb + 8,000 lb carbody counterweight				360°				ANSI B 30.5			
200' Boom length				220' Boom length							
Radius (Feet)	Boom Angle (Degrees)	360 Degree Rating (Pounds)	From Boom Pt. to Ground (Feet)	Radius (Feet)	Boom Angle (Degrees)	360 Degree Rating (Pounds)	From Boom Pt. to Ground (Feet)				
32	82.8	126,040*	207	34	82.9	102,050*	226				
35	81.9	113,770	206	35	82.7	101,650*	226				
40	80.5	93,250	205	40	81.4	92,630	226				
50	77.6	67,690	203	50	78.7	67,030	224				
60	74.6	51,850	201	60	76.1	51,160	222				
70	71.7	41,220	198	70	73.4	40,500	219				
80	68.6	33,990	194	80	70.6	33,310	216				
90	65.5	28,230	190	90	67.8	27,530	212				
100	62.3	23,730	185	100	65.0	23,020	207				
110	59.0	20,120	179	110	62.1	19,400	202				
120	55.6	17,150	173	120	59.1	16,430	197				
130	52.0	14,680	166	130	56.0	13,950	190				
140	48.3	12,580	157	140	52.8	11,850	183				
150	44.3	10,770	147	150	49.4	10,050	175				
160	40.0	9,220	136	160	45.9	8,480	166				
170	35.2	7,850	123	170	42.1	7,110	155				
180	29.8	6,650	107	180	38.0	5,900	143				
190	23.3	5,580	87	190	33.5	4,840	129				
200	14.1	4,620	56	200	28.4	3,880	112				
				210	22.2	3,020	91				
210' Boom length				230' Boom length							
Radius (Feet)	Boom Angle (Degrees)	360 Degree Rating (Pounds)	From Boom Pt. to Ground (Feet)	Radius (Feet)	Boom Angle (Degrees)	360 Degree Rating (Pounds)	From Boom Pt. to Ground (Feet)				
33	82.9	112,390*	216	35	83.0	92,560*	236				
35	82.3	112,030*	216	40	81.7	92,150*	236				
40	80.9	92,940	215	50	79.2	66,710	234				
50	78.2	67,360	214	60	76.7	50,820	232				
60	75.4	51,510	211	70	74.1	40,130	229				
70	72.6	40,860	208	80	71.5	32,960	226				
80	69.7	33,660	205	90	68.9	27,180	223				
90	66.7	27,880	201	100	66.2	22,660	218				
100	63.7	23,370	196	110	63.4	19,030	214				
110	60.6	19,750	191	120	60.6	16,060	208				
120	57.5	16,790	185	130	57.7	13,580	202				
130	54.1	14,310	178	140	54.7	11,470	196				
140	50.7	12,210	170	150	51.5	9,670	188				
150	47.0	10,410	162	160	48.3	8,110	179				
160	43.2	8,840	151	170	44.8	6,730	170				
170	39.0	7,480	140	180	41.1	5,530	159				
180	34.3	6,270	126	190	37.2	4,460	147				
190	29.1	5,200	110	200	32.8	3,490	132				
200	22.7	4,240	89								
210	13.7	3,390	57								
240' Boom length											
Radius (Feet)	Boom Angle (Degrees)	360 Degree Rating (Pounds)	From Boom Pt. to Ground (Feet)								
37	82.8	84,340*	246								
40	82.1	83,950*	246								
50	79.7	66,380	244								
60	77.2	50,470	242								
70	74.8	40,310	240								
80	72.3	32,610	237								
90	69.8	26,820	233								
100	67.2	22,290	229								
110	64.6	18,670	225								
120	61.9	15,690	220								
130	59.2	13,210	214								
140	56.3	11,100	208								
150	53.4	9,300	201								
160	50.4	7,730	193								
170	47.2	6,360	184								
180	43.8	5,150	174								
190	40.2	4,080	163								
200	36.3	3,120	150								



Warning

This rating chart is invalid if the crane has been modified or altered by use of other than GENUINE AMERICAN PARTS as such modifications or alterations may affect its capacity or safe operation. See American Crane Corporation Service Bulliten #259.

Ratings in this chart are in POUNDS and do not exceed the percentage of tipping specified for this crane by ANSI B30.5. All ratings require that the crane be standing level on a firm uniformly supporting surface.

Do not lift loads in excess of those shown on this chart. Lifting loads in excess of those shown or operation not in accordance with good operating practice, including limitations shown on page 3499 of Operator's Manual, can cause tipping, structural damage or catastrophic failure.

Asterisk (*) areas on this chart indicate ratings which are limited by strength of material or factors other than stability (tipping).

„RADIUS IN FEET“ is the horizontal distance at ground level from the crane centerline of rotation to a vertical line through the center of gravity of the suspended load.

When using the main boom fall with jib in place, the main fall ratings must be reduced by the jib effective weight shown on the jib rating chart plus twice the weight of all suspended blocks, slings, rope, etc., at the jib fall. See Appendix A.

When using the main boom fall with boom tip extension in place, the main fall ratings must be reduced by the weight of the boom tip extension plus twice the weight of all suspended blocks, slings, rope, etc., at the boom tip extension fall. See Appendix A.

Blocks, slings, buckets and other load carrying devices are considered part of the load. The weight of standard hoisting ropes for the rating at a given radius has been calculated as part of the boom point load and need not be considered in determining net allowable loads. See Appendix A.

This chart was developed exclusively for use with a boom only. Under no circumstances are these ratings to be interpreted for use with a jib. Ratings shown on this chart make no allowance for such factors as out of plumb loads, wind, poor soil conditions, improper inflation of rubber tires and dynamic effects due to excessive operating speeds. The user (operator) must exercise judgement to make allowance for these conditions. See page 3499 of Operator's Manual for detailed information.

No account is taken of the wind force on the load. This effect, which can be substantial for loads with large surface areas, must be considered by the user. In any wind it is strongly recommended that taglines be used to control the load.

BOOM HOIST LINE is 14 parts of 7/8 inch diameter EIPS wire rope with a minimum breaking strength of 79,600 pound.

PENDANT SUSPENSION LINE is 4 parts of 1.375 inch diameter EEIPS wire rope with a minimum breaking strength of 211,000 pound.

MAIN LOAD LINE – 1.125 inch diameter EIPS wire rope with a minimum breaking strength of 130,000 pound.

ALTERNATE LOAD LINE (ROTATION RESISTANT) – 1.125 inch diameter BRIDON ENDURANCE DYFORM 34LR Grade 2160 wire rope with a minimum breaking strength of 167,200 pound.

ERECTION

Erection „OVER THE END“ is with the boom over the idler end with idler tumblers blocked (See operator's manual for blocking instructions). Erection „OVER THE SIDE“ is with the boom 90° to the sideframes and with the side frames extended. Blocks, slings and other load carrying devices must be on the ground during erection.

77SI HAMMERHEAD BOOM MAXIMUM BOOM & JIB SELF-ERECTION DATA				
	OVER THE END		OVER THE SIDE	
	BOOM LENGTH (FEET)	JIB LENGTH (FEET)	BOOM LENGTH (FEET)	JIB LENGTH (FEET)
#16HL JIB	240	0	220	0
	230	0	210	40
	220	80	200	80

LOAD HOISTING INFORMATION - 1.125 inch diameter EIPS wire rope			
MAXIMUM LIFTING CAPACITY - LBS.	MINIMUM PARTS OF LINE	MAXIMUM HOISTING DISTANCE - FEET	
		MAIN - (FRONT)	AUX. - (REAR)
330,000	9	145	145
297,120	8	164	164
259,980	7	187	187
222,840	6	218	218
185,700	5	262	262
148,560	4	328	328
111,420	3	437	437
74,280	2	656	656
37,140	1	1,312	1,312

LOAD HOISTING INFORMATION (ROTATION RESISTANT LOAD LINE) 1.125 inch diameter BRIDON ENDURANCE DYFORM 34LR Grade 2160 wire rope			
MAXIMUM LIFTING CAPACITY - LBS.	MINIMUM PARTS OF LINE	MAXIMUM HOISTING DISTANCE - FEET	
		MAIN - (FRONT)	AUX. - (REAR)
330,000	10	131	131
300,960	9	145	145
267,520	8	164	164
234,080	7	187	187
200,640	6	218	218
167,200	5	262	262
133,760	4	328	328
100,320	3	437	437
66,880	2	656	656
33,440	1	1,312	1,312

77SI HAMMERHEAD BOOM COMPOSITION CHART							
BOOM LENGTH (METERS)	BOOM LENGTH (FEET)	BOOM SECTIONS					
		9.1 M 30' 77SI INNER	3.0 M 10' 77S CENTER	6.1 M 20' 77S CENTER	15.2 M 50' 77S CENTER	5.9 M 19.5' 77HL OUTER	0 M 0' HAMMER HEAD
15.2 M	50	1	0	0	0	1	1
18.3 M	60	1	1	0	0	1	1
21.3 M	70	1	0	1	0	1	1
24.4 M	80	1	1	1	0	1	1
27.4 M	90	1	0	2	0	1	1
30.5 M	100	1	0	0	1	1	1
33.5 M	110	1	1	0	1	1	1
36.6 M	120	1	0	1	1	1	1
39.6 M	130	1	1	1	1	1	1
42.7 M	140	1	0	2	1	1	1
45.7 M	150	1	0	0	2	1	1
48.8 M	160	1	1	0	2	1	1
51.8 M	170	1	0	1	2	1	1
54.9 M	180	1	1	1	2	1	1
57.9 M	190	1	0	2	2	1	1
61.0 M	200	1	0	0	3	1	1
64.0 M	210	1	1	1	0	3	1
67.1 M	220	1	0	1	3	1	1
70.1 M	230	1	1	1	3	1	1
73.2 M	240	1	0	2	3	1	1

RANGE DIAGRAM

HC 165

77SI Offset Tip Boom

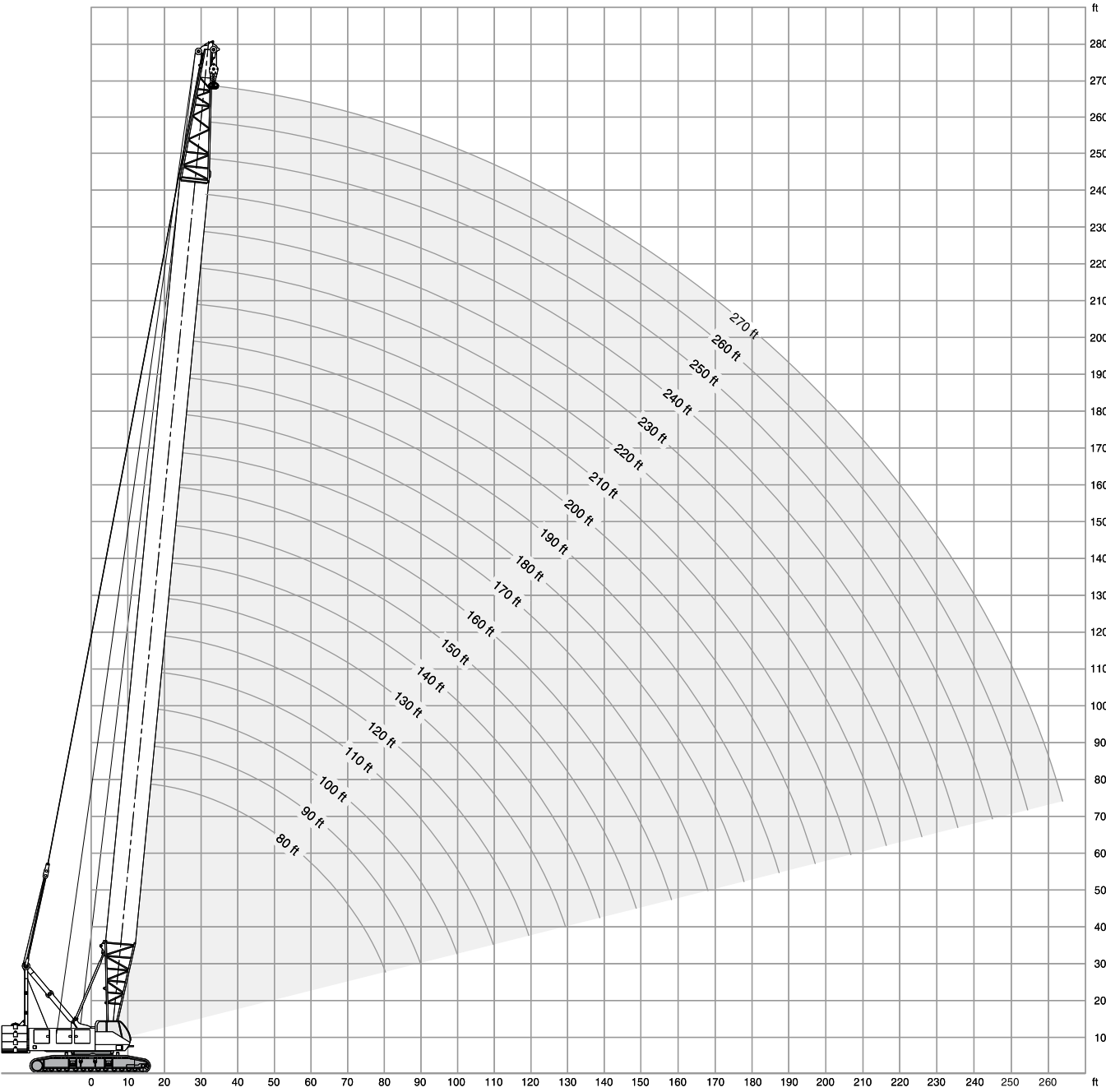

LOAD CHART

HC 165

With 77SI Offset Tip Boom and 102,000 Pound Upper Counterweight

102,000 lb				360°				ANSI B 30.5			
80' Boom length				120' Boom length							
Radius (Feet)	Boom Angle (Degrees)	360 Degree Rating (Pounds)	From Boom Pt. to Ground (Feet)	Radius (Feet)	Boom Angle (Degrees)	360 Degree Rating (Pounds)	From Boom Pt. to Ground (Feet)				
17	81.0	235,130*	86	24	80.6	196,990	125				
20	78.8	235,130*	86	25	80.1	184,190	125				
25	75.1	184,750	84	30	77.7	138,670	124				
30	71.4	139,390	83	35	75.2	110,750	123				
35	67.5	111,510	81	40	72.8	91,640	122				
40	63.6	92,490	79	50	67.7	67,650	118				
50	55.3	68,510	73	60	62.4	52,890	113				
60	46.0	53,820	65	70	56.9	42,970	108				
70	35.0	43,940	53	80	51.0	36,050	100				
80	19.2	36,910	33	90	44.5	30,660	91				
				100	37.2	26,460	80				
				110	28.4	23,090	64				
				120	15.6	20,330	39				
90' Boom length				130' Boom length							
Radius (Feet)	Boom Angle (Degrees)	360 Degree Rating (Pounds)	From Boom Pt. to Ground (Feet)	Radius (Feet)	Boom Angle (Degrees)	360 Degree Rating (Pounds)	From Boom Pt. to Ground (Feet)				
19	80.7	234,610*	96	25	80.9	184,010	135				
20	80.0	230,880*	96	30	78.7	138,480	135				
25	76.8	184,680	95	35	76.4	110,550	133				
30	73.5	139,270	93	40	74.1	91,420	132				
35	70.1	111,380	92	50	69.5	67,430	129				
40	66.7	92,330	90	60	64.7	52,660	125				
50	59.6	68,350	85	70	59.7	42,730	119				
60	51.9	53,640	78	80	54.5	35,840	113				
70	43.2	43,750	69	90	48.8	30,450	105				
80	32.9	36,750	56	100	42.7	26,250	95				
90	18.0	31,380	35	110	35.7	22,870	83				
100' Boom length				140' Boom length							
Radius (Feet)	Boom Angle (Degrees)	360 Degree Rating (Pounds)	From Boom Pt. to Ground (Feet)	Radius (Feet)	Boom Angle (Degrees)	360 Degree Rating (Pounds)	From Boom Pt. to Ground (Feet)				
21	80.5	221,940*	106	27	80.7	162,360	145				
25	78.1	184,560	105	30	79.5	138,200	145				
30	75.2	139,120	104	35	77.4	110,270	144				
35	72.2	111,220	102	40	75.3	91,110	143				
40	69.2	92,150	101	50	71.0	67,120	139				
50	62.9	68,150	96	60	66.6	52,340	136				
60	56.2	53,430	90	70	62.1	42,400	131				
70	49.0	43,530	83	80	57.3	35,540	125				
80	40.9	36,570	73	90	52.3	30,140	118				
90	31.2	31,180	59	100	47.0	25,930	109				
100	17.1	26,980	37	110	41.1	22,560	99				
110' Boom length				150' Boom length							
Radius (Feet)	Boom Angle (Degrees)	360 Degree Rating (Pounds)	From Boom Pt. to Ground (Feet)	Radius (Feet)	Boom Angle (Degrees)	360 Degree Rating (Pounds)	From Boom Pt. to Ground (Feet)				
22	80.8	213,950*	116	28	81.0	153,400	155				
25	79.2	184,380	115	30	80.2	137,920	155				
30	76.6	138,910	114	35	78.2	109,970	154				
35	73.9	110,990	113	40	76.3	90,810	153				
40	71.1	91,900	111	50	72.3	66,810	150				
50	65.5	67,910	107	60	68.3	52,020	146				
60	59.7	53,160	102	70	64.1	42,070	142				
70	53.4	43,260	95	80	59.7	35,220	137				
80	46.6	36,310	87	90	55.2	29,820	130				
90	38.9	30,930	76	100	50.4	25,610	123				
100	29.7	26,720	62	110	45.3	22,230	114				
110	16.3	23,360	38	120	39.6	19,470	103				
				130	33.2	17,160	89				
				140	25.3	15,200	71				
				150	14.0	13,530	43				

LOAD CHART

HC 165

With 77SI Offset Tip Boom and 102,000 Pound Upper Counterweight

102,000 lb				360°				ANSI B 30.5			
160' Boom length				190' Boom length							
Radius (Feet)	Boom Angle (Degrees)	360 Degree Rating (Pounds)	From Boom Pt. to Ground (Feet)	Radius (Feet)	Boom Angle (Degrees)	360 Degree Rating (Pounds)	From Boom Pt. to Ground (Feet)				
30	80.8	137,620	165	35	80.7	108,760	195				
35	79.0	109,670	164	40	79.2	89,520	194				
40	77.2	90,480	163	50	76.1	65,520	192				
50	73.4	66,480	160	60	73.0	50,660	189				
60	69.7	51,680	157	70	69.8	40,670	185				
70	65.8	41,720	153	80	66.6	33,900	181				
80	61.8	34,880	148	90	63.2	28,490	177				
90	57.7	29,490	142	100	59.8	24,280	171				
100	53.3	25,270	135	110	56.3	20,880	165				
110	48.7	21,890	127	120	52.5	18,110	158				
120	43.8	19,120	118	130	48.6	15,790	150				
130	38.3	16,810	106	140	44.5	13,830	140				
140	32.1	14,840	92	150	40.0	12,150	129				
150	24.5	13,180	74	160	35.0	10,690	116				
160	13.5	11,720	44	170	29.4	9,410	100				
				180	22.5	8,300	80				
				190	12.4	7,330	48				
170' Boom length				200' Boom length							
Radius (Feet)	Boom Angle (Degrees)	360 Degree Rating (Pounds)	From Boom Pt. to Ground (Feet)	Radius (Feet)	Boom Angle (Degrees)	360 Degree Rating (Pounds)	From Boom Pt. to Ground (Feet)				
32	80.7	124,500	175	36	80.9	104,020	205				
35	79.6	109,360	174	40	79.8	89,170	204				
40	77.9	90,150	173	50	76.8	65,180	202				
50	74.4	66,150	171	60	73.9	50,310	199				
60	70.9	51,330	168	70	70.9	40,310	196				
70	67.3	41,360	164	80	67.8	33,560	192				
80	63.6	34,560	159	90	64.7	28,150	188				
90	59.8	29,150	154	100	61.5	23,920	183				
100	55.8	24,930	148	110	58.1	20,520	177				
110	51.6	21,550	140	120	54.7	17,750	170				
120	47.2	18,780	132	130	51.1	15,430	163				
130	42.4	16,460	122	140	47.3	13,470	154				
140	37.1	14,500	110	150	43.3	11,780	144				
150	31.1	12,830	95	160	38.9	10,320	133				
160	23.8	11,370	76	170	34.1	9,050	119				
170	13.1	10,110	46	180	28.6	7,930	103				
				190	21.9	6,940	82				
				200	12.1	6,060	49				
180' Boom length				210' Boom length							
Radius (Feet)	Boom Angle (Degrees)	360 Degree Rating (Pounds)	From Boom Pt. to Ground (Feet)	Radius (Feet)	Boom Angle (Degrees)	360 Degree Rating (Pounds)	From Boom Pt. to Ground (Feet)				
33	80.9	119,010	185	38	80.8	95,740	214				
35	80.2	109,080	184	40	80.3	88,820	214				
40	78.6	89,860	184	50	77.5	64,820	212				
50	75.3	65,860	181	60	74.7	49,940	210				
60	72.0	51,030	178	70	71.8	40,390	207				
70	68.6	41,040	175	80	68.9	33,190	203				
80	65.2	34,260	170	90	65.9	27,770	199				
90	61.6	28,850	165	100	62.9	23,540	194				
100	57.9	24,630	160	110	59.8	20,160	189				
110	54.1	21,250	153	120	56.6	17,370	182				
120	50.0	18,470	145	130	53.3	15,050	175				
130	45.8	16,160	136	140	49.8	13,090	167				
140	41.1	14,190	126	150	46.1	11,400	158				
150	36.0	12,510	113	160	42.2	9,940	148				
160	30.2	11,060	98	170	38.0	8,660	136				
170	23.1	9,800	78	180	33.3	7,530	122				
180	12.7	8,690	47	190	27.9	6,540	105				
				200	21.4	5,660	84				
				210	11.8	4,880	50				



LOAD CHART

HC 165

With 77SI Offset Tip Boom and 102,000 Pound Upper Counterweight

102,000 lb				360°				ANSI B 30.5			
220' Boom length				250' Boom length							
Radius (Feet)	Boom Angle (Degrees)	360 Degree Rating (Pounds)	From Boom Pt. to Ground (Feet)	Radius (Feet)	Boom Angle (Degrees)	360 Degree Rating (Pounds)	From Boom Pt. to Ground (Feet)				
39	81.0	91,810	224	44	80.9	74,200*	254				
40	80.7	88,470	224	50	79.5	63,430	253				
50	78.1	64,470	222	60	77.2	48,490	251				
60	75.4	49,570	220	70	74.8	39,010	248				
70	72.7	40,040	217	80	72.4	31,780	245				
80	69.9	32,840	214	90	70.0	26,340	242				
90	67.1	27,420	210	100	67.5	22,100	238				
100	64.2	23,180	205	110	65.0	18,690	234				
110	61.3	19,790	200	120	62.5	15,900	229				
120	58.3	17,000	194	130	59.8	13,580	223				
130	55.2	14,680	188	140	57.2	11,600	217				
140	52.0	12,710	180	150	54.4	9,920	210				
150	48.6	11,030	172	160	51.5	8,440	203				
160	45.0	9,560	163	170	48.5	7,160	194				
170	41.2	8,280	152	180	45.4	6,040	185				
180	37.1	7,150	140	190	42.1	5,030	175				
190	32.5	6,160	125	200	38.5	4,140	163				
200	27.3	5,270	108	210	34.7	3,330	149				
210	20.9	4,480	85	220	30.4	2,610	134				
220	11.5	3,780	51								
230' Boom length				260' Boom length							
Radius (Feet)	Boom Angle (Degrees)	360 Degree Rating (Pounds)	From Boom Pt. to Ground (Feet)	Radius (Feet)	Boom Angle (Degrees)	360 Degree Rating (Pounds)	From Boom Pt. to Ground (Feet)				
41	80.8	85,000	234	46	80.8	68,160*	264				
50	78.6	64,140	233	50	79.9	63,560	263				
60	76.0	49,230	230	60	77.7	48,610	261				
70	73.4	39,720	228	70	75.4	39,130	259				
80	70.8	32,510	224	80	73.1	31,910	256				
90	68.2	27,080	221	90	70.8	26,460	253				
100	65.4	22,850	216	100	68.4	22,220	249				
110	62.7	19,450	211	110	66.0	18,810	245				
120	59.8	16,670	206	120	63.6	16,020	240				
130	56.9	14,340	200	130	61.1	13,680	235				
140	53.9	12,370	193	140	58.6	11,710	229				
150	50.7	10,690	185	150	56.0	10,020	223				
160	47.4	9,220	177	160	53.3	8,540	215				
170	44.0	7,940	167	170	50.5	7,260	208				
180	40.2	6,810	156	180	47.5	6,130	199				
190	36.2	5,810	143	190	44.5	5,130	189				
200	31.7	4,920	128	200	41.2	4,230	178				
210	26.6	4,120	110	210	37.7	3,420	166				
220	20.4	3,410	87	220	34.0	2,700	152				
230	11.3	2,790	52								
240' Boom length				270' Boom length							
Radius (Feet)	Boom Angle (Degrees)	360 Degree Rating (Pounds)	From Boom Pt. to Ground (Feet)	Radius (Feet)	Boom Angle (Degrees)	360 Degree Rating (Pounds)	From Boom Pt. to Ground (Feet)				
42	81.0	81,680	244	47	80.9	62,440*	274				
50	79.1	63,790	243	50	80.3	61,770*	273				
60	76.6	48,860	241	60	78.1	48,230	271				
70	74.1	39,360	238	70	75.9	38,770	269				
80	71.7	32,150	235	80	73.8	31,540	266				
90	69.1	26,710	231	90	71.5	26,090	263				
100	66.5	22,480	227	100	69.3	21,840	260				
110	63.9	19,070	223	110	67.0	18,430	256				
120	61.2	16,280	217	120	64.7	15,630	251				
130	58.5	13,950	212	130	62.3	13,290	246				
140	55.6	11,990	205	140	59.9	11,330	241				
150	52.7	10,300	198	150	57.4	9,630	235				
160	49.6	8,830	190	160	54.8	8,160	228				
170	46.4	7,550	181	170	52.2	6,870	220				
180	43.0	6,420	171	180	49.4	5,740	212				
190	39.4	5,420	159	190	46.6	4,730	203				
200	35.4	4,530	146	200	43.6	3,840	193				
210	31.1	3,720	131	210	40.4	3,030	182				
220	26.1	3,000	113								

LOAD CHART

HC 165

With 77SI Offset Tip Boom and 116,400 Pound Counterweight

108,400 lb + 8,000 lb carbody counterweight				360°				ANSI B 30.5			
80' Boom length				120' Boom length							
Radius (Feet)	Boom Angle (Degrees)	360 Degree Rating (Pounds)	From Boom Pt. to Ground (Feet)	Radius (Feet)	Boom Angle (Degrees)	360 Degree Rating (Pounds)	From Boom Pt. to Ground (Feet)				
17	81.0	235,130*	86	24	80.6	201,030*	125				
20	78.8	235,130*	86	25	80.1	194,570	125				
25	75.1	195,140	84	30	77.7	146,580	124				
30	71.4	147,300	83	35	75.2	117,140	123				
35	67.5	117,910	81	40	72.8	97,000	122				
40	63.6	97,850	79	50	67.7	71,700	118				
50	55.3	72,560	73	60	62.4	56,150	113				
60	46.0	57,080	65	70	56.9	45,700	108				
70	35.0	46,660	53	80	51.0	38,390	100				
80	19.1	39,250	33	90	44.5	32,720	91				
				100	37.2	28,290	80				
				110	28.4	24,740	64				
				120	15.6	21,830	39				
90' Boom length				130' Boom length							
19	80.7	234,610*	96	25	80.9	192,950*	135				
20	80.0	230,880*	96	30	78.7	146,390	135				
25	76.8	195,060	95	35	76.4	116,940	133				
30	73.5	147,180	93	40	74.1	96,780	132				
35	70.1	117,770	92	50	69.5	71,480	129				
40	66.7	97,690	90	60	64.7	55,920	125				
50	59.6	72,410	85	70	59.7	45,460	119				
60	51.9	56,900	78	80	54.5	38,180	113				
70	43.2	46,470	69	90	48.8	32,500	105				
80	32.9	39,100	56	100	42.7	28,080	95				
90	18.0	33,430	35	110	35.7	24,520	83				
				120	27.3	21,600	67				
				130	15.0	19,170	41				
100' Boom length				140' Boom length							
21	80.5	221,940*	106	27	80.7	171,590	145				
25	78.1	194,940	105	30	79.5	146,110	145				
30	75.2	147,040	104	35	77.4	116,660	144				
35	72.2	117,610	102	40	75.3	96,470	143				
40	69.2	97,510	101	50	71.0	71,180	139				
50	62.9	72,210	96	60	66.6	55,600	136				
60	56.2	56,690	90	70	62.1	45,130	131				
70	49.0	46,260	83	80	57.3	37,880	125				
80	40.9	38,910	73	90	52.3	32,190	118				
90	31.2	33,240	59	100	47.0	27,760	109				
100	17.1	28,810	37	110	41.1	24,200	99				
				120	34.4	21,290	86				
				130	26.2	18,850	69				
				140	14.4	16,800	42				
110' Boom length				150' Boom length							
22	80.8	213,950*	116	28	81.0	161,800	155				
25	79.2	194,760	115	30	80.2	145,830	155				
30	76.6	146,820	114	35	78.2	116,360	154				
35	73.9	117,380	113	40	76.3	96,170	153				
40	71.1	97,260	111	50	72.3	70,870	150				
50	65.5	71,960	107	60	68.3	55,280	146				
60	59.7	56,420	102	70	64.1	44,800	142				
70	53.4	45,980	95	80	59.7	37,570	137				
80	46.6	38,650	87	90	55.2	31,880	130				
90	38.9	32,980	76	100	50.4	27,440	123				
100	29.7	28,550	62	110	45.3	23,880	114				
110	16.3	25,000	38	120	39.6	20,970	103				
				130	33.2	18,530	89				
				140	25.3	16,470	71				
				150	14.0	14,710	43				



LOAD CHART

HC 165

With 77SI Offset Tip Boom and 116,400 Pound Counterweight

108,400 lb + 8,000 lb carbody counterweight				360°				ANSI B 30.5			
160' Boom length				190' Boom length							
Radius (Feet)	Boom Angle (Degrees)	360 Degree Rating (Pounds)	From Boom Pt. to Ground (Feet)	Radius (Feet)	Boom Angle (Degrees)	360 Degree Rating (Pounds)	From Boom Pt. to Ground (Feet)	Radius (Feet)	Boom Angle (Degrees)	360 Degree Rating (Pounds)	From Boom Pt. to Ground (Feet)
30	80.8	145,530	165	35	80.7	115,150	195				
35	79.0	116,060	164	40	79.2	94,880	194				
40	77.2	95,840	163	50	76.1	69,580	192				
50	73.4	70,540	160	60	73.0	53,930	189				
60	69.7	54,940	157	70	69.8	43,400	185				
70	65.8	44,450	153	80	66.6	36,250	181				
80	61.8	37,230	148	90	63.2	30,540	177				
90	57.7	31,540	142	100	59.8	26,100	171				
100	53.3	27,100	135	110	56.3	22,530	165				
110	48.7	23,540	127	120	52.5	19,610	158				
120	43.8	20,610	118	130	48.6	17,170	150				
130	38.3	18,180	106	140	44.5	15,100	140				
140	32.1	16,110	92	150	40.0	13,330	129				
150	24.5	14,350	74	160	35.0	11,790	116				
160	13.5	12,830	44	170	29.4	10,440	100				
				180	22.5	9,270	80				
				190	12.4	8,240	48				
170' Boom length				200' Boom length							
32	80.7	131,730	175	36	80.9	110,170	205				
35	79.6	115,750	174	40	79.8	94,530	204				
40	77.9	95,510	173	50	76.8	69,230	202				
50	74.4	70,210	171	60	73.9	53,570	199				
60	70.9	54,590	168	70	70.9	43,030	196				
70	67.3	44,080	164	80	67.8	35,900	192				
80	63.6	36,900	159	90	64.7	30,200	188				
90	59.8	31,200	154	100	61.5	25,750	183				
100	55.8	26,760	148	110	58.1	22,170	177				
110	51.6	23,200	140	120	54.7	19,250	170				
120	47.2	20,270	132	130	51.1	16,810	163				
130	42.4	17,830	122	140	47.3	14,740	154				
140	37.1	15,770	110	150	43.3	12,960	144				
150	31.1	14,000	95	160	38.9	11,430	133				
160	23.8	12,470	76	170	34.1	10,080	119				
170	13.1	11,140	46	180	28.6	8,900	103				
				190	21.9	7,860	82				
				200	12.1	6,930	49				
180' Boom length				210' Boom length							
33	80.9	125,530	185	38	80.8	101,470	214				
35	80.2	115,470	184	40	80.3	94,180	214				
40	78.6	95,220	184	50	77.5	68,880	212				
50	75.3	69,910	181	60	74.7	53,200	210				
60	72.0	54,290	178	70	71.8	42,650	207				
70	68.6	43,770	175	80	68.9	35,540	203				
80	65.2	36,600	170	90	65.9	29,830	199				
90	61.6	30,900	165	100	62.9	25,370	194				
100	57.9	26,460	160	110	59.8	21,800	189				
110	54.1	22,900	153	120	56.6	18,870	182				
120	50.0	19,970	145	130	53.3	16,430	175				
130	45.8	17,530	136	140	49.8	14,360	167				
140	41.1	15,460	126	150	46.1	12,580	158				
150	36.0	13,690	113	160	42.2	11,040	148				
160	30.2	12,160	98	170	38.0	9,690	136				
170	23.1	10,830	78	180	33.3	8,510	122				
180	12.7	9,660	47	190	27.9	7,460	105				
				200	21.4	6,530	84				
				210	11.8	5,710	50				

LOAD CHART

HC 165

With 77SI Offset Tip Boom and 116,400 Pound Counterweight

108,400 lb + 8,000 lb carbody counterweight				360°	ANSI B 30.5		
220' Boom length				250' Boom length			
Radius (Feet)	Boom Angle (Degrees)	360 Degree Rating (Pounds)	From Boom Pt. to Ground (Feet)	Radius (Feet)	Boom Angle (Degrees)	360 Degree Rating (Pounds)	From Boom Pt. to Ground (Feet)
39	81.0	97,360	224	44	80.9	74,200 *	254
40	80.7	93,830	224	50	79.5	67,490	253
50	78.1	68,520	222	60	77.2	51,750	251
60	75.4	52,830	220	70	74.8	41,170	248
70	72.7	42,290	217	80	72.4	34,120	245
80	69.9	35,180	214	90	70.0	28,400	242
90	67.1	29,470	210	100	67.5	23,930	238
100	64.2	25,010	205	110	65.0	20,340	234
110	61.3	21,430	200	120	62.5	17,400	229
120	58.3	18,500	194	130	59.8	14,960	223
130	55.2	16,050	188	140	57.2	12,870	217
140	52.0	13,980	180	150	54.4	11,100	210
150	48.6	12,210	172	160	51.5	9,540	203
160	45.0	10,660	163	170	48.5	8,190	194
170	41.2	9,310	152	180	45.4	7,010	185
180	37.1	8,130	140	190	42.1	5,950	175
190	32.5	7,080	125	200	38.5	5,010	163
200	27.3	6,140	108	210	34.7	4,160	149
210	20.9	5,310	85	220	30.4	3,400	134
220	11.5	4,570	51	230	25.5	2,710	115
230' Boom length				260' Boom length			
Radius (Feet)	Boom Angle (Degrees)	360 Degree Rating (Pounds)	From Boom Pt. to Ground (Feet)	Radius (Feet)	Boom Angle (Degrees)	360 Degree Rating (Pounds)	From Boom Pt. to Ground (Feet)
41	80.8	90,190	234	46	80.8	68,160 *	264
50	78.6	68,190	233	50	79.9	67,250 *	263
60	76.0	52,490	230	60	77.7	51,870	261
70	73.4	41,940	228	70	75.4	41,280	259
80	70.8	34,850	224	80	73.1	34,250	256
90	68.2	29,130	221	90	70.8	28,520	253
100	65.4	24,670	216	100	68.4	24,050	249
110	62.7	21,090	211	110	66.0	20,460	245
120	59.8	18,170	206	120	63.6	17,510	240
130	56.9	15,710	200	130	61.1	15,060	235
140	53.9	13,640	193	140	58.6	12,980	229
150	50.7	11,870	185	150	56.0	11,200	223
160	47.4	10,320	177	160	53.3	9,640	215
170	44.0	8,970	167	170	50.5	8,290	208
180	40.2	7,780	156	180	47.5	7,100	199
190	36.2	6,730	143	190	44.5	6,050	189
200	31.7	5,790	128	200	41.2	5,100	178
210	26.6	4,950	110	210	37.7	4,250	166
220	20.4	4,200	87	220	34.0	3,490	152
230	11.3	3,540	52	230	29.8	2,800	136
240' Boom length				270' Boom length			
Radius (Feet)	Boom Angle (Degrees)	360 Degree Rating (Pounds)	From Boom Pt. to Ground (Feet)	Radius (Feet)	Boom Angle (Degrees)	360 Degree Rating (Pounds)	From Boom Pt. to Ground (Feet)
42	81.0	83,410 *	244	47	80.9	62,440 *	274
50	79.1	67,840	243	50	80.3	61,770 *	273
60	76.6	52,120	241	60	78.1	51,490	271
70	74.1	41,550	238	70	75.9	40,890	269
80	71.7	34,490	235	80	73.8	33,880	266
90	69.1	28,770	231	90	71.5	28,140	263
100	66.5	24,300	227	100	69.3	23,660	260
110	63.9	20,720	223	110	67.0	20,070	256
120	61.2	17,780	217	120	64.7	17,130	251
130	58.5	15,330	212	130	62.3	14,670	246
140	55.6	13,260	205	140	59.9	12,600	241
150	52.7	11,480	198	150	57.4	10,810	235
160	49.6	9,930	190	160	54.8	9,260	228
170	46.4	8,590	181	170	52.2	7,900	220
180	43.0	7,390	171	180	49.4	6,710	212
190	39.4	6,340	159	190	46.6	5,650	203
200	35.4	5,400	146	200	43.6	4,710	193
210	31.1	4,550	131	210	40.4	3,850	182
220	26.1	3,790	113	220	37.0	3,090	170
230	20.0	3,110	89				

Warning

This rating chart is invalid if the crane has been modified or altered by use of other than GENUINE AMERICAN PARTS as such modifications or alterations may affect its capacity or safe operation. See American Crane Corporation Service Bulliten #259.

Ratings in this chart are in POUNDS and do not exceed the percentage of tipping specified for this crane by ANSI B30.5. All ratings require that the crane be standing level on a firm uniformly supporting surface.

Do not lift loads in excess of those shown on this chart. Lifting loads in excess of those shown or operation not in accordance with good operating practice, including limitations shown on page 3499 of Operator's Manual, can cause tipping, structural damage or catastrophic failure.

Asterisk (*) areas on this chart indicate ratings which are limited by strength of material or factors other than stability (tipping).

„RADIUS IN FEET“ is the horizontal distance at ground level from the crane centerline of rotation to a vertical line through the center of gravity of the suspended load.

When using the main boom fall with jib in place, the main fall ratings must be reduced by the jib effective weight shown on the jib rating chart plus twice the weight of all suspended blocks, slings, rope, etc., at the jib fall. See Appendix A.

When using the main boom fall with boom tip extension in place, the main fall ratings must be reduced by the weight of the boom tip extension plus twice the weight of all suspended blocks, slings, rope, etc., at the boom tip extension fall. See Appendix A.

Blocks, slings, buckets and other load carrying devices are considered part of the load. The weight of standard hoisting ropes for the rating at a given radius has been calculated as part of the boom point load and need not be considered in determining net allowable loads. See Appendix A.

This chart was developed exclusively for use with a boom only. Under no circumstances are these ratings to be interpreted for use with a jib. Ratings shown on this chart make no allowance for such factors as out of plumb loads, wind, poor soil conditions, improper inflation of rubber tires and dynamic effects due to excessive operating speeds. The user (operator) must exercise judgement to make allowance for these conditions. See page 3499 of Operator's Manual for detailed information.

No account is taken of the wind force on the load. This effect, which can be substantial for loads with large surface areas, must be considered by the user. In any wind it is strongly recommended that taglines be used to control the load.

MAST HOIST LINE is 14 parts of 7/8 inch diameter EIPS wire rope with a minimum breaking strength of 79,600 pound.

PENDANT SUSPENSION LINE is 4 parts of 1.375 inch diameter MONOLAY wire rope with a minimum breaking strength of 208,000 pound.

MAIN LOAD LINE – 1.125 inch diameter EIPS wire rope with a minimum breaking strength of 130,000 pound.

ALTERNATE LOAD LINE (ROTATION RESISTANT) – 1.125 inch diameter BRIDON ENDURANCE DYFORM 34LR Grade 2160 wire rope with a minimum breaking strength of 167,200 pound.

ERECTION

Erection „OVER THE END“ is with the boom over the idler end with idler tumblers blocked (See operator's manual for blocking instructions). Erection „OVER THE SIDE“ is with the boom 90° to the sideframes and with the side frames extended. Blocks, slings and other load carrying devices must be on the ground during erection.

77SI OFFSET TIP BOOM MAXIMUM BOOM & JIB SELF-ERECTION DATA				
	OVER THE END		OVER THE SIDE	
	BOOM LENGTH (FT)	JIB LENGTH (FT)	BOOM LENGTH (FT)	JIB LENGTH (FT)
#16HL JIB	270	0	240	0
	260	0	230	60
	250	60	220	80
	240	80		

LOAD HOISTING INFORMATION - 1.125 inch diameter EIPS wire rope			
MAXIMUM LIFTING CAPACITY - LBS.	MINIMUM PARTS OF LINE	MAXIMUM HOISTING DISTANCE - FEET	
		MAIN - (FRONT)	AUX. - (REAR)
235,130	7	187	187
222,840	6	218	218
185,700	5	262	262
148,560	4	328	328
111,420	3	437	437
74,280	2	656	656
37,140	1	1,312	1,312

LOAD HOISTING INFORMATION (ROTATION RESISTANT LOAD LINE) 1.125 inch diameter BRIDON ENDURANCE DYFORM 34LR Grade 2160 wire rope			
MAXIMUM LIFTING CAPACITY - LBS.	MINIMUM PARTS OF LINE	MAXIMUM HOISTING DISTANCE - FEET	
		MAIN - (FRONT)	AUX. - (REAR)
234,080	7	187	187
200,640	6	218	218
167,200	5	262	262
133,760	4	328	328
100,320	3	437	437
66,880	2	656	656
33,440	1	1,312	1,312

Note: The Single Sheave Boom Point Extension is required to reeve 7 parts of line. The weight of the Single Sheave Boom Point Extension is 590 Pounds.

77SI OFFSET TIP BOOM COMPOSITION CHART							
BOOM LENGTH (METERS)	BOOM LENGTH (FEET)	BOOM SECTIONS					
		9.1 M 30' 77SI INNER	3.0 M 10' 77S CENTER	6.1 M 20' 77S CENTER	15.2 M 50' 77S CENTER	5.9 M 19.5' 77HL OUTER	9.1 M 30' 77LA OFFSET TIP
24.4 M	80	1	0	0	0	1	1
27.4 M	90	1	1	0	0	1	1
30.5 M	100	1	0	1	0	1	1
33.5 M	110	1	1	1	0	1	1
36.6 M	120	1	0	2	0	1	1
39.6 M	130	1	0	0	1	1	1
42.7 M	140	1	1	0	1	1	1
45.7 M	150	1	0	1	1	1	1
48.8 M	160	1	1	1	1	1	1
51.8 M	170	1	0	2	1	1	1
54.9 M	180	1	0	0	2	1	1
57.9 M	190	1	1	0	2	1	1
61.0 M	200	1	0	1	2	1	1
64.0 M	210	1	1	1	2	1	1
67.1 M	220	1	0	2	2	1	1
70.1 M	230	1	0	0	3	1	1
73.2 M	240	1	1	0	3	1	1
76.2 M	250	1	0	1	3	1	1
79.2 M	260	1	1	1	3	1	1
82.3 M	270	1	0	2	3	1	1

RANGE DIAGRAM

HC 165

77SI Hammerhead Tip Boom, #16HL Jib

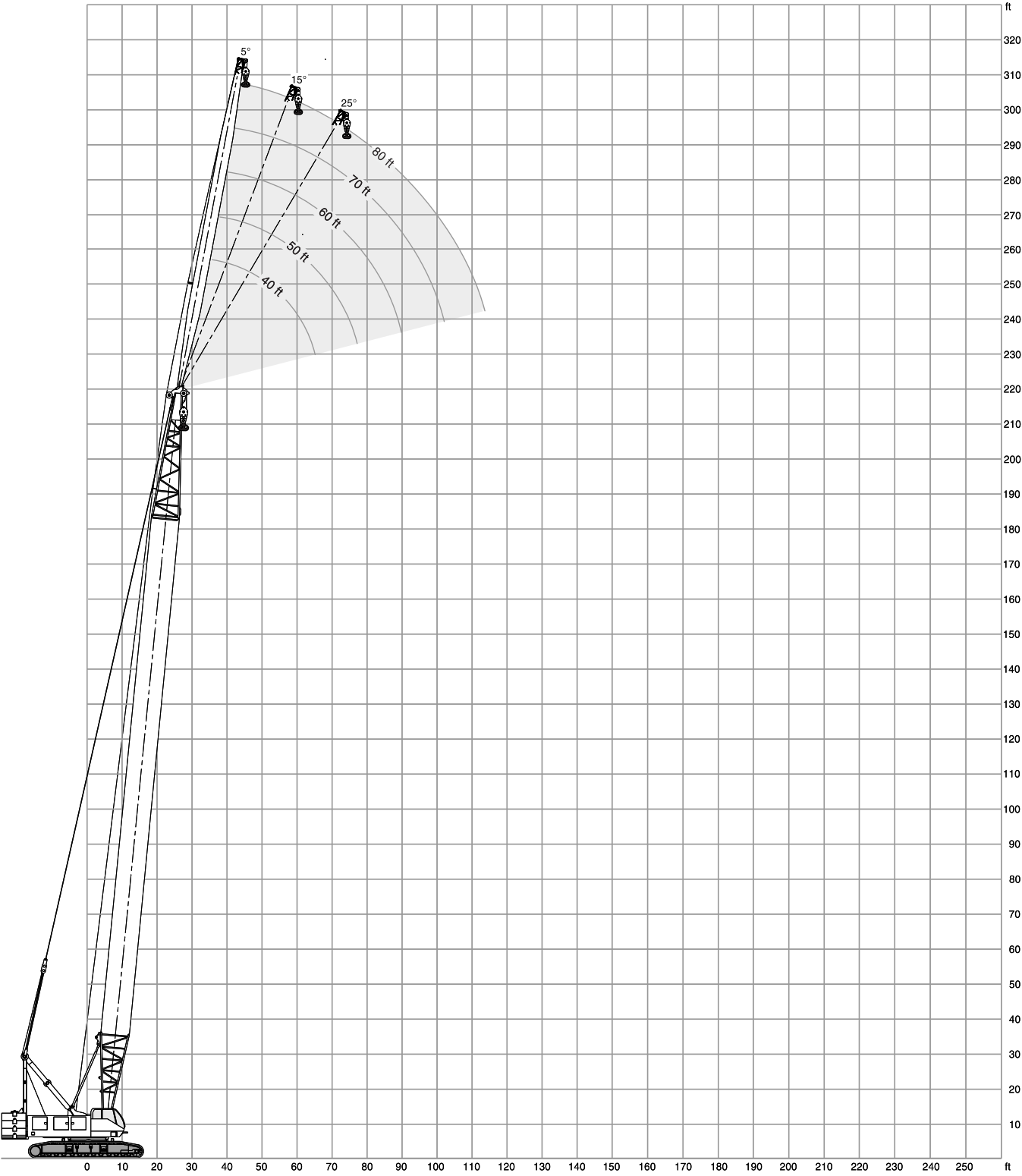

LOAD CHART

HC 165

With 77SI Hammerhead Tip Boom and 102,000 Pound Upper Counterweight #16HL Jib

102,000 lb				360°				ANSI B 30.5							
40' Jib length															
Boom length	Jib Radius (Feet)	5.0 Deg offset Boom Angle	32,000* Rating (Pounds)	15.0 Deg offset Boom Angle	32,000* Rating (Pounds)	25.0 Deg offset Boom Angle	32,000* Rating (Pounds)	Boom length	Jib Radius (Feet)	5.0 Deg offset Boom Angle	32,000* Rating (Pounds)	15.0 Deg offset Boom Angle	32,000* Rating (Pounds)	25.0 Deg offset Boom Angle	32,000* Rating (Pounds)
100'	26	82.8	32,000*	-	-	-	-	140'	31	82.8	32,000*	-	-	-	-
	30	81.2	32,000*	-	-	-	-		35	81.5	32,000*	-	-	-	-
	35	79.1	32,000*	81.8	32,000*	-	-		40	79.9	32,000*	82.0	32,000*	-	-
	40	77.0	32,000*	79.7	32,000*	82.3	32,000*		50	76.7	32,000*	78.8	32,000*	80.8	32,000*
	50	72.8	32,000*	75.5	32,000*	78.0	31,870*		60	73.4	32,000*	75.5	32,000*	77.4	31,230*
	60	68.5	32,000*	71.2	32,000*	73.6	28,630*		70	70.1	32,000*	72.2	32,000*	74.1	28,760*
	70	64.1	32,000*	66.7	31,970*	69.1	25,980*		80	66.7	32,000*	68.7	32,000*	70.6	26,630*
	80	59.4	32,000*	62.0	28,980*	64.3	23,890*		90	63.2	28,700	65.2	28,710	67.0	24,870*
	90	54.6	30,460	57.1	26,510*	59.3	22,270*		100	59.6	24,510	61.6	24,520	63.3	23,370*
	100	49.3	26,280	51.8	24,550*	53.9	20,840*		110	55.8	21,150	57.8	21,160	59.5	21,170
110'	27	82.9	32,000*	-	-	-	-	150'	32	82.9	32,000*	-	-	-	-
	30	81.7	32,000*	-	-	-	-		35	82.0	32,000*	-	-	-	-
	35	79.8	32,000*	82.4	32,000*	-	-		40	80.5	32,000*	82.5	32,000*	-	-
	40	77.9	32,000*	80.4	32,000*	82.8	32,000*		50	77.4	32,000*	79.4	32,000*	81.3	32,000*
	50	74.0	32,000*	76.5	32,000*	78.9	32,000*		60	74.3	32,000*	76.3	32,000*	78.1	31,780*
	60	70.0	32,000*	72.5	32,000*	74.8	29,370*		70	71.2	32,000*	73.1	32,000*	74.9	29,350*
	70	65.9	32,000*	68.4	32,000*	70.6	26,830*		80	68.0	32,000*	69.9	32,000*	71.7	27,250*
	80	61.7	32,000*	64.1	30,190*	66.3	24,630*		90	64.7	28,310	66.6	28,320	68.3	25,450*
	90	57.2	30,010	59.6	27,680*	61.7	22,970*		100	61.3	24,120	63.2	24,120	64.9	23,970*
	100	52.6	25,830	54.9	25,620*	56.9	21,490*		110	57.8	20,760	59.7	20,760	61.3	20,770
110	47.5	22,480	49.8	22,490	51.7	20,330*	120	54.2	18,010	56.0	18,010	57.6	18,030		
120'	28	83.0	32,000*	-	-	-	-	160'	33	82.9	32,000*	-	-	-	-
	30	82.3	32,000*	-	-	-	-		35	82.4	32,000*	-	-	-	-
	35	80.5	32,000*	82.8	32,000*	-	-		40	80.9	32,000*	82.8	32,000*	-	-
	40	78.7	32,000*	81.0	32,000*	-	-		50	78.0	32,000*	79.9	32,000*	81.7	32,000*
	50	75.0	32,000*	77.4	32,000*	79.6	32,000*		60	75.1	32,000*	77.0	32,000*	78.8	32,000*
	60	71.3	32,000*	73.6	32,000*	75.8	30,060*		70	72.1	32,000*	74.0	32,000*	75.7	29,780*
	70	67.5	32,000*	69.8	32,000*	71.9	27,510*		80	69.1	32,000*	71.0	32,000*	72.7	27,800*
	80	63.6	32,000*	65.9	31,210*	67.9	25,410*		90	66.0	27,870	67.9	27,880	69.5	26,000*
	90	59.5	29,580	61.8	28,740*	63.8	23,590*		100	62.9	23,670	64.7	23,680	66.3	23,690
	100	55.3	25,390	57.5	25,400	59.4	22,190*		110	59.6	20,310	61.4	20,320	63.0	20,330
110	50.8	22,050	52.9	22,060	54.8	20,950*	120	56.2	17,560	58.0	17,570	59.5	17,580		
120	45.9	19,300	48.1	19,310	49.8	19,320	130	52.7	15,280	54.4	15,280	55.9	15,290		
130'	30	82.7	32,000*	-	-	-	-	160'	140	49.0	13,340	50.7	13,340	52.1	13,350
	35	81.0	32,000*	-	-	-	-		150	45.1	11,690	46.7	11,700	48.1	11,710
	40	79.3	32,000*	81.6	32,000*	-	-		160	40.8	10,260	42.4	10,270	43.7	10,280
	50	75.9	32,000*	78.1	32,000*	80.2	32,000*								
	60	72.4	32,000*	74.6	32,000*	76.7	30,720*								
	70	68.9	32,000*	71.1	32,000*	73.1	28,150*								
	80	65.2	32,000*	67.4	32,000*	69.3	26,040*								
	90	61.5	29,140	63.6	29,140	65.5	24,230*								
	100	57.6	24,950	59.7	24,950	61.5	22,810*								
	110	53.5	21,590	55.5	21,600	57.3	21,540*								
120	49.1	18,850	51.2	18,860	52.8	18,870									
130	44.5	16,580	46.5	16,580	48.0	16,590									

LOAD CHART

HC 165

With 77SI Hammerhead Tip Boom and 102,000 Pound Upper Counterweight #16HL Jib

102,000 lb				360°				ANSI B 30.5							
40' Jib length															
Boom length	Jib Radius (Feet)	5.0 Deg offset Boom Angle	Rating (Pounds)	15.0 Deg offset Boom Angle	Rating (Pounds)	25.0 Deg offset Boom Angle	Rating (Pounds)	Boom length	Jib Radius (Feet)	5.0 Deg offset Boom Angle	Rating (Pounds)	15.0 Deg offset Boom Angle	Rating (Pounds)	25.0 Deg offset Boom Angle	Rating (Pounds)
170'	34	83.0	32,000*	-	-	-	-	200'	38	82.9	32,000*	-	-	-	-
	35	82.7	32,000*	-	-	-	-		40	82.4	32,000*	-	-	-	-
	40	81.4	32,000*	-	-	-	-		50	80.0	32,000*	81.6	32,000*	-	-
	50	78.6	32,000*	80.4	32,000*	82.1	32,000*		60	77.6	32,000*	79.2	32,000*	80.7	32,000*
	60	75.8	32,000*	77.6	32,000*	79.3	32,000*		70	75.2	32,000*	76.7	32,000*	78.2	31,590*
	70	73.0	32,000*	74.8	32,000*	76.4	30,390*		80	72.7	31,570	74.3	31,580	75.7	29,630*
	80	70.2	32,000*	71.9	32,000*	73.5	28,310*		90	70.2	26,180	71.7	26,180	73.2	26,190
	90	67.2	27,440	69.0	27,440	70.6	26,500*		100	67.7	21,970	69.2	21,970	70.6	21,980
	100	64.3	23,240	66.0	23,250	67.5	23,260		110	65.1	18,600	66.6	18,600	67.9	18,610
	110	61.2	19,880	62.9	19,880	64.4	19,890		120	62.4	15,830	63.9	15,840	65.2	15,850
	120	58.0	17,120	59.7	17,130	61.2	17,140		130	59.7	13,530	61.2	13,530	62.5	13,540
	130	54.8	14,840	56.4	14,840	57.9	14,850		140	56.9	11,590	58.3	11,590	59.6	11,610
	140	51.3	12,890	53.0	12,900	54.4	12,910		150	54.0	9,920	55.4	9,930	56.6	9,940
	150	47.7	11,230	49.3	11,240	50.7	11,250		160	50.9	8,490	52.4	8,490	53.6	8,510
160	43.9	9,810	45.5	9,820	46.7	9,830	170	47.8	7,240	49.2	7,250	50.3	7,260		
170	39.8	8,570	41.3	8,570	42.5	8,590	180	44.5	6,140	45.8	6,140	46.9	6,160		
							190	40.9	5,170	42.3	5,180	43.3	5,190		
							200	37.1	4,310	38.4	4,320	39.3	4,330		
180'	36	82.8	32,000*	-	-	-	-	210'	39	83.0	32,000*	-	-	-	-
	40	81.8	32,000*	-	-	-	-		40	82.7	32,000*	-	-	-	-
	50	79.1	32,000*	80.9	32,000*	82.5	32,000*		50	80.4	32,000*	82.0	32,000*	-	-
	60	76.5	32,000*	78.2	32,000*	79.8	32,000*		60	78.1	32,000*	79.6	32,000*	81.1	32,000*
	70	73.8	32,000*	75.5	32,000*	77.1	30,810*		70	75.8	32,000*	77.3	32,000*	78.7	31,970*
	80	71.1	32,000*	72.8	32,000*	74.3	28,800*		80	73.4	31,140	74.9	31,150	76.3	30,080*
	90	68.3	27,010	70.0	27,010	71.5	27,010*		90	71.0	25,740	72.5	25,740	73.9	25,750
	100	65.5	22,800	67.2	22,800	68.7	22,810		100	68.6	21,530	70.1	21,530	71.4	21,540
	110	62.6	19,430	64.3	19,440	65.7	19,450		110	66.1	18,160	67.6	18,160	68.9	18,170
	120	59.6	16,680	61.3	16,680	62.7	16,700		120	63.6	15,390	65.0	15,390	66.3	15,400
	130	56.6	14,380	58.2	14,390	59.6	14,400		130	61.0	13,080	62.4	13,090	63.7	13,100
	140	53.4	12,440	55.0	12,450	56.3	12,460		140	58.4	11,140	59.8	11,150	61.0	11,160
	150	50.1	10,780	51.6	10,790	52.9	10,800		150	55.6	9,470	57.0	9,480	58.2	9,490
	160	46.6	9,340	48.1	9,350	49.3	9,360		160	52.8	8,040	54.2	8,040	55.3	8,060
170	42.8	8,100	44.3	8,110	45.5	8,120	170	49.8	6,780	51.2	6,780	52.3	6,800		
180	38.8	7,010	40.3	7,020	41.3	7,030	180	46.8	5,680	48.1	5,690	49.2	5,700		
							190	43.5	4,710	44.8	4,720	45.8	4,730		
							200	40.0	3,840	41.3	3,850	42.3	3,860		
							210	36.3	3,070	37.5	3,080	38.4	3,100		
190'	37	82.9	32,000*	-	-	-	-	220'	41	82.8	32,000*	-	-	-	-
	40	82.1	32,000*	-	-	-	-		50	80.8	32,000*	82.3	32,000*	-	-
	50	79.6	32,000*	81.3	32,000*	82.8	32,000*		60	78.6	32,000*	80.0	32,000*	81.4	32,000*
	60	77.1	32,000*	78.7	32,000*	80.3	32,000*		70	76.3	32,000*	77.8	32,000*	79.1	32,000*
	70	74.5	32,000*	76.2	32,000*	77.7	31,190*		80	74.1	30,720	75.5	30,730	76.8	30,360*
	80	71.9	31,970	73.6	31,980	75.0	29,180*		90	71.8	25,320	73.2	25,320	74.5	25,330
	90	69.3	26,570	70.9	26,570	72.4	26,580		100	69.4	21,090	70.9	21,100	72.2	21,110
	100	66.6	22,370	68.2	22,370	69.7	22,380		110	67.1	17,720	68.5	17,730	69.8	17,740
	110	63.9	19,000	65.5	19,000	66.9	19,020		120	64.7	14,960	66.1	14,960	67.3	14,970
	120	61.1	16,240	62.7	16,240	64.0	16,250		130	62.2	12,650	63.6	12,660	64.8	12,670
	130	58.2	13,940	59.8	13,950	61.1	13,960		140	59.7	10,700	61.1	10,700	62.3	10,710
	140	55.2	12,000	56.8	12,000	58.1	12,010		150	57.1	9,040	58.5	9,040	59.6	9,050
	150	52.1	10,330	53.6	10,340	54.9	10,350		160	54.4	7,590	55.8	7,600	56.9	7,610
	160	48.9	8,900	50.4	8,910	51.6	8,920		170	51.7	6,340	53.0	6,340	54.1	6,350
170	45.5	7,650	46.9	7,650	48.1	7,670	180	48.8	5,230	50.1	5,230	51.2	5,250		
180	41.8	6,560	43.3	6,560	44.3	6,580	190	45.8	4,250	47.1	4,260	48.1	4,270		
190	37.9	5,590	39.3	5,600	40.3	5,620	200	42.6	3,390	43.9	3,400	44.8	3,410		
							210	39.2	2,620	40.5	2,620	41.3	2,640		



LOAD CHART

HC 165

With 77SI Hammerhead Tip Boom and 102,000 Pound Upper Counterweight #16HL Jib

102,000 lb				360°				ANSI B 30.5							
50' Jib length															
Boom length	Jib Radius (Feet)	5.0 Deg offset Boom Angle	5.0 Deg offset Rating (Pounds)	15.0 Deg offset Boom Angle	15.0 Deg offset Rating (Pounds)	25.0 Deg offset Boom Angle	25.0 Deg offset Rating (Pounds)	Boom length	Jib Radius (Feet)	5.0 Deg offset Boom Angle	5.0 Deg offset Rating (Pounds)	15.0 Deg offset Boom Angle	15.0 Deg offset Rating (Pounds)	25.0 Deg offset Boom Angle	25.0 Deg offset Rating (Pounds)
130'	32	82.7	32,000*	-	-	-	-	170'	37	82.8	32,000*	-	-	-	-
	35	81.8	32,000*	-	-	-	-		40	82.0	32,000*	-	-	-	-
	40	80.2	32,000*	82.8	29,160*	-	-		50	79.4	31,260*	81.5	28,440*	-	-
	50	77.0	30,720*	79.6	28,290*	82.1	26,260*		60	76.7	30,360*	78.9	27,790*	80.9	25,790*
	60	73.7	29,600*	76.3	27,380*	78.8	25,740*		70	74.0	29,380*	76.2	27,100*	78.2	25,270*
	70	70.4	28,580*	73.0	26,640*	75.4	23,910*		80	71.3	28,590*	73.4	26,460*	75.4	23,790*
	80	67.0	27,750*	69.5	25,930*	71.9	22,110*		90	68.5	27,710	70.7	25,870*	72.6	22,270*
	90	63.5	26,890*	66.0	25,320*	68.3	20,640*		100	65.7	23,510	67.8	23,510	69.7	20,980*
	100	59.8	25,230	62.3	23,620*	64.6	19,330*		110	62.8	20,140	64.9	20,150	66.8	19,840*
	110	56.1	21,880	58.5	21,890	60.7	18,220*		120	59.9	17,390	61.9	17,400	63.7	17,410
120	52.1	19,140	54.6	19,140	56.7	17,280*	130	56.8	15,100	58.8	15,110	60.6	15,120		
130	47.9	16,850	50.3	16,860	52.3	16,470*	140	53.6	13,150	55.6	13,160	57.3	13,170		
								150	50.3	11,500	52.3	11,510	53.9	11,520	
								160	46.8	10,070	48.7	10,070	50.3	10,090	
								170	43.1	8,820	44.9	8,830	46.4	8,850	
140'	33	82.8	32,000*	-	-	-	-	180'	38	82.8	32,000*	-	-	-	-
	35	82.2	32,000*	-	-	-	-		40	82.3	32,000*	-	-	-	-
	40	80.7	32,000*	-	-	-	-		50	79.8	31,420*	81.9	28,480*	-	-
	50	77.7	30,910*	80.2	28,390*	82.5	26,350*		60	77.3	30,430*	79.4	27,790*	81.3	25,770*
	60	74.6	29,810*	77.1	27,490*	79.4	25,740*		70	74.7	29,570*	76.8	27,210*	78.7	25,320*
	70	71.4	28,910*	73.9	26,760*	76.2	24,390*		80	72.2	28,720*	74.2	26,530*	76.1	24,160*
	80	68.2	27,980*	70.7	26,070*	72.9	22,570*		90	69.5	27,270	71.5	25,960*	73.4	22,620*
	90	65.0	27,100*	67.4	25,520*	69.6	21,030*		100	66.8	23,070	68.8	23,070	70.7	21,350*
	100	61.6	24,790	64.0	24,430*	66.1	19,800*		110	64.1	19,700	66.1	19,710	67.9	19,720
	110	58.1	21,440	60.4	21,440	62.5	18,650*		120	61.3	16,940	63.3	16,940	65.0	16,950
120	54.4	18,690	56.8	18,700	58.8	17,680*	130	58.4	14,640	60.4	14,650	62.1	14,660		
130	50.6	16,400	52.9	16,400	54.9	16,420	140	55.4	12,710	57.4	12,710	59.0	12,730		
140	46.6	14,470	48.8	14,480	50.7	14,490	150	52.3	11,040	54.2	11,050	55.8	11,060		
								160	49.1	9,610	51.0	9,620	52.5	9,630	
								170	45.7	8,360	47.5	8,360	49.0	8,380	
								180	42.1	7,270	43.8	7,270	45.2	7,290	
150'	34	82.9	32,000*	-	-	-	-	190'	39	82.9	32,000*	-	-	-	-
	35	82.6	32,000*	-	-	-	-		40	82.6	32,000*	-	-	-	-
	40	81.2	32,000*	-	-	-	-		50	80.2	31,420*	82.2	28,450*	-	-
	50	78.3	31,040*	80.7	28,390*	82.9	26,300*		60	77.8	30,490*	79.8	27,820*	81.7	25,700*
	60	75.4	30,100*	77.7	27,650*	79.9	25,720*		70	75.4	29,730*	77.4	27,200*	79.2	25,270*
	70	72.4	29,120*	74.7	26,880*	76.9	24,760*		80	72.9	28,960*	74.9	26,580*	76.7	24,420*
	80	69.4	28,170*	71.7	26,230*	73.8	23,020*		90	70.4	26,840	72.3	26,140*	74.1	22,960*
	90	66.3	27,360*	68.6	25,670*	70.7	21,480*		100	67.9	22,630	69.8	22,630	71.5	21,700*
	100	63.1	24,390	65.4	24,400	67.5	20,170*		110	65.3	19,260	67.2	19,260	68.9	19,280
	110	59.9	21,030	62.1	21,040	64.1	19,080*		120	62.6	16,500	64.5	16,510	66.2	16,520
120	56.5	18,280	58.7	18,290	60.7	18,110*	130	59.9	14,200	61.8	14,210	63.4	14,220		
130	52.9	16,000	55.1	16,000	57.0	16,020	140	57.1	12,260	58.9	12,270	60.5	12,280		
140	49.2	14,060	51.4	14,060	53.2	14,080	150	54.2	10,590	56.0	10,600	57.6	10,610		
150	45.3	12,410	47.4	12,420	49.1	12,430	160	51.1	9,160	53.0	9,170	54.5	9,180		
								170	48.0	7,900	49.8	7,910	51.2	7,920	
								180	44.7	6,810	46.4	6,810	47.8	6,830	
								190	41.1	5,840	42.8	5,850	44.1	5,870	
160'	35	83.0	32,000*	-	-	-	-								
	40	81.6	32,000*	-	-	-	-								
	50	78.8	31,280*	81.1	28,400*	-	-								
	60	76.1	30,170*	78.3	27,660*	80.4	25,790*								
	70	73.3	29,310*	75.5	26,990*	77.6	25,220*								
	80	70.4	28,440*	72.6	26,390*	74.7	23,380*								
	90	67.5	27,570*	69.7	25,780*	71.7	21,890*								
	100	64.5	23,950	66.7	23,960	68.6	20,590*								
	110	61.4	20,590	63.6	20,590	65.5	19,440*								
	120	58.3	17,830	60.4	17,840	62.3	17,850								
130	55.0	15,540	57.1	15,540	58.9	15,560									
140	51.6	13,600	53.6	13,610	55.4	13,620									
150	48.0	11,940	50.0	11,950	51.7	11,970									
160	44.1	10,520	46.1	10,530	47.7	10,550									

LOAD CHART

HC 165

With 77SI Hammerhead Tip Boom and 102,000 Pound Upper Counterweight #16HL Jib

102,000 lb **360°** **ANSI B 30.5**

50' Jib length							
Boom length	Jib Radius (Feet)	5.0 Deg offset Boom Angle	5.0 Deg offset Rating (Pounds)	15.0 Deg offset Boom Angle	15.0 Deg offset Rating (Pounds)	25.0 Deg offset Boom Angle	25.0 Deg offset Rating (Pounds)
	40	82.9	32,000*	-	-	-	-
	50	80.6	31,490*	82.6	28,430*	-	-
	60	78.3	30,650*	80.2	27,740*	82.0	25,590*
	70	76.0	29,740*	77.9	27,200*	79.6	25,280*
	80	73.6	28,970*	75.5	26,660*	77.2	24,770*
	90	71.2	26,440	73.1	26,110*	74.8	23,300*
	100	68.8	22,230	70.6	22,230	72.3	22,030*
	110	66.3	18,850	68.1	18,850	69.8	18,860
200'	120	63.8	16,090	65.6	16,100	67.2	16,110
	130	61.2	13,780	63.0	13,790	64.6	13,800
	140	58.5	11,840	60.3	11,850	61.9	11,860
	150	55.8	10,170	57.6	10,180	59.1	10,190
	160	53.0	8,740	54.7	8,750	56.2	8,760
	170	50.0	7,490	51.8	7,490	53.2	7,510
	180	47.0	6,380	48.7	6,390	50.0	6,400
	190	43.7	5,410	45.4	5,420	46.7	5,430
	200	40.2	4,550	41.9	4,560	43.1	4,580

	41	83.0	32,000*	-	-	-	-
	50	81.0	31,500*	82.8	28,400*	-	-
	60	78.8	30,600*	80.6	27,790*	82.3	25,550*
	70	76.5	29,840*	78.3	27,210*	80.1	25,240*
	80	74.3	29,130*	76.1	26,700*	77.8	24,840*
	90	72.0	26,000	73.8	26,000	75.4	23,620*
	100	69.6	21,790	71.4	21,790	73.1	21,800
	110	67.3	18,400	69.0	18,410	70.7	18,420
210'	120	64.9	15,650	66.6	15,650	68.2	15,670
	130	62.4	13,340	64.1	13,350	65.7	13,360
	140	59.9	11,400	61.6	11,400	63.1	11,420
	150	57.3	9,730	59.0	9,730	60.5	9,750
	160	54.6	8,280	56.3	8,290	57.8	8,300
	170	51.9	7,030	53.5	7,030	54.9	7,050
	180	49.0	5,930	50.6	5,930	52.0	5,950
	190	46.0	4,950	47.6	4,960	48.9	4,970
	200	42.8	4,080	44.4	4,090	45.6	4,110
	210	39.4	3,320	41.0	3,320	42.1	3,340

Boom length	Jib Radius (Feet)	5.0 Deg offset Boom Angle	5.0 Deg offset Rating (Pounds)	15.0 Deg offset Boom Angle	15.0 Deg offset Rating (Pounds)	25.0 Deg offset Boom Angle	25.0 Deg offset Rating (Pounds)
	43	82.8	31,940*	-	-	-	-
	50	81.3	31,460*	-	-	-	-
	60	79.2	30,670*	81.0	27,710*	82.6	25,550*
	70	77.0	29,960*	78.8	27,210*	80.4	25,190*
	80	74.9	29,130*	76.6	26,670*	78.2	24,850*
	90	72.7	25,570	74.4	25,570	76.0	23,920*
	100	70.4	21,360	72.1	21,360	73.7	21,370
	110	68.2	17,970	69.9	17,980	71.4	17,990
220'	120	65.9	15,200	67.6	15,210	69.1	15,220
	130	63.5	12,900	65.2	12,900	66.7	12,920
	140	61.1	10,950	62.8	10,960	64.3	10,970
	150	58.7	9,280	60.3	9,290	61.8	9,300
	160	56.1	7,840	57.8	7,850	59.2	7,860
	170	53.5	6,580	55.1	6,580	56.5	6,600
	180	50.8	5,470	52.4	5,480	53.8	5,500
	190	48.0	4,500	49.6	4,500	50.9	4,520
	200	45.1	3,630	46.6	3,640	47.8	3,660
	210	42.0	2,850	43.5	2,860	44.6	2,880
	220	38.6	2,160	40.1	2,170	41.2	2,190

60' Jib length							
Boom length	Jib Radius (Feet)	5.0 Deg offset Boom Angle	5.0 Deg offset Rating (Pounds)	15.0 Deg offset Boom Angle	15.0 Deg offset Rating (Pounds)	25.0 Deg offset Boom Angle	25.0 Deg offset Rating (Pounds)
	36	82.9	29,770*	-	-	-	-
	40	81.8	29,310*	-	-	-	-
	50	79.1	28,220*	81.8	25,520*	-	-
	60	76.3	27,180*	79.0	24,720*	81.6	22,840*
	70	73.5	26,280*	76.2	24,030*	78.7	21,700*
	80	70.6	25,330*	73.3	23,420*	75.8	20,160*
150'	90	67.7	24,620*	70.4	22,760*	72.8	18,790*
	100	64.7	23,870*	67.4	21,930*	69.8	17,610*
	110	61.7	21,280	64.3	20,460*	66.6	16,620*
	120	58.5	18,520	61.1	18,530	63.4	15,760*
	130	55.2	16,240	57.8	16,240	60.0	14,980*
	140	51.8	14,300	54.3	14,310	56.5	14,320*
	150	48.2	12,650	50.7	12,650	52.8	12,670

Boom length	Jib Radius (Feet)	5.0 Deg offset Boom Angle	5.0 Deg offset Rating (Pounds)	15.0 Deg offset Boom Angle	15.0 Deg offset Rating (Pounds)	25.0 Deg offset Boom Angle	25.0 Deg offset Rating (Pounds)
	37	83.0	29,690*	-	-	-	-
	40	82.2	29,360*	-	-	-	-
	50	79.6	28,350*	82.2	25,540*	-	-
	60	76.9	27,370*	79.5	24,810*	82.0	22,840*
	70	74.3	26,400*	76.8	24,090*	79.3	21,990*
	80	71.5	25,570*	74.1	23,480*	76.5	20,460*
160'	90	68.8	24,750*	71.3	22,950*	73.7	19,100*
	100	65.9	24,040*	68.5	22,400*	70.8	17,910*
	110	63.1	20,830	65.6	20,840	67.8	16,930*
	120	60.1	18,080	62.6	18,090	64.8	16,090*
	130	57.0	15,780	59.5	15,790	61.6	15,330*
	140	53.8	13,840	56.3	13,850	58.4	13,870
	150	50.5	12,190	52.9	12,200	54.9	12,220
	160	47.0	10,760	49.3	10,760	51.3	10,780



LOAD CHART

HC 165

With 77SI Hammerhead Tip Boom and 102,000 Pound Upper Counterweight #16HL Jib

102,000 lb				360°				ANSI B 30.5							
60' Jib length															
Boom length	Jib Radius (Feet)	5.0 Deg offset Boom Angle	5.0 Deg offset Rating (Pounds)	15.0 Deg offset Boom Angle	15.0 Deg offset Rating (Pounds)	25.0 Deg offset Boom Angle	25.0 Deg offset Rating (Pounds)	Boom length	Jib Radius (Feet)	5.0 Deg offset Boom Angle	5.0 Deg offset Rating (Pounds)	15.0 Deg offset Boom Angle	15.0 Deg offset Rating (Pounds)	25.0 Deg offset Boom Angle	25.0 Deg offset Rating (Pounds)
	39	82.8	29,570*	-	-	-	-								
	40	82.5	29,440*	-	-	-	-		42	83.0	29,210*	-	-	-	-
	50	80.0	28,370*	82.5	25,520*	-	-		50	81.2	28,530*	-	-	-	-
	60	77.5	27,510*	80.0	24,800*	82.3	22,770*		60	79.0	27,680*	81.2	24,820*	-	-
	70	75.0	26,630*	77.4	24,150*	79.7	22,200*		70	76.7	26,860*	78.9	24,260*	81.0	22,250*
	80	72.4	25,710*	74.8	23,540*	77.1	20,670*		80	74.4	26,170*	76.6	23,730*	78.7	21,470*
	90	69.7	24,980*	72.2	22,990*	74.4	19,390*		90	72.2	25,450*	74.3	23,220*	76.3	20,170*
	100	67.1	23,760	69.5	22,480*	71.7	18,230*		100	69.8	22,470	72.0	22,470	74.0	19,000*
	110	64.3	20,390	66.7	20,400	68.9	17,210*		110	67.5	19,090	69.6	19,100	71.5	18,040*
	120	61.5	17,640	63.9	17,640	66.0	16,350*		120	65.1	16,330	67.2	16,330	69.1	16,350
	130	58.6	15,340	61.0	15,350	63.1	15,370		130	62.6	14,030	64.7	14,040	66.6	14,050
	140	55.6	13,400	58.0	13,400	60.0	13,420		140	60.1	12,080	62.2	12,090	64.0	12,100
	150	52.5	11,740	54.8	11,750	56.8	11,770		150	57.5	10,420	59.6	10,430	61.4	10,440
	160	49.3	10,310	51.6	10,320	53.5	10,340		160	54.8	8,970	56.9	8,980	58.6	8,990
	170	45.9	9,060	48.1	9,060	50.0	9,080		170	52.1	7,720	54.1	7,720	55.8	7,740
									180	49.2	6,620	51.2	6,630	52.8	6,640
									190	46.2	5,640	48.1	5,650	49.7	5,670
									200	43.0	4,780	44.9	4,790	46.4	4,810
	40	82.8	29,400*	-	-	-	-		44	82.8	28,990*	-	-	-	-
	50	80.5	28,510*	82.8	25,470*	-	-		50	81.5	28,480*	-	-	-	-
	60	78.0	27,520*	80.4	24,890*	82.7	22,790*		60	79.4	27,700*	81.5	24,760*	-	-
	70	75.6	26,740*	78.0	24,220*	80.2	22,280*		70	77.2	26,960*	79.3	24,260*	81.3	22,190*
	80	73.1	25,920*	75.5	23,700*	77.7	20,960*		80	75.0	26,210*	77.1	23,790*	79.1	21,680*
	90	70.6	25,170*	72.9	23,130*	75.1	19,690*		90	72.8	25,510*	74.9	23,240*	76.9	20,390*
	100	68.1	23,320	70.4	22,540*	72.5	18,490*		100	70.6	22,030	72.7	22,030	74.6	19,300*
	110	65.5	19,940	67.8	19,940	69.9	17,500*		110	68.3	18,640	70.4	18,650	72.3	18,320*
	120	62.8	17,180	65.1	17,190	67.1	16,630*		120	66.0	15,880	68.1	15,890	69.9	15,910
	130	60.1	14,890	62.3	14,900	64.4	14,910		130	63.7	13,580	65.7	13,590	67.5	13,600
	140	57.3	12,940	59.5	12,950	61.5	12,960		140	61.3	11,630	63.3	11,640	65.1	11,660
	150	54.4	11,280	56.6	11,290	58.5	11,310		150	58.8	9,960	60.8	9,970	62.6	9,980
	160	51.4	9,850	53.5	9,860	55.4	9,870		160	56.3	8,520	58.3	8,530	60.0	8,550
	170	48.2	8,590	50.3	8,600	52.1	8,620		170	53.7	7,260	55.7	7,270	57.3	7,280
	180	44.9	7,500	47.0	7,510	48.7	7,520		180	51.0	6,150	52.9	6,160	54.6	6,180
									190	48.2	5,180	50.1	5,180	51.7	5,200
									200	45.2	4,310	47.1	4,320	48.6	4,340
									210	42.1	3,540	44.0	3,550	45.4	3,570
	41	82.9	29,230*	-	-	-	-		45	82.8	28,840*	-	-	-	-
	50	80.8	28,450*	-	-	-	-		50	81.8	28,460*	-	-	-	-
	60	78.5	27,650*	80.8	24,810*	83.0	22,650*		60	79.8	27,720*	81.8	24,760*	-	-
	70	76.2	26,850*	78.5	24,290*	80.6	22,320*		70	77.7	26,950*	79.7	24,230*	81.6	22,130*
	80	73.8	25,990*	76.1	23,760*	78.2	21,170*		80	75.6	26,270*	77.6	23,790*	79.5	21,800*
	90	71.4	25,250*	73.7	23,180*	75.7	19,950*		90	73.5	25,560*	75.5	23,260*	77.4	20,630*
	100	69.0	22,880	71.2	22,690*	73.3	18,810*		100	71.3	21,600	73.3	21,600	75.2	19,490*
	110	66.5	19,500	68.7	19,500	70.7	17,800*		110	69.1	18,210	71.1	18,220	73.0	18,230
	120	64.0	16,740	66.2	16,750	68.2	16,760		120	66.9	15,440	68.9	15,450	70.7	15,460
	130	61.4	14,430	63.6	14,440	65.5	14,460		130	64.7	13,140	66.7	13,140	68.4	13,160
	140	58.7	12,490	60.9	12,500	62.8	12,520		140	62.4	11,190	64.4	11,200	66.1	11,210
	150	56.0	10,830	58.1	10,840	60.0	10,860		150	60.1	9,520	62.0	9,520	63.7	9,540
	160	53.2	9,390	55.3	9,400	57.1	9,410		160	57.7	8,080	59.6	8,080	61.3	8,100
	170	50.2	8,140	52.3	8,150	54.1	8,160		170	55.2	6,810	57.1	6,820	58.7	6,830
	180	47.1	7,040	49.2	7,050	50.9	7,070		180	52.7	5,700	54.5	5,710	56.1	5,730
	190	43.9	6,070	45.9	6,080	47.5	6,100		190	50.0	4,720	51.9	4,730	53.4	4,750
									200	47.3	3,860	49.1	3,860	50.6	3,880
									210	44.4	3,080	46.2	3,090	47.6	3,110
									220	41.3	2,390	43.1	2,400	44.4	2,420

LOAD CHART

HC 165

With 77SI Hammerhead Tip Boom and 102,000 Pound Upper Counterweight #16HL Jib

102,000 lb 360° ANSI B 30.5

70' Jib length						
Boom length	Jib Radius (Feet)	5.0 Deg offset Boom Angle	5.0 Deg offset Rating (Pounds)	15.0 Deg offset Boom Angle	15.0 Deg offset Rating (Pounds)	25.0 Deg offset Boom Angle (Pounds)
	42	82.9	22,110*	-	-	-
	50	81.0	21,490*	-	-	-
	60	78.7	20,710*	81.4	18,400*	-
	70	76.4	19,960*	79.0	17,880*	81.6 16,230*
	80	74.0	19,300*	76.7	17,360*	79.2 15,910*
	90	71.6	18,660*	74.2	16,880*	76.7 15,460*
180°	100	69.2	18,060*	71.8	16,460*	74.2 15,030*
	110	66.7	17,480*	69.3	15,990*	71.7 14,640*
	120	64.2	16,990*	66.8	15,490*	69.1 14,300*
	130	61.6	15,080	64.1	15,070*	66.5 13,810*
	140	58.9	13,140	61.5	13,150	63.7 13,170*
	150	56.2	11,480	58.7	11,490	60.9 11,510
	160	53.4	10,040	55.9	10,050	58.0 10,070
	170	50.4	8,790	52.9	8,800	55.0 8,820
	180	47.3	7,690	49.8	7,700	51.8 7,720

	43	82.9	22,040*	-	-	-
	50	81.4	21,550*	-	-	-
	60	79.2	20,740*	81.7	18,420*	-
	70	76.9	20,000*	79.5	17,870*	81.9 16,210*
	80	74.6	19,340*	77.2	17,450*	79.6 15,880*
	90	72.3	18,800*	74.9	16,980*	77.2 15,460*
190°	100	70.0	18,210*	72.5	16,490*	74.9 15,030*
	110	67.7	17,620*	70.2	16,110*	72.5 14,660*
	120	65.2	16,950	67.7	15,620*	70.0 14,350*
	130	62.8	14,640	65.2	14,650	67.5 14,010*
	140	60.3	12,700	62.7	12,710	64.9 12,720
	150	57.7	11,030	60.1	11,040	62.2 11,050
	160	55.0	9,590	57.4	9,600	59.5 9,620
	170	52.2	8,340	54.6	8,350	56.7 8,360
	180	49.4	7,240	51.7	7,250	53.7 7,270
	190	46.4	6,260	48.7	6,270	50.6 6,290

	44	83.0	22,000*	-	-	-
	50	81.7	21,520*	-	-	-
	60	79.6	20,770*	82.0	18,450*	-
	70	77.4	20,140*	79.9	17,950*	82.2 16,190*
	80	75.2	19,470*	77.7	17,420*	80.0 15,860*
	90	73.0	18,860*	75.5	17,010*	77.7 15,530*
	100	70.8	18,290*	73.2	16,600*	75.5 15,100*
	110	68.5	17,770*	70.9	16,170*	73.2 14,740*
200°	120	66.2	16,520	68.6	15,740*	70.8 14,380*
	130	63.9	14,230	66.3	14,240	68.4 14,120*
	140	61.5	12,280	63.8	12,290	66.0 12,310
	150	59.0	10,610	61.4	10,620	63.4 10,640
	160	56.5	9,170	58.8	9,180	60.9 9,200
	170	53.9	7,920	56.2	7,930	58.2 7,940
	180	51.2	6,810	53.5	6,820	55.4 6,840
	190	48.4	5,840	50.6	5,850	52.5 5,870
	200	45.4	4,970	47.6	4,980	49.4 5,000

Boom length	Jib Radius (Feet)	5.0 Deg offset Boom Angle	5.0 Deg offset Rating (Pounds)	15.0 Deg offset Boom Angle	15.0 Deg offset Rating (Pounds)	25.0 Deg offset Boom Angle (Pounds)
	46	82.8	21,860*	-	-	-
	50	82.0	21,580*	-	-	-
	60	79.9	20,880*	82.3	18,400*	-
	70	77.9	20,210*	80.2	17,960*	82.5 16,210*
	80	75.8	19,580*	78.1	17,510*	80.4 15,860*
	90	73.6	18,980*	76.0	17,020*	78.2 15,510*
210°	100	71.5	18,440*	73.8	16,620*	76.0 15,150*
	110	69.3	17,880*	71.7	16,200*	73.8 14,810*
	120	67.1	16,080	69.4	15,890*	71.6 14,460*
	130	64.9	13,780	67.2	13,780	69.3 13,800
	140	62.6	11,830	64.9	11,840	66.9 11,860
	150	60.2	10,160	62.5	10,170	64.5 10,180
	160	57.8	8,720	60.1	8,730	62.1 8,740
	170	55.4	7,460	57.6	7,470	59.5 7,490
	180	52.8	6,350	55.0	6,360	56.9 6,380
	190	50.2	5,370	52.4	5,380	54.2 5,400
	200	47.4	4,510	49.6	4,520	51.4 4,540
	210	44.6	3,720	46.7	3,730	48.4 3,760

	47	82.9	21,780*	-	-	-
	50	82.3	21,550*	-	-	-
	60	80.3	20,910*	82.6	18,430*	-
	70	78.3	20,250*	80.6	17,960*	82.8 16,120*
	80	76.3	19,620*	78.6	17,490*	80.7 15,860*
	90	74.2	19,010*	76.5	17,100*	78.6 15,550*
	100	72.2	18,540*	74.4	16,640*	76.5 15,210*
	110	70.1	17,970*	72.3	16,290*	74.4 14,820*
220°	120	68.0	15,640	70.2	15,650	72.2 14,530*
	130	65.8	13,330	68.0	13,340	70.1 13,360
	140	63.6	11,390	65.8	11,400	67.8 11,410
	150	61.4	9,710	63.6	9,720	65.5 9,740
	160	59.1	8,270	61.3	8,280	63.2 8,300
	170	56.7	7,010	58.9	7,020	60.8 7,040
	180	54.3	5,900	56.5	5,910	58.3 5,930
	190	51.8	4,920	53.9	4,930	55.8 4,950
	200	49.2	4,050	51.3	4,060	53.1 4,080
	210	46.5	3,270	48.6	3,280	50.3 3,300
	220	43.7	2,570	45.8	2,590	47.4 2,610



LOAD CHART

HC 165

With 77SI Hammerhead Tip Boom and 102,000 Pound Upper Counterweight #16HL Jib

102,000 lb		360°				ANSI B 30.5									
80' Jib length															
Boom length	Jib Radius (Feet)	5.0 Deg offset Boom Angle	5.0 Deg offset Rating (Pounds)	15.0 Deg offset Boom Angle	15.0 Deg offset Rating (Pounds)	25.0 Deg offset Boom Angle	25.0 Deg offset Rating (Pounds)	Boom length	Jib Radius (Feet)	5.0 Deg offset Boom Angle	5.0 Deg offset Rating (Pounds)	15.0 Deg offset Boom Angle	15.0 Deg offset Rating (Pounds)	25.0 Deg offset Boom Angle	25.0 Deg offset Rating (Pounds)
	46	83.0	17,280*	-	-	-	-								
	50	82.2	16,980*	-	-	-	-								
	60	80.1	16,300*	82.9	14,140*	-	-								
	70	78.0	15,680*	80.8	13,680*	-	-								
	80	75.9	15,040*	78.7	13,290*	81.2	11,670*								
	90	73.8	14,490*	76.5	12,790*	79.1	11,250*								
	100	71.7	13,980*	74.4	12,330*	76.9	10,910*								
	110	69.5	13,550*	72.2	11,890*	74.7	10,610*								
200'	120	67.3	13,050*	70.0	11,440*	72.4	10,320*								
	130	65.0	12,490*	67.7	11,120*	70.1	10,090*								
	140	62.8	12,030*	65.4	10,780*	67.8	9,860*								
	150	60.4	10,800	63.0	10,480*	65.4	9,650*								
	160	58.0	9,360	60.6	9,370	62.9	9,390								
	170	55.6	8,100	58.1	8,110	60.4	8,130								
	180	53.0	6,990	55.5	7,000	57.7	7,030								
	190	50.4	6,010	52.9	6,020	55.0	6,050								
	200	47.6	5,150	50.1	5,160	52.2	5,180								
	48	82.8	17,170*	-	-	-	-								
	50	82.4	17,020*	-	-	-	-								
	60	80.5	16,340*	-	-	-	-								
	70	78.4	15,700*	81.1	13,690*	-	-								
	80	76.4	15,120*	79.1	13,300*	81.5	11,660*								
	90	74.4	14,600*	77.0	12,870*	79.5	11,310*								
	100	72.3	14,100*	74.9	12,370*	77.4	10,970*								
	110	70.2	13,610*	72.8	11,940*	75.2	10,650*								
210'	120	68.1	13,210*	70.7	11,550*	73.1	10,360*								
	130	66.0	12,700*	68.5	11,190*	70.9	10,140*								
	140	63.8	12,020	66.3	10,840*	68.6	9,910*								
	150	61.5	10,350	64.1	10,360	66.3	9,670*								
	160	59.3	8,900	61.8	8,910	64.0	8,930								
	170	56.9	7,640	59.4	7,650	61.6	7,670								
	180	54.5	6,530	57.0	6,550	59.1	6,570								
	190	52.0	5,560	54.4	5,570	56.5	5,590								
	200	49.4	4,680	51.8	4,690	53.9	4,720								
	210	46.7	3,910	49.1	3,920	51.1	3,940								
	49	82.9	17,060*	-	-	-	-								
	50	82.7	17,020*	-	-	-	-								
	60	80.8	16,350*	-	-	-	-								
	70	78.8	15,760*	81.4	13,700*	-	-								
	80	76.9	15,220*	79.4	13,320*	81.8	11,670*								
	90	74.9	14,670*	77.5	12,940*	79.8	11,310*								
	100	72.9	14,210*	75.5	12,460*	77.8	10,970*								
	110	70.9	13,700*	73.4	12,000*	75.8	10,670*								
220'	120	68.9	13,280*	71.4	11,650*	73.7	10,400*								
	130	66.8	12,830*	69.3	11,250*	71.6	10,130*								
	140	64.7	11,570	67.2	10,920*	69.4	9,920*								
	150	62.6	9,910	65.0	9,920	67.2	9,730*								
	160	60.4	8,460	62.8	8,470	65.0	8,480								
	170	58.2	7,190	60.6	7,200	62.7	7,220								
	180	55.9	6,090	58.2	6,100	60.3	6,120								
	190	53.5	5,100	55.9	5,110	57.9	5,130								
	200	51.1	4,230	53.4	4,240	55.4	4,260								
	210	48.5	3,450	50.8	3,460	52.8	3,490								
	220	45.9	2,760	48.2	2,770	50.0	2,790								

LOAD CHART

HC 165

**With 77SI Hammerhead Tip Boom and 116,400 Pound Counterweight
#16HL Jib**

108,400 lb + 8,000 lb carbody counterweight								360°				ANSI B 30.5			
40' Jib length															
Boom length	Jib Radius (Feet)	5.0 Deg offset Boom Angle	32,000* Rating (Pounds)	15.0 Deg offset Boom Angle	32,000* Rating (Pounds)	25.0 Deg offset Boom Angle	32,000* Rating (Pounds)	Boom length	Jib Radius (Feet)	5.0 Deg offset Boom Angle	32,000* Rating (Pounds)	15.0 Deg offset Boom Angle	32,000* Rating (Pounds)	25.0 Deg offset Boom Angle	32,000* Rating (Pounds)
100'	26	82.8	32,000*	-	-	-	-	140'	31	82.8	32,000*	-	-	-	-
	30	81.2	32,000*	-	-	-	-		35	81.5	32,000*	-	-	-	-
	35	79.1	32,000*	81.8	32,000*	-	-		40	79.9	32,000*	82.0	32,000*	-	-
	40	77.0	32,000*	79.7	32,000*	82.3	32,000*		50	76.7	32,000*	78.8	32,000*	80.8	32,000*
	50	72.8	32,000*	75.5	32,000*	78.0	31,980*		60	73.4	32,000*	75.5	32,000*	77.4	31,210*
	60	68.5	32,000*	71.2	32,000*	73.6	28,600*		70	70.1	32,000*	72.2	32,000*	74.1	28,730*
	70	64.1	32,000*	66.7	31,930*	69.1	25,990*		80	66.7	32,000*	68.7	32,000*	70.6	26,600*
	80	59.4	32,000*	62.0	28,940*	64.3	23,950*		90	63.2	30,630	65.2	30,640	67.0	24,840*
	90	54.6	30,530*	57.1	26,570*	59.3	22,240*		100	59.6	26,220	61.6	26,230	63.3	23,430*
	100	49.3	27,580*	51.8	24,610*	53.9	20,800*		110	55.8	22,690	57.8	22,700	59.5	22,110*
110'	27	82.9	32,000*	-	-	-	-	150'	32	82.9	32,000*	-	-	-	-
	30	81.7	32,000*	-	-	-	-		35	82.0	32,000*	-	-	-	-
	35	79.8	32,000*	82.4	32,000*	-	-		40	80.5	32,000*	82.5	32,000*	-	-
	40	77.9	32,000*	80.4	32,000*	82.8	32,000*		50	77.4	32,000*	79.4	32,000*	81.3	32,000*
	50	74.0	32,000*	76.5	32,000*	78.9	32,000*		60	74.3	32,000*	76.3	32,000*	78.1	31,750*
	60	70.0	32,000*	72.5	32,000*	74.8	29,340*		70	71.2	32,000*	73.1	32,000*	74.9	29,330*
	70	65.9	32,000*	68.4	32,000*	70.6	26,800*		80	68.0	32,000*	69.9	32,000*	71.7	27,220*
	80	61.7	32,000*	64.1	30,140*	66.3	24,700*		90	64.7	30,250	66.6	30,260	68.3	25,420*
	90	57.2	31,930	59.6	27,640*	61.7	22,940*		100	61.3	25,840	63.2	25,840	64.9	23,940*
	100	52.6	27,520	54.9	25,570*	56.9	21,540*		110	57.8	22,300	59.7	22,300	61.3	22,310
110	47.5	24,000	49.8	23,870*	51.7	20,370*	120	54.2	19,410	56.0	19,410	57.6	19,430		
120'	28	83.0	32,000*	-	-	-	-	130	50.4	17,000	52.2	17,000	53.7	17,010	
	30	82.3	32,000*	-	-	-	-	140	46.3	14,960	48.1	14,970	49.5	14,980	
	35	80.5	32,000*	82.8	32,000*	-	-	150	41.9	13,220	43.7	13,230	45.0	13,240	
	40	78.7	32,000*	81.0	32,000*	-	-	160'	33	82.9	32,000*	-	-	-	-
	50	75.0	32,000*	77.4	32,000*	79.6	32,000*		35	82.4	32,000*	-	-	-	-
	60	71.3	32,000*	73.6	32,000*	75.8	30,030*		40	80.9	32,000*	82.8	32,000*	-	-
	70	67.5	32,000*	69.8	32,000*	71.9	27,480*		50	78.0	32,000*	79.9	32,000*	81.7	32,000*
	80	63.6	32,000*	65.9	31,300*	67.9	25,380*		60	75.1	32,000*	77.0	32,000*	78.8	32,000*
	90	59.5	31,500	61.8	28,700*	63.8	23,650*		70	72.1	32,000*	74.0	32,000*	75.7	29,880*
	100	55.3	27,090	57.5	26,600*	59.4	22,160*		80	69.1	32,000*	71.0	32,000*	72.7	27,770*
110	50.8	23,570	52.9	23,580	54.8	20,990*	90		66.0	29,820	67.9	29,830	69.5	25,960*	
120	45.9	20,680	48.1	20,690	49.8	19,920*	100		62.9	25,390	64.7	25,400	66.3	24,470*	
130'	30	82.7	32,000*	-	-	-	-		110	59.6	21,860	61.4	21,870	63.0	21,880
	35	81.0	32,000*	-	-	-	-	120	56.2	18,960	58.0	18,970	59.5	18,980	
	40	79.3	32,000*	81.6	32,000*	-	-	130	52.7	16,550	54.4	16,550	55.9	16,560	
	50	75.9	32,000*	78.1	32,000*	80.2	32,000*	140	49.0	14,510	50.7	14,510	52.1	14,520	
	60	72.4	32,000*	74.6	32,000*	76.7	30,690*	150	45.1	12,770	46.7	12,780	48.1	12,790	
	70	68.9	32,000*	71.1	32,000*	73.1	28,120*	160	40.8	11,260	42.4	11,270	43.7	11,280	
	80	65.2	32,000*	67.4	32,000*	69.3	26,010*								
	90	61.5	31,070	63.6	29,710*	65.5	24,290*								
	100	57.6	26,660	59.7	26,660	61.5	22,770*								
	110	53.5	23,120	55.5	23,130	57.3	21,590*								
120	49.1	20,230	51.2	20,240	52.8	20,250									
130	44.5	17,830	46.5	17,830	48.0	17,840									



LOAD CHART

HC 165

**With 77SI Hammerhead Tip Boom and 116,400 Pound Counterweight
#16HL Jib**

108,400 lb + 8,000 lb carbody counterweight							360°		ANSI B 30.5						
50' Jib length															
Boom length	Jib Radius (Feet)	5.0 Deg offset Boom Angle	5.0 Deg offset Rating (Pounds)	15.0 Deg offset Boom Angle	15.0 Deg offset Rating (Pounds)	25.0 Deg offset Boom Angle	25.0 Deg offset Rating (Pounds)	Boom length	Jib Radius (Feet)	5.0 Deg offset Boom Angle	5.0 Deg offset Rating (Pounds)	15.0 Deg offset Boom Angle	15.0 Deg offset Rating (Pounds)	25.0 Deg offset Boom Angle	25.0 Deg offset Rating (Pounds)
	40	82.9	32,000*	-	-	-	-		43	82.8	31,930*	-	-	-	-
	50	80.6	31,470*	82.6	28,410*	-	-		50	81.3	31,440*	-	-	-	-
	60	78.3	30,630*	80.2	27,840*	82.0	25,690*		60	79.2	30,650*	81.0	27,690*	82.6	25,540*
	70	76.0	29,840*	77.9	27,180*	79.6	25,260*		70	77.0	29,940*	78.8	27,190*	80.4	25,170*
	80	73.6	29,060*	75.5	26,630*	77.2	24,750*		80	74.9	29,220*	76.6	26,760*	78.2	24,830*
	90	71.2	28,370*	73.1	26,200*	74.8	23,280*		90	72.7	27,540*	74.4	26,200*	76.0	23,890*
	100	68.8	23,970	70.6	23,970	72.3	22,010*		100	70.4	23,100	72.1	23,100	73.7	22,600*
	110	66.3	20,410	68.1	20,410	69.8	20,420		110	68.2	19,530	69.9	19,540	71.4	19,550
200'	120	63.8	17,500	65.6	17,510	67.2	17,520	220'	120	65.9	16,620	67.6	16,630	69.1	16,640
	130	61.2	15,070	63.0	15,080	64.6	15,090		130	63.5	14,200	65.2	14,200	66.7	14,220
	140	58.5	13,030	60.3	13,040	61.9	13,050		140	61.1	12,140	62.8	12,150	64.3	12,160
	150	55.8	11,270	57.6	11,280	59.1	11,290		150	58.7	10,380	60.3	10,390	61.8	10,400
	160	53.0	9,760	54.7	9,770	56.2	9,780		160	56.1	8,860	57.8	8,870	59.2	8,880
	170	50.0	8,440	51.8	8,440	53.2	8,460		170	53.5	7,540	55.1	7,540	56.5	7,560
	180	47.0	7,280	48.7	7,290	50.0	7,300		180	50.8	6,370	52.4	6,380	53.8	6,400
	190	43.7	6,260	45.4	6,270	46.7	6,280		190	48.0	5,350	49.6	5,350	50.9	5,370
	200	40.2	5,340	41.9	5,350	43.1	5,370		200	45.1	4,430	46.6	4,440	47.8	4,460
									210	42.0	3,610	43.5	3,620	44.6	3,640
									220	38.6	2,880	40.1	2,890	41.2	2,910
	41	83.0	32,000*	-	-	-	-								
	50	81.0	31,480*	82.8	28,380*	-	-								
	60	78.8	30,580*	80.6	27,770*	82.3	25,540*								
	70	76.5	29,810*	78.3	27,180*	80.1	25,220*								
	80	74.3	29,100*	76.1	26,680*	77.8	24,820*								
	90	72.0	27,960	73.8	26,250*	75.4	23,600*								
	100	69.6	23,530	71.4	23,530	73.1	22,340*								
	110	67.3	19,970	69.0	19,980	70.7	19,990								
210'	120	64.9	17,060	66.6	17,060	68.2	17,080								
	130	62.4	14,630	64.1	14,640	65.7	14,650								
	140	59.9	12,590	61.6	12,590	63.1	12,610								
	150	57.3	10,830	59.0	10,830	60.5	10,850								
	160	54.6	9,310	56.3	9,320	57.8	9,330								
	170	51.9	7,990	53.5	7,990	54.9	8,010								
	180	49.0	6,830	50.6	6,830	52.0	6,850								
	190	46.0	5,790	47.6	5,800	48.9	5,810								
	200	42.8	4,880	44.4	4,890	45.6	4,910								
	210	39.4	4,070	41.0	4,070	42.1	4,090								
60' Jib length															
Boom length	Jib Radius (Feet)	5.0 Deg offset Boom Angle	5.0 Deg offset Rating (Pounds)	15.0 Deg offset Boom Angle	15.0 Deg offset Rating (Pounds)	25.0 Deg offset Boom Angle	25.0 Deg offset Rating (Pounds)	Boom length	Jib Radius (Feet)	5.0 Deg offset Boom Angle	5.0 Deg offset Rating (Pounds)	15.0 Deg offset Boom Angle	15.0 Deg offset Rating (Pounds)	25.0 Deg offset Boom Angle	25.0 Deg offset Rating (Pounds)
	36	82.9	29,880*	-	-	-	-		37	83.0	29,680*	-	-	-	-
	40	81.8	29,420*	-	-	-	-		40	82.2	29,340*	-	-	-	-
	50	79.1	28,200*	81.8	25,510*	-	-		50	79.6	28,330*	82.2	25,530*	-	-
	60	76.3	27,270*	79.0	24,810*	81.6	22,830*		60	76.9	27,340*	79.5	24,790*	82.0	22,830*
	70	73.5	26,260*	76.2	24,010*	78.7	21,680*		70	74.3	26,490*	76.8	24,170*	79.3	21,980*
	80	70.6	25,410*	73.3	23,400*	75.8	20,150*		80	71.5	25,550*	74.1	23,460*	76.5	20,440*
150'	90	67.7	24,590*	70.4	22,830*	72.8	18,770*	160'	90	68.8	24,830*	71.3	22,930*	73.7	19,080*
	100	64.7	23,830*	67.4	21,900*	69.8	17,590*		100	65.9	24,100*	68.5	22,370*	70.8	17,960*
	110	61.7	22,830	64.3	20,430*	66.6	16,600*		110	63.1	22,380	65.6	21,000*	67.8	16,910*
	120	58.5	19,930	61.1	19,150*	63.4	15,730*		120	60.1	19,480	62.6	19,490	64.8	16,060*
	130	55.2	17,520	57.8	17,520	60.0	15,020*		130	57.0	17,070	59.5	17,080	61.6	15,300*
	140	51.8	15,470	54.3	15,480	56.5	14,350*		140	53.8	15,020	56.3	15,030	58.4	14,600*
	150	48.2	13,740	50.7	13,740	52.8	13,760		150	50.5	13,280	52.9	13,290	54.9	13,310
									160	47.0	11,780	49.3	11,780	51.3	11,800

LOAD CHART

HC 165

**With 77SI Hammerhead Tip Boom and 116,400 Pound Counterweight
#16HL Jib**

108,400 lb + 8,000 lb carbody counterweight							360°					ANSI B 30.5				
60' Jib length																
Boom length	Jib Radius (Feet)	5.0 Deg offset Boom Angle	5.0 Deg offset Rating (Pounds)	15.0 Deg offset Boom Angle	15.0 Deg offset Rating (Pounds)	25.0 Deg offset Boom Angle	25.0 Deg offset Rating (Pounds)	Boom length	Jib Radius (Feet)	5.0 Deg offset Boom Angle	5.0 Deg offset Rating (Pounds)	15.0 Deg offset Boom Angle	15.0 Deg offset Rating (Pounds)	25.0 Deg offset Boom Angle	25.0 Deg offset Rating (Pounds)	
170'	39	82.8	29,550*	-	-	-	-	200'	42	83.0	29,200*	-	-	-	-	
	40	82.5	29,420*	-	-	-	-		50	81.2	28,520*	-	-	-	-	
	50	80.0	28,470*	82.5	25,510*	-	-		60	79.0	27,660*	81.2	24,800*	-	-	
	60	77.5	27,490*	80.0	24,890*	82.3	22,760*		70	76.7	26,840*	78.9	24,240*	81.0	22,240*	
	70	75.0	26,600*	77.4	24,230*	79.7	22,280*		80	74.4	26,140*	76.6	23,710*	78.7	21,460*	
	80	72.4	25,710*	74.8	23,620*	77.1	20,740*		90	72.2	25,420*	74.3	23,200*	76.3	20,160*	
	90	69.7	24,950*	72.2	23,000*	74.4	19,370*		210'	100	69.8	24,210	72.0	22,720*	74.0	19,010*
	100	67.1	24,260*	69.5	22,450*	71.7	18,210*			110	67.5	20,650	69.6	20,660	71.5	18,020*
	110	64.3	21,950	66.7	21,540*	68.9	17,260*			120	65.1	17,750	67.2	17,750	69.1	17,170*
	120	61.5	19,050	63.9	19,050	66.0	16,350*			130	62.6	15,320	64.7	15,330	66.6	15,340
	130	58.6	16,620	61.0	16,630	63.1	15,610*			140	60.1	13,270	62.2	13,280	64.0	13,290
	140	55.6	14,590	58.0	14,590	60.0	14,610			150	57.5	11,520	59.6	11,530	61.4	11,540
	150	52.5	12,830	54.8	12,840	56.8	12,860			160	54.8	10,000	56.9	10,010	58.6	10,020
	160	49.3	11,320	51.6	11,330	53.5	11,350			170	52.1	8,680	54.1	8,680	55.8	8,700
170	45.9	10,010	48.1	10,010	50.0	10,030	180	49.2	7,520	51.2	7,530	52.8	7,540			
							190	46.2	6,480	48.1	6,490	49.7	6,510			
							200	43.0	5,570	44.9	5,580	46.4	5,600			
180'	40	82.8	29,390*	-	-	-	-	220'	44	82.8	28,980*	-	-	-	-	
	50	80.5	28,490*	82.8	25,460*	-	-		50	81.5	28,460*	-	-	-	-	
	60	78.0	27,500*	80.4	24,870*	82.7	22,780*		60	79.4	27,680*	81.5	24,860*	-	-	
	70	75.6	26,720*	78.0	24,200*	80.2	22,270*		70	77.2	26,940*	79.3	24,250*	81.3	22,180*	
	80	73.1	25,890*	75.5	23,680*	77.7	20,950*		80	75.0	26,190*	77.1	23,760*	79.1	21,670*	
	90	70.6	25,140*	72.9	23,110*	75.1	19,680*		90	72.8	25,480*	74.9	23,320*	76.9	20,370*	
	100	68.1	24,420*	70.4	22,610*	72.5	18,550*		210'	100	70.6	23,770	72.7	22,760*	74.6	19,280*
	110	65.5	21,500	67.8	21,500	69.9	17,550*			110	68.3	20,210	70.4	20,220	72.3	18,300*
	120	62.8	18,590	65.1	18,600	67.1	16,680*			120	66.0	17,300	68.1	17,310	69.9	17,330
	130	60.1	16,170	62.3	16,180	64.4	15,900*			130	63.7	14,880	65.7	14,890	67.5	14,900
	140	57.3	14,130	59.5	14,140	61.5	14,150			140	61.3	12,820	63.3	12,830	65.1	12,850
	150	54.4	12,370	56.6	12,380	58.5	12,400			150	58.8	11,060	60.8	11,070	62.6	11,080
	160	51.4	10,860	53.5	10,870	55.4	10,880			160	56.3	9,540	58.3	9,550	60.0	9,570
	170	48.2	9,540	50.3	9,550	52.1	9,570			170	53.7	8,220	55.7	8,230	57.3	8,240
180	44.9	8,390	47.0	8,400	48.7	8,410	180	51.0	7,050	52.9	7,060	54.6	7,080			
							190	48.2	6,030	50.1	6,030	51.7	6,050			
							200	45.2	5,110	47.1	5,120	48.6	5,140			
							210	42.1	4,290	44.0	4,300	45.4	4,320			
190'	41	82.9	29,340*	-	-	-	-	220'	45	82.8	28,830*	-	-	-	-	
	50	80.8	28,440*	-	-	-	-		50	81.8	28,440*	-	-	-	-	
	60	78.5	27,630*	80.8	24,900*	83.0	22,650*		60	79.8	27,700*	81.8	24,750*	-	-	
	70	76.2	26,830*	78.5	24,270*	80.6	22,300*		70	77.7	26,930*	79.7	24,220*	81.6	22,110*	
	80	73.8	26,070*	76.1	23,740*	78.2	21,250*		80	75.6	26,240*	77.6	23,770*	79.5	21,790*	
	90	71.4	25,330*	73.7	23,150*	75.7	19,930*		90	73.5	25,640*	75.5	23,340*	77.4	20,620*	
	100	69.0	24,620	71.2	22,660*	73.3	18,790*		220'	100	71.3	23,340	73.3	22,800*	75.2	19,460*
	110	66.5	21,060	68.7	21,060	70.7	17,770*			110	69.1	19,780	71.1	19,790	73.0	18,550*
	120	64.0	18,150	66.2	18,160	68.2	16,920*			120	66.9	16,860	68.9	16,870	70.7	16,880
	130	61.4	15,730	63.6	15,740	65.5	15,760			130	64.7	14,440	66.7	14,440	68.4	14,460
	140	58.7	13,680	60.9	13,690	62.8	13,710			140	62.4	12,380	64.4	12,390	66.1	12,400
	150	56.0	11,920	58.1	11,930	60.0	11,950			150	60.1	10,630	62.0	10,630	63.7	10,650
	160	53.2	10,410	55.3	10,420	57.1	10,430			160	57.7	9,110	59.6	9,110	61.3	9,130
	170	50.2	9,100	52.3	9,110	54.1	9,120			170	55.2	7,780	57.1	7,790	58.7	7,800
180	47.1	7,930	49.2	7,940	50.9	7,960	180	52.7	6,600	54.5	6,610	56.1	6,630			
190	43.9	6,910	45.9	6,920	47.5	6,940	190	50.0	5,570	51.9	5,580	53.4	5,600			
							200	47.3	4,660	49.1	4,660	50.6	4,680			
							210	44.4	3,840	46.2	3,850	47.6	3,870			
							220	41.3	3,110	43.1	3,120	44.4	3,140			



LOAD CHART

HC 165

**With 77SI Hammerhead Tip Boom and 116,400 Pound Counterweight
#16HL Jib**

108,400 lb + 8,000 lb carbody counterweight						360°				ANSI B 30.5					
70' Jib length															
Boom length	Jib Radius (Feet)	5.0 Deg offset Boom Angle	22.0 Deg offset Rating (Pounds)	15.0 Deg offset Boom Angle	15.0 Deg offset Rating (Pounds)	25.0 Deg offset Boom Angle	25.0 Deg offset Rating (Pounds)	Boom length	Jib Radius (Feet)	5.0 Deg offset Boom Angle	5.0 Deg offset Rating (Pounds)	15.0 Deg offset Boom Angle	15.0 Deg offset Rating (Pounds)	25.0 Deg offset Boom Angle	25.0 Deg offset Rating (Pounds)
	42	82.9	22,100*	-	-	-	-		46	82.8	21,850*	-	-	-	-
	50	81.0	21,480*	-	-	-	-		50	82.0	21,570*	-	-	-	-
	60	78.7	20,700*	81.4	18,390*	-	-		60	79.9	20,860*	82.3	18,390*	-	-
	70	76.4	19,940*	79.0	17,870*	81.6	16,230*		70	77.9	20,190*	80.2	17,940*	82.5	16,200*
	80	74.0	19,280*	76.7	17,350*	79.2	15,900*		80	75.8	19,560*	78.1	17,500*	80.4	15,850*
	90	71.6	18,640*	74.2	16,860*	76.7	15,440*		90	73.6	18,950*	76.0	17,000*	78.2	15,570*
180'	100	69.2	18,040*	71.8	16,440*	74.2	15,020*		100	71.5	18,420*	73.8	16,600*	76.0	15,140*
	110	66.7	17,450*	69.3	15,970*	71.7	14,620*		110	69.3	17,850*	71.7	16,200*	73.8	14,790*
	120	64.2	16,970*	66.8	15,470*	69.1	14,280*	210'	120	67.1	17,400*	69.4	15,870*	71.6	14,440*
	130	61.6	16,370	64.1	15,050*	66.5	13,780*			130	64.9	15,080	67.2	15,080	69.3
	140	58.9	14,330	61.5	14,340	63.7	13,200*		140	62.6	13,020	64.9	13,030	66.9	13,050
	150	56.2	12,570	58.7	12,580	60.9	12,600		150	60.2	11,270	62.5	11,280	64.5	11,290
	160	53.4	11,060	55.9	11,070	58.0	11,090		160	57.8	9,750	60.1	9,760	62.1	9,770
	170	50.4	9,750	52.9	9,760	55.0	9,780		170	55.4	8,420	57.6	8,430	59.5	8,450
	180	47.3	8,580	49.8	8,590	51.8	8,610		180	52.8	7,250	55.0	7,260	56.9	7,280
									190	50.2	6,220	52.4	6,230	54.2	6,250
									200	47.4	5,310	49.6	5,320	51.4	5,340
									210	44.6	4,480	46.7	4,490	48.4	4,520
	43	82.9	22,030*	-	-	-	-		47	82.9	21,770*	-	-	-	-
	50	81.4	21,540*	-	-	-	-		50	82.3	21,540*	-	-	-	-
	60	79.2	20,720*	81.7	18,410*	-	-		60	80.3	20,900*	82.6	18,420*	-	-
	70	76.9	20,070*	79.5	17,940*	81.9	16,200*		70	78.3	20,230*	80.6	17,950*	82.8	16,110*
	80	74.6	19,410*	77.2	17,440*	79.6	15,860*		80	76.3	19,600*	78.6	17,480*	80.7	15,850*
	90	72.3	18,780*	74.9	16,960*	77.2	15,510*		90	74.2	19,070*	76.5	17,090*	78.6	15,540*
190'	100	70.0	18,190*	72.5	16,540*	74.9	15,080*		100	72.2	18,510*	74.4	16,690*	76.5	15,190*
	110	67.7	17,600*	70.2	16,090*	72.5	14,700*		110	70.1	18,030*	72.3	16,270*	74.4	14,870*
	120	65.2	17,130*	67.7	15,600*	70.0	14,330*	220'	120	68.0	17,070	70.2	15,950*	72.2	14,510*
	130	62.8	15,930	65.2	15,190*	67.5	14,010*			130	65.8	14,630	68.0	14,640	70.1
	140	60.3	13,890	62.7	13,900	64.9	13,380*		140	63.6	12,590	65.8	12,600	67.8	12,610
	150	57.7	12,130	60.1	12,140	62.2	12,150		150	61.4	10,820	63.6	10,830	65.5	10,850
	160	55.0	10,610	57.4	10,620	59.5	10,640		160	59.1	9,300	61.3	9,310	63.2	9,330
	170	52.2	9,300	54.6	9,310	56.7	9,320		170	56.7	7,970	58.9	7,980	60.8	8,000
	180	49.4	8,130	51.7	8,140	53.7	8,160		180	54.3	6,800	56.5	6,810	58.3	6,830
	190	46.4	7,100	48.7	7,110	50.6	7,130		190	51.8	5,770	53.9	5,780	55.8	5,800
									200	49.2	4,850	51.3	4,860	53.1	4,880
									210	46.5	4,030	48.6	4,040	50.3	4,060
									220	43.7	3,290	45.8	3,310	47.4	3,330
	44	83.0	21,990*	-	-	-	-								
	50	81.7	21,500*	-	-	-	-								
	60	79.6	20,850*	82.0	18,440*	-	-								
	70	77.4	20,120*	79.9	17,940*	82.2	16,180*								
	80	75.2	19,450*	77.7	17,480*	80.0	15,850*								
	90	73.0	18,840*	75.5	16,990*	77.7	15,510*								
	100	70.8	18,340*	73.2	16,580*	75.5	15,150*								
	110	68.5	17,740*	70.9	16,150*	73.2	14,720*								
200'	120	66.2	17,270*	68.6	15,780*	70.8	14,430*								
	130	63.9	15,520	66.3	15,320*	68.4	14,100*								
	140	61.5	13,470	63.8	13,480	66.0	13,500								
	150	59.0	11,710	61.4	11,720	63.4	11,740								
	160	56.5	10,190	58.8	10,200	60.9	10,220								
	170	53.9	8,880	56.2	8,890	58.2	8,900								
	180	51.2	7,700	53.5	7,710	55.4	7,730								
	190	48.4	6,680	50.6	6,690	52.5	6,710								
	200	45.4	5,760	47.6	5,770	49.4	5,790								

LOAD CHART

HC 165

With 77SI Hammerhead Tip Boom and 116,400 Pound Counterweight #16HL Jib

108,400 lb + 8,000 lb carbody counterweight 360° ANSI B 30.5

80' Jib length															
Boom length	Jib Radius (Feet)	5.0 Deg offset Boom Angle	5.0 Deg offset Rating (Pounds)	15.0 Deg offset Boom Angle	15.0 Deg offset Rating (Pounds)	25.0 Deg offset Boom Angle	25.0 Deg offset Rating (Pounds)	Boom length	Jib Radius (Feet)	5.0 Deg offset Boom Angle	5.0 Deg offset Rating (Pounds)	15.0 Deg offset Boom Angle	15.0 Deg offset Rating (Pounds)	25.0 Deg offset Boom Angle	25.0 Deg offset Rating (Pounds)
	46	83.0	17,270*	-	-	-	-								
	50	82.2	16,970*	-	-	-	-								
	60	80.1	16,290*	82.9	14,140*	-	-								
	70	78.0	15,670*	80.8	13,670*	-	-								
	80	75.9	15,090*	78.7	13,280*	81.2	11,660*								
	90	73.8	14,540*	76.5	12,780*	79.1	11,300*								
	100	71.7	14,020*	74.4	12,320*	76.9	10,950*								
	110	69.5	13,530*	72.2	11,880*	74.7	10,600*								
200'	120	67.3	13,030*	70.0	11,480*	72.4	10,340*								
	130	65.0	12,530*	67.7	11,100*	70.1	10,080*								
	140	62.8	12,070*	65.4	10,760*	67.8	9,840*								
	150	60.4	11,630*	63.0	10,460*	65.4	9,630*								
	160	58.0	10,390	60.6	10,200*	62.9	9,480*								
	170	55.6	9,060	58.1	9,070	60.4	9,090								
	180	53.0	7,890	55.5	7,900	57.7	7,930								
	190	50.4	6,860	52.9	6,870	55.0	6,900								
	200	47.6	5,950	50.1	5,960	52.2	5,980								
	48	82.8	17,160*	-	-	-	-								
	50	82.4	17,010*	-	-	-	-								
	60	80.5	16,330*	-	-	-	-								
	70	78.4	15,690*	81.1	13,680*	-	-								
	80	76.4	15,110*	79.1	13,290*	81.5	11,650*								
	90	74.4	14,590*	77.0	12,850*	79.5	11,300*								
	100	72.3	14,080*	74.9	12,410*	77.4	10,960*								
	110	70.2	13,650*	72.8	11,930*	75.2	10,630*								
210'	120	68.1	13,190*	70.7	11,540*	73.1	10,380*								
	130	66.0	12,680*	68.5	11,170*	70.9	10,120*								
	140	63.8	12,180*	66.3	10,870*	68.6	9,900*								
	150	61.5	11,460	64.1	10,570*	66.3	9,690*								
	160	59.3	9,940	61.8	9,950	64.0	9,490*								
	170	56.9	8,610	59.4	8,620	61.6	8,640								
	180	54.5	7,440	57.0	7,460	59.1	7,480								
	190	52.0	6,410	54.4	6,420	56.5	6,440								
	200	49.4	5,490	51.8	5,500	53.9	5,530								
	210	46.7	4,670	49.1	4,680	51.1	4,700								
	49	82.9	17,050*	-	-	-	-								
	50	82.7	17,020*	-	-	-	-								
	60	80.8	16,340*	-	-	-	-								
	70	78.8	15,740*	81.4	13,690*	-	-								
	80	76.9	15,200*	79.4	13,310*	81.8	11,660*								
	90	74.9	14,660*	77.5	12,920*	79.8	11,300*								
	100	72.9	14,190*	75.5	12,440*	77.8	10,960*								
	110	70.9	13,750*	73.4	12,040*	75.8	10,660*								
220'	120	68.9	13,320*	71.4	11,630*	73.7	10,390*								
	130	66.8	12,810*	69.3	11,250*	71.6	10,160*								
	140	64.7	12,370*	67.2	10,950*	69.4	9,950*								
	150	62.6	11,020	65.0	10,620*	67.2	9,720*								
	160	60.4	9,500	62.8	9,510	65.0	9,520								
	170	58.2	8,160	60.6	8,170	62.7	8,190								
	180	55.9	7,000	58.2	7,010	60.3	7,030								
	190	53.5	5,960	55.9	5,970	57.9	5,990								
	200	51.1	5,040	53.4	5,050	55.4	5,070								
	210	48.5	4,210	50.8	4,220	52.8	4,250								
	220	45.9	3,480	48.2	3,490	50.0	3,510								

Warning

This rating chart is invalid if the crane has been modified or altered by use of other than GENUINE AMERICAN PARTS as such modifications or alterations may affect its capacity or safe operation. See American Crane Corporation Service Bulliten #259.

Ratings in this chart are in POUNDS and do not exceed the percentage of tipping specified for this crane by ANSI B30.5. All ratings require that the crane be standing level on a firm uniformly supporting surface.

Do not lift loads in excess of those shown on this chart. Lifting loads in excess of those shown or operation not in accordance with good operating practice, including limitations shown on page 3499 of Operator's Manual, can cause tipping, structural damage or catastrophic failure.

Asterisk (*) areas on this chart indicate ratings which are limited by strength of material or factors other than stability (tipping).

„JIB RADIUS IN FEET“ is the horizontal distance at ground level from the crane centerline of rotation to a vertical line through the center of gravity of the suspended load.

When using the main boom fall with jib in place, the main fall ratings must be reduced by the jib effective weight shown on the jib rating chart plus twice the weight of all suspended blocks, slings, rope, etc., at the jib fall. See Appendix A.

Blocks, slings, buckets and other load carrying devices are considered part of the load. The weight of standard hoisting ropes for the rating at a given radius has been calculated as part of the boom point load and need not be considered in determining net allowable loads. See Appendix A.

Ratings shown on this chart make no allowance for such factors as out of plumb loads, wind, poor soil conditions, improper inflation of rubber tires and dynamic effects due to excessive operating speeds. The user (operator) must exercise judgement to make allowance for these conditions. See page 3499 of Operator's Manual for detailed information.

No account is taken of the wind force on the load. This effect, which can be substantial for loads with large surface areas, must be considered by the user. In any wind it is strongly recommended that taglines be used to control the load.

BOOM HOIST LINE is 14 parts of 7/8 inch diameter EIPS wire rope with a minimum breaking strength of 79,600 pound.

PENDANT SUSPENSION LINE is 4 parts of 1.375 inch diameter EEIPS wire rope with a minimum breaking strength of 211,000 pound.

JIB BACKSTAY LINE AND FRONTSTAY LINES are 2 parts of 0.875 inch diameter wire rope with a minimum breaking strength of 69,200 pound.

WHIP LINE – 1.125 inch diameter EIPS wire rope with a minimum breaking strength of 130,000 pound or

ALTERNATE WHIP LINE (ROTATION RESISTANT) – 1.125 inch diameter BRIDON ENDURANCE DYFORM 34LR Grade 2160 wire rope with a minimum breaking strength of 167,200 pound.

ERECTION

Erection „OVER THE END“ is with the boom over the idler end with idler tumblers blocked (See operator's manual for blocking instructions).

Erection „OVER THE SIDE“ is with the boom 90° to the sideframes and with the side frames extended. Blocks, slings and other load carrying devices must be on the ground during erection.

LOAD HOISTING INFORMATION - 1.125 inch diameter EIPS wire rope			
MAXIMUM LIFTING CAPACITY - LBS.	MINIMUM PARTS OF LINE	MAXIMUM HOISTING DISTANCE - FT	
		MAIN (FRONT)	AUX. (REAR)
32,000	1	1,312	1,312

LOAD HOISTING INFORMATION (ROTATION RESISTANT LOAD LINE) 1.125 inch diameter BRIDON ENDURANCE DYFORM 34LR Grade 2160 wire rope			
MAXIMUM LIFTING CAPACITY - LBS.	MINIMUM PARTS OF LINE	MAXIMUM HOISTING DISTANCE - FEET	
		MAIN (FRONT)	AUX. (REAR)
32,000	1	1,312	1,312

77SI HAMMERHEAD BOOM COMPOSITION CHART							
BOOM LENGTH (METERS)	BOOM LENGTH (FEET)	BOOM SECTIONS					
		9.1 M 30' 77SI INNER	3.0 M 10' 77S CENTER	6.1 M 20' 77S CENTER	15.2 M 50' 77S CENTER	5.9 M 19.5' 77HL OUTER	0 M 0' HAMMER HEAD
15.2 M	50	1	0	0	0	1	1
18.3 M	60	1	1	0	0	1	1
21.3 M	70	1	1	0	1	1	1
24.4 M	80	1	1	1	0	1	1
27.4 M	90	1	0	2	0	1	1
30.5 M	100	1	0	0	1	1	1
33.5 M	110	1	1	0	1	1	1
36.6 M	120	1	0	1	1	1	1
39.6 M	130	1	1	1	1	1	1
42.7 M	140	1	0	2	1	1	1
45.7 M	150	1	0	0	2	1	1
48.8 M	160	1	1	0	2	1	1
51.8 M	170	1	0	1	2	1	1
54.9 M	180	1	1	1	2	1	1
57.9 M	190	1	0	2	2	1	1
61.0 M	200	1	0	0	3	1	1
64.0 M	210	1	1	0	3	1	1
67.1 M	220	1	0	1	3	1	1
70.1 M	230	1	1	1	3	1	1
73.2 M	240	1	0	2	3	1	1

77SI HAMMERHEAD BOOM MAXIMUM BOOM & JIB SELF-ERECTION DATA				
	OVER THE END		OVER THE SIDE	
	BOOM LENGTH (FEET)	JIB LENGTH (FEET)	BOOM LENGTH (FEET)	JIB LENGTH (FEET)
#16HL JIB	240	0	220	0
	230	0	210	40
	220	80	200	80

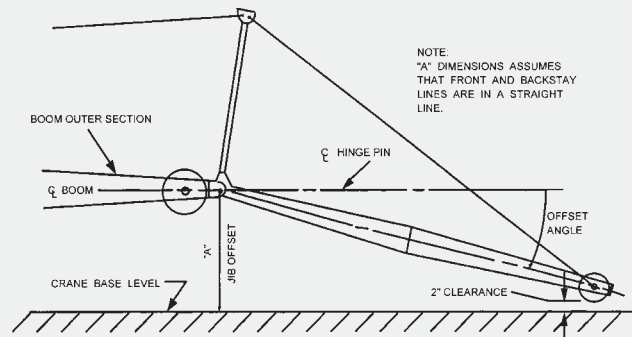

#16HL JIB COMPOSITION CHART								
JIB LENGTH (FEET)	20' INNER	10' CENTER	20' CENTER	20' OUTER	EFF. JIB WEIGHT (POUNDS)	JIB OFFSET \"A\" IN FEET		
						5'	15'	25'
40	1	0	0	1	1,500	4'-10"	10'- 2"	15'- 1"
50	1	1	0	1	2,050	5'- 8"	12'- 1"	18'- 3"
60	1	0	1	1	2,600	6'- 6"	13'-10"	21'- 2"
70	1	1	1	1	3,150	7'- 1"	15'-10"	24'- 4"
80	1	0	2	1	3,700	7'- 9"	17'- 8"	27'- 4"

RANGE DIAGRAM

HC 165

77SI Offset Tip Boom, #16HL Jib

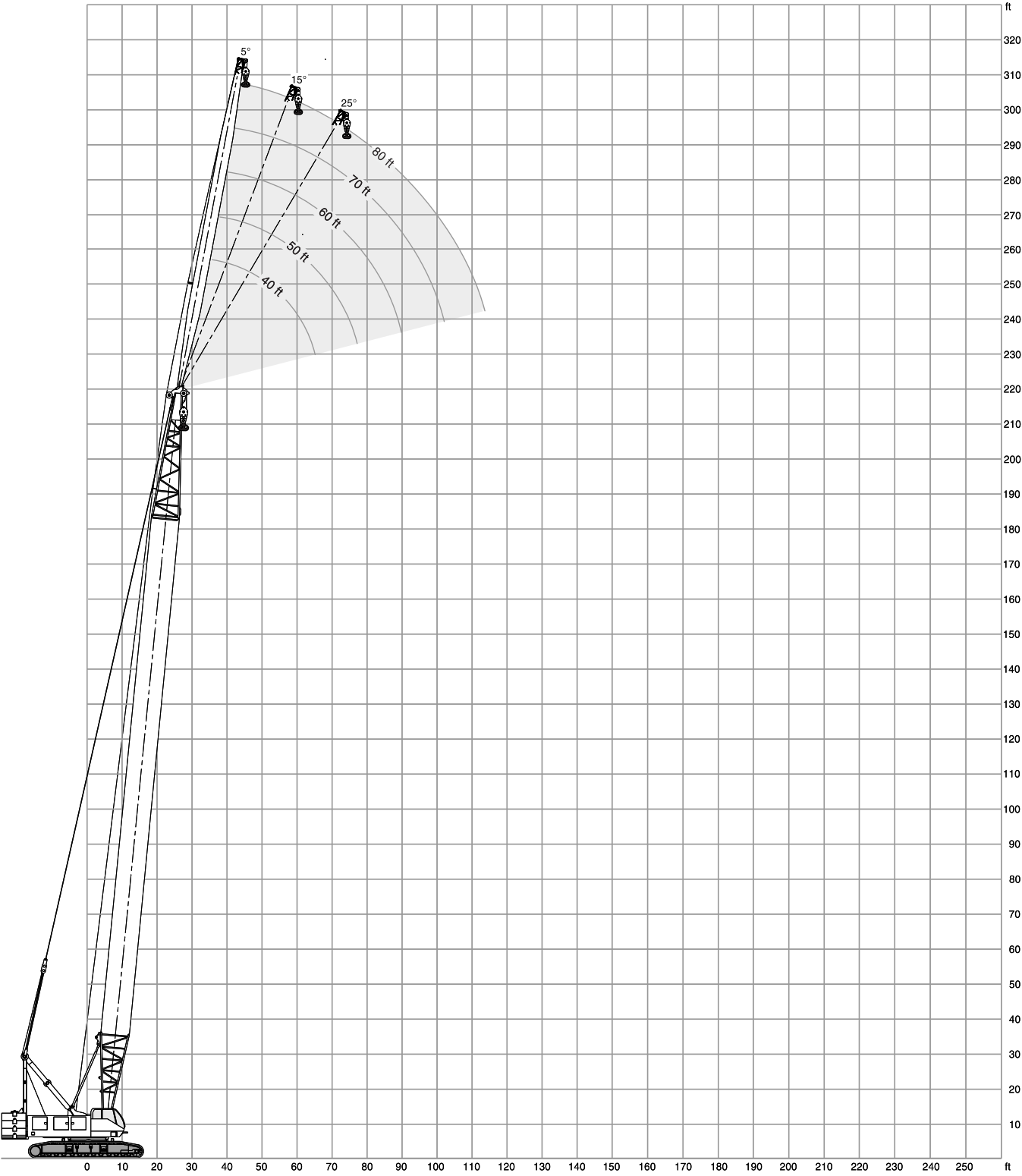

LOAD CHART

HC 165

**With 77SI Offset Tip Boom and 102,000 Pound Upper Counterweight
#16HL Jib**

102,000 lb				360°				ANSI B 30.5							
40' Jib length															
Boom length	Jib Radius (Feet)	5.0 Deg offset Boom Angle	5.0 Deg offset Rating (Pounds)	15.0 Deg offset Boom Angle	15.0 Deg offset Rating (Pounds)	25.0 Deg offset Boom Angle	25.0 Deg offset Rating (Pounds)	Boom length	Jib Radius (Feet)	5.0 Deg offset Boom Angle	5.0 Deg offset Rating (Pounds)	15.0 Deg offset Boom Angle	15.0 Deg offset Rating (Pounds)	25.0 Deg offset Boom Angle	25.0 Deg offset Rating (Pounds)
100'	31	80.6	32,000*	-	-	-	-	140'	37	80.8	32,000*	-	-	-	-
	35	78.9	32,000*	-	-	-	-		40	79.8	32,000*	-	-	-	-
	40	76.9	32,000*	79.6	32,000*	-	-		50	76.6	32,000*	78.7	32,000*	80.7	32,000*
	50	72.6	32,000*	75.3	32,000*	77.8	31,510*		60	73.3	32,000*	75.4	32,000*	77.3	30,910*
	60	68.3	32,000*	71.0	32,000*	73.4	28,280*		70	69.9	32,000*	72.0	32,000*	73.9	28,450*
	70	63.8	32,000*	66.4	31,740*	68.8	25,680*		80	66.5	32,000*	68.6	32,000*	70.4	26,350*
	80	59.2	32,000*	61.7	28,780*	64.0	23,630*		90	63.0	30,350	65.0	30,350	66.8	24,570*
	90	54.2	30,280*	56.8	26,380*	59.0	21,980*		100	59.3	26,180	61.3	26,180	63.1	23,090*
	100	49.0	27,480*	51.4	24,450*	53.5	20,650*		110	55.6	22,830	57.5	22,830	59.2	21,890*
									120	51.6	20,090	53.5	20,100	55.1	20,110
							130	47.4	17,820	49.2	17,830	50.8	17,840		
							140	42.8	15,900	44.7	15,910	46.1	15,920		
110'	32	80.8	32,000*	-	-	-	-	150'	38	81.0	32,000*	-	-	-	-
	35	79.7	32,000*	-	-	-	-		40	80.3	32,000*	-	-	-	-
	40	77.7	32,000*	80.3	32,000*	-	-		50	77.3	32,000*	79.3	32,000*	-	-
	50	73.8	32,000*	76.3	32,000*	78.7	32,000*		60	74.2	32,000*	76.2	32,000*	78.0	31,480*
	60	69.8	32,000*	72.3	32,000*	74.6	28,980*		70	71.0	32,000*	73.0	32,000*	74.8	28,990*
	70	65.7	32,000*	68.1	32,000*	70.4	26,500*		80	67.8	32,000*	69.8	32,000*	71.5	26,990*
	80	61.4	32,000*	63.8	30,030*	66.0	24,370*		90	64.5	29,960	66.4	29,960	68.2	25,210*
	90	57.0	31,470	59.3	27,580*	61.4	22,710*		100	61.1	25,770	63.0	25,780	64.7	23,680*
	100	52.2	27,310	54.6	25,450*	56.6	21,280*		110	57.6	22,430	59.5	22,440	61.1	22,430*
	110	47.2	23,980	49.5	23,790*	51.4	20,120*		120	53.9	19,690	55.8	19,700	57.4	19,710
							130	50.1	17,410	51.9	17,420	53.4	17,430		
							140	46.0	15,490	47.8	15,500	49.2	15,510		
							150	41.6	13,850	43.3	13,850	44.7	13,870		
120'	34	80.7	32,000*	-	-	-	-	160'	40	80.8	32,000*	-	-	-	-
	35	80.3	32,000*	-	-	-	-		50	77.9	32,000*	79.8	32,000*	-	-
	40	78.5	32,000*	80.9	32,000*	-	-		60	75.0	32,000*	76.9	32,000*	78.6	31,940*
	50	74.9	32,000*	77.2	32,000*	79.4	32,000*		70	72.0	32,000*	73.9	32,000*	75.6	29,580*
	60	71.1	32,000*	73.5	32,000*	75.6	29,690*		80	69.0	32,000*	70.8	32,000*	72.5	27,520*
	70	67.3	32,000*	69.6	32,000*	71.7	27,140*		90	65.9	29,540	67.7	29,550	69.4	25,740*
	80	63.4	32,000*	65.6	31,170*	67.7	25,050*		100	62.7	25,360	64.5	25,360	66.1	24,220*
	90	59.3	31,090	61.5	28,640*	63.5	23,330*		110	59.4	22,010	61.2	22,020	62.8	22,030
	100	55.0	26,920	57.2	26,480*	59.1	21,910*		120	56.0	19,280	57.8	19,280	59.3	19,290
	110	50.4	23,590	52.6	23,590	54.5	20,730*		130	52.5	16,990	54.2	17,000	55.7	17,010
120	45.6	20,860	47.7	20,870	49.4	19,770*	140	48.7	15,060	50.4	15,070	51.9	15,080		
							150	44.8	13,420	46.4	13,420	47.8	13,440		
							160	40.5	12,000	42.1	12,010	43.3	12,020		
130'	35	80.9	32,000*	-	-	-	-	170'	41	81.0	32,000*	-	-	-	-
	40	79.2	32,000*	-	-	-	-		50	78.5	32,000*	80.3	32,000*	-	-
	50	75.8	32,000*	78.0	32,000*	80.1	32,000*		60	75.7	32,000*	77.5	32,000*	79.2	32,000*
	60	72.3	32,000*	74.5	32,000*	76.5	30,320*		70	72.9	32,000*	74.7	32,000*	76.3	29,950*
	70	68.7	32,000*	70.9	32,000*	72.9	27,880*		80	70.0	32,000*	71.8	32,000*	73.4	27,990*
	80	65.0	32,000*	67.2	32,000*	69.2	25,790*		90	67.1	29,140	68.8	29,150	70.4	26,220*
	90	61.3	30,750	63.4	29,620*	65.3	23,990*		100	64.1	24,960	65.8	24,960	67.4	24,710*
	100	57.3	26,580	59.4	26,590	61.3	22,550*		110	61.0	21,600	62.7	21,610	64.3	21,620
	110	53.2	23,240	55.3	23,240	57.0	21,300*		120	57.8	18,860	59.5	18,860	61.0	18,880
	120	48.8	20,500	50.9	20,510	52.5	20,280*		130	54.5	16,570	56.2	16,580	57.6	16,590
130	44.1	18,240	46.1	18,250	47.7	18,260	140	51.1	14,650	52.7	14,650	54.1	14,670		
							150	47.5	13,000	49.1	13,010	50.4	13,020		
							160	43.6	11,580	45.2	11,580	46.4	11,600		
							170	39.5	10,340	41.0	10,350	42.1	10,360		

LOAD CHART

HC 165

**With 77SI Offset Tip Boom and 102,000 Pound Upper Counterweight
#16HL Jib**

102,000 lb				360°				ANSI B 30.5							
40' Jib length															
Boom length	Jib Radius (Feet)	5.0 Deg offset Boom Angle	5.0 Deg offset Rating (Pounds)	15.0 Deg offset Boom Angle	15.0 Deg offset Rating (Pounds)	25.0 Deg offset Boom Angle	25.0 Deg offset Rating (Pounds)	Boom length	Jib Radius (Feet)	5.0 Deg offset Boom Angle	5.0 Deg offset Rating (Pounds)	15.0 Deg offset Boom Angle	15.0 Deg offset Rating (Pounds)	25.0 Deg offset Boom Angle	25.0 Deg offset Rating (Pounds)
	43	80.9	32,000*	-	-	-	-								
	50	79.0	32,000*	80.8	32,000*	-	-		48	80.8	32,000*	-	-	-	-
	60	76.4	32,000*	78.1	32,000*	79.7	32,000*		50	80.4	32,000*	-	-	-	-
	70	73.7	32,000*	75.4	32,000*	77.0	30,450*		60	78.0	32,000*	79.6	32,000*	81.0	32,000*
	80	71.0	32,000*	72.7	32,000*	74.2	28,440*		70	75.7	32,000*	77.2	32,000*	78.6	31,760*
	90	68.2	28,770	69.9	28,780	71.4	26,700*		80	73.3	32,000*	74.8	32,000*	76.2	29,790*
180'	100	65.4	24,580	67.0	24,590	68.5	24,600		90	70.9	27,530	72.4	27,540	73.8	27,550
	110	62.4	21,230	64.1	21,230	65.6	21,240		100	68.5	23,330	69.9	23,330	71.3	23,340
	120	59.5	18,480	61.1	18,490	62.5	18,500	210'	110	66.0	19,970	67.4	19,980	68.8	19,990
	130	56.4	16,190	58.0	16,200	59.4	16,210		120	63.4	17,210	64.9	17,220	66.2	17,230
	140	53.2	14,270	54.8	14,270	56.1	14,290		130	60.9	14,930	62.3	14,930	63.6	14,940
	150	49.8	12,620	51.4	12,620	52.7	12,640		140	58.2	12,990	59.6	12,990	60.8	13,000
160	46.3	11,190	47.8	11,200	49.1	11,210	150		55.4	11,330	56.8	11,330	58.0	11,350	
170	42.6	9,950	44.0	9,960	45.2	9,970	160		52.6	9,890	54.0	9,900	55.1	9,910	
	180	38.5	8,870	39.9	8,870	41.0	8,890	170	49.6	8,640	51.0	8,650	52.1	8,660	
								180	46.5	7,550	47.9	7,550	49.0	7,570	
								190	43.3	6,570	44.6	6,580	45.6	6,590	
								200	39.8	5,720	41.1	5,730	42.0	5,740	
								210	36.0	4,960	37.2	4,970	38.1	4,980	
	45	80.8	32,000*	-	-	-	-								
	50	79.5	32,000*	-	-	-	-								
	60	77.0	32,000*	78.6	32,000*	80.2	32,000*		49	81.0	32,000*	-	-	-	-
	70	74.4	32,000*	76.1	32,000*	77.6	30,910*		50	80.7	32,000*	-	-	-	-
	80	71.8	32,000*	73.4	32,000*	74.9	28,870*		60	78.5	32,000*	80.0	32,000*	-	-
	90	69.2	28,350	70.8	28,360	72.3	27,220*		70	76.2	32,000*	77.7	32,000*	79.1	32,000*
190'	100	66.5	24,160	68.1	24,170	69.5	24,180		80	74.0	32,000*	75.4	32,000*	76.8	30,080*
	110	63.7	20,800	65.3	20,810	66.7	20,820		90	71.7	27,110	73.1	27,120	74.4	27,130
	120	60.9	18,060	62.5	18,060	63.9	18,080	220'	100	69.3	22,920	70.8	22,920	72.1	22,930
	130	58.0	15,770	59.6	15,770	60.9	15,780		110	67.0	19,550	68.4	19,550	69.6	19,560
	140	55.0	13,840	56.6	13,850	57.9	13,860		120	64.5	16,800	65.9	16,810	67.2	16,820
	150	51.9	12,190	53.4	12,190	54.7	12,200		130	62.1	14,500	63.5	14,510	64.7	14,520
160	48.7	10,760	50.1	10,760	51.4	10,770	140		59.5	12,560	60.9	12,570	62.1	12,580	
170	45.2	9,510	46.7	9,520	47.8	9,530	150		56.9	10,900	58.3	10,910	59.5	10,920	
	180	41.6	8,420	43.0	8,430	44.1	8,440	160	54.3	9,460	55.6	9,470	56.8	9,480	
	190	37.6	7,460	39.0	7,470	40.0	7,480	170	51.5	8,210	52.8	8,220	53.9	8,230	
								180	48.6	7,110	49.9	7,120	51.0	7,130	
								190	45.6	6,150	46.9	6,150	47.9	6,170	
								200	42.4	5,280	43.6	5,280	44.6	5,300	
								210	39.0	4,510	40.2	4,520	41.1	4,530	
								220	35.3	3,840	36.4	3,840	37.2	3,860	
	46	80.9	32,000*	-	-	-	-								
	50	80.0	32,000*	-	-	-	-								
	60	77.5	32,000*	79.1	32,000*	80.6	32,000*		51	80.9	32,000*	-	-	-	-
	70	75.1	32,000*	76.6	32,000*	78.1	31,340*		60	78.9	32,000*	80.3	32,000*	-	-
	80	72.6	32,000*	74.2	32,000*	75.6	29,380*		70	76.8	32,000*	78.2	32,000*	79.5	32,000*
	90	70.1	27,950	71.6	27,960	73.0	27,670*		80	74.6	32,000*	76.0	32,000*	77.3	30,500*
200'	100	67.5	23,750	69.1	23,760	70.4	23,770		90	72.4	26,730	73.8	26,740	75.0	26,750
	110	64.9	20,390	66.4	20,400	67.8	20,410		100	70.1	22,530	71.5	22,530	72.8	22,540
	120	62.2	17,650	63.8	17,650	65.1	17,660	230'	110	67.9	19,160	69.2	19,160	70.5	19,170
	130	59.5	15,350	61.0	15,360	62.3	15,370		120	65.6	16,410	66.9	16,410	68.1	16,420
	140	56.7	13,410	58.2	13,420	59.4	13,430		130	63.2	14,110	64.5	14,120	65.7	14,130
	150	53.8	11,760	55.2	11,760	56.5	11,770		140	60.8	12,170	62.1	12,170	63.3	12,180
160	50.7	10,320	52.2	10,330	53.4	10,340	150		58.3	10,510	59.6	10,510	60.8	10,520	
170	47.6	9,090	49.0	9,090	50.1	9,100	160		55.8	9,070	57.1	9,070	58.2	9,080	
	180	44.2	7,990	45.6	8,000	46.7	8,010	170	53.2	7,810	54.5	7,820	55.5	7,830	
	190	40.6	7,020	42.0	7,030	43.0	7,050	180	50.5	6,710	51.7	6,720	52.8	6,730	
	200	36.8	6,170	38.1	6,180	39.0	6,200	190	47.6	5,740	48.9	5,750	49.9	5,760	
								200	44.7	4,880	45.9	4,880	46.9	4,900	
								210	41.5	4,100	42.7	4,110	43.6	4,120	
								220	38.2	3,420	39.4	3,420	40.2	3,440	
								230	34.6	2,800	35.7	2,810	36.5	2,830	



LOAD CHART

HC 165

**With 77SI Offset Tip Boom and 102,000 Pound Upper Counterweight
#16HL Jib**

102,000 lb				360°				ANSI B 30.5							
40' Jib length															
Boom length	Jib Radius (Feet)	5.0 Deg offset Boom Angle	Rating (Pounds)	15.0 Deg offset Boom Angle	Rating (Pounds)	25.0 Deg offset Boom Angle	Rating (Pounds)	Boom length	Jib Radius (Feet)	5.0 Deg offset Boom Angle	Rating (Pounds)	15.0 Deg offset Boom Angle	Rating (Pounds)	25.0 Deg offset Boom Angle	Rating (Pounds)
	52	81.0	32,000*	-	-	-	-								
	60	79.3	32,000*	80.7	32,000*	-	-		54	80.9	32,000*	-	-	-	-
	70	77.2	32,000*	78.6	32,000*	79.9	32,000*		60	79.7	32,000*	-	-	-	-
	80	75.1	31,700	76.5	31,700	77.7	30,780*		70	77.7	32,000*	79.0	32,000*	80.2	32,000*
	90	73.0	26,310	74.4	26,320	75.6	26,330		80	75.7	31,290	77.0	31,300	78.2	31,190*
	100	70.9	22,110	72.2	22,110	73.4	22,120		90	73.6	25,890	74.9	25,900	76.1	25,910
	110	68.7	18,740	70.0	18,740	71.2	18,750		100	71.6	21,690	72.8	21,690	74.0	21,700
	120	66.5	15,980	67.8	15,980	69.0	15,990		110	69.5	18,320	70.7	18,320	71.9	18,330
240'	130	64.2	13,680	65.5	13,680	66.7	13,700		120	67.3	15,560	68.6	15,560	69.7	15,570
	140	61.9	11,730	63.2	11,740	64.3	11,750		250'	130	65.2	13,260	66.4	13,260	67.6
	150	59.6	10,070	60.9	10,080	62.0	10,090		140	63.0	11,310	64.2	11,320	65.3	11,330
	160	57.2	8,630	58.4	8,640	59.5	8,650		150	60.7	9,650	62.0	9,650	63.1	9,660
	170	54.7	7,370	55.9	7,380	57.0	7,390		160	58.4	8,200	59.7	8,210	60.7	8,220
	180	52.1	6,270	53.4	6,270	54.4	6,290		170	56.1	6,950	57.3	6,950	58.3	6,960
	190	49.5	5,300	50.7	5,300	51.7	5,320		180	53.7	5,840	54.9	5,850	55.9	5,860
	200	46.7	4,430	47.9	4,440	48.9	4,450		190	51.2	4,860	52.3	4,860	53.3	4,880
	210	43.8	3,660	45.0	3,670	45.9	3,680		200	48.6	3,990	49.7	3,990	50.7	4,010
	220	40.8	2,960	41.9	2,970	42.8	2,980		210	45.9	3,210	47.0	3,220	47.9	3,230
	230	37.5	2,340	38.6	2,350	39.4	2,360		220	43.0	2,520	44.1	2,530	45.0	2,540
									230	40.0	1,890	41.1	1,900	41.9	1,920

50' Jib length															
Boom length	Jib Radius (Feet)	5.0 Deg offset Boom Angle	Rating (Pounds)	15.0 Deg offset Boom Angle	Rating (Pounds)	25.0 Deg offset Boom Angle	Rating (Pounds)	Boom length	Jib Radius (Feet)	5.0 Deg offset Boom Angle	Rating (Pounds)	15.0 Deg offset Boom Angle	Rating (Pounds)	25.0 Deg offset Boom Angle	Rating (Pounds)
	38	80.7	32,000*	-	-	-	-								
	40	80.1	31,900*	-	-	-	-		41	80.8	32,000*	-	-	-	-
	50	76.8	30,710*	79.5	28,230*	-	-		50	78.2	31,020*	80.6	28,330*	-	-
	60	73.6	29,560*	76.2	27,410*	78.6	25,610*		60	75.2	29,930*	77.6	27,520*	79.8	25,640*
130'	70	70.2	28,590*	72.8	26,560*	75.2	23,760*		70	72.3	29,000*	74.6	26,860*	76.8	24,550*
	80	66.8	27,570*	69.4	25,940*	71.7	21,930*		80	69.2	28,120*	71.6	26,210*	73.7	22,850*
	90	63.3	26,760*	65.8	25,250*	68.1	20,400*		90	66.1	27,290*	68.4	25,650*	70.5	21,310*
	100	59.6	26,020*	62.1	23,580*	64.4	19,140*		100	62.9	25,960	65.2	25,070*	67.3	20,000*
	110	55.8	23,430	58.3	21,960*	60.5	18,090*		110	59.7	22,610	61.9	22,620	63.9	18,900*
	120	51.8	20,690	54.3	20,590*	56.4	17,170*		120	56.3	19,880	58.5	19,880	60.4	17,980*
	130	47.6	18,410	50.0	18,420	52.0	16,340*		130	52.7	17,590	54.9	17,600	56.8	17,160*
									140	49.0	15,670	51.1	15,680	53.0	15,690
									150	45.0	14,030	47.1	14,030	48.8	14,050
	39	80.9	32,000*	-	-	-	-								
	40	80.6	32,000*	-	-	-	-								
140'	50	77.5	30,800*	80.1	28,220*	-	-		42	81.0	31,940*	-	-	-	-
	60	74.4	29,810*	76.9	27,440*	79.3	25,670*		50	78.7	31,170*	-	-	-	-
	70	71.3	28,740*	73.8	26,710*	76.1	24,150*		60	76.0	30,160*	78.2	27,640*	80.3	25,700*
	80	68.1	27,890*	70.5	26,030*	72.8	22,350*		70	73.1	29,170*	75.4	26,930*	77.5	24,960*
	90	64.8	27,100*	67.2	25,460*	69.4	20,920*		80	70.3	28,340*	72.5	26,380*	74.5	23,220*
	100	61.4	26,290*	63.8	24,300*	65.9	19,600*		90	67.3	27,610*	69.5	25,740*	71.5	21,690*
	110	57.9	23,020	60.2	22,720*	62.3	18,520*		100	64.3	25,550	66.5	25,190*	68.5	20,400*
	120	54.2	20,280	56.5	20,290	58.6	17,570*		110	61.2	22,200	63.4	22,210	65.3	19,340*
	130	50.3	18,000	52.6	18,010	54.6	16,750*		120	58.1	19,450	60.2	19,460	62.1	18,340*
	140	46.3	16,080	48.5	16,080	50.4	16,100		130	54.8	17,170	56.9	17,180	58.7	17,190
									140	51.3	15,240	53.4	15,250	55.2	15,260
									150	47.7	13,590	49.7	13,600	51.4	13,610
									160	43.8	12,180	45.8	12,190	47.4	12,200

LOAD CHART

HC 165

**With 77SI Offset Tip Boom and 102,000 Pound Upper Counterweight
#16HL Jib**

102,000 lb				360°				ANSI B 30.5							
50' Jib length															
Boom length	Jib Radius (Feet)	5.0 Deg offset Boom Angle	5.0 Deg offset Rating (Pounds)	15.0 Deg offset Boom Angle	15.0 Deg offset Rating (Pounds)	25.0 Deg offset Boom Angle	25.0 Deg offset Rating (Pounds)	Boom length	Jib Radius (Feet)	5.0 Deg offset Boom Angle	5.0 Deg offset Rating (Pounds)	15.0 Deg offset Boom Angle	15.0 Deg offset Rating (Pounds)	25.0 Deg offset Boom Angle	25.0 Deg offset Rating (Pounds)
170'	44	80.8	31,790*	-	-	-	-	200'	49	80.8	31,430*	-	-	-	-
	50	79.3	31,190*	-	-	-	-		50	80.6	31,320*	-	-	-	-
	60	76.6	30,230*	78.8	27,630*	80.8	25,710*		60	78.2	30,580*	80.1	27,800*	-	-
	70	73.9	29,400*	76.1	27,080*	78.1	25,240*		70	75.9	29,760*	77.8	27,210*	79.6	25,200*
	80	71.2	28,560*	73.3	26,430*	75.3	23,620*		80	73.5	29,010*	75.4	26,650*	77.1	24,550*
	90	68.4	27,740*	70.5	25,900*	72.5	22,120*		90	71.1	28,130	73.0	26,090*	74.7	23,100*
	100	65.6	25,130	67.7	25,140	69.6	20,860*		100	68.7	23,930	70.5	23,940	72.2	21,810*
	110	62.7	21,790	64.7	21,790	66.6	19,740*		110	66.2	20,570	68.0	20,580	69.7	20,590
	120	59.7	19,040	61.7	19,050	63.6	18,750*		120	63.6	17,820	65.5	17,830	67.1	17,840
	130	56.6	16,750	58.6	16,760	60.4	16,770		130	61.0	15,530	62.9	15,530	64.5	15,550
140	53.4	14,820	55.4	14,830	57.1	14,840	140	58.4	13,600	60.2	13,600	61.7	13,620		
150	50.1	13,180	52.0	13,180	53.7	13,200	150	55.6	11,940	57.4	11,950	58.9	11,960		
160	46.5	11,750	48.5	11,760	50.0	11,770	160	52.8	10,500	54.5	10,510	56.0	10,530		
170	42.8	10,510	44.7	10,520	46.2	10,530	170	49.8	9,250	51.6	9,260	53.0	9,270		
								180	46.7	8,160	48.4	8,160	49.8	8,180	
								190	43.5	7,190	45.1	7,200	46.4	7,220	
								200	40.0	6,340	41.6	6,350	42.8	6,370	
180'	45	81.0	31,770*	-	-	-	-	210'	50	80.9	31,350*	-	-	-	-
	50	79.7	31,230*	-	-	-	-		60	78.7	30,550*	80.5	27,740*	-	-
	60	77.2	30,360*	79.3	27,700*	-	-		70	76.4	29,800*	78.3	27,230*	80.0	25,170*
	70	74.6	29,520*	76.7	27,140*	78.6	25,220*		80	74.2	29,040*	76.0	26,620*	77.7	24,770*
	80	72.0	28,650*	74.1	26,540*	76.0	23,960*		90	71.9	27,710	73.7	26,200*	75.3	23,470*
	90	69.4	27,990*	71.4	25,950*	73.3	22,470*		100	69.5	23,510	71.3	23,520	72.9	22,180*
	100	66.7	24,760	68.7	24,770	70.5	21,210*		110	67.1	20,150	68.9	20,150	70.5	20,170
	110	64.0	21,400	65.9	21,410	67.7	20,100*		120	64.7	17,400	66.5	17,410	68.1	17,420
	120	61.1	18,660	63.1	18,670	64.9	18,680		130	62.3	15,100	64.0	15,110	65.6	15,120
	130	58.2	16,380	60.2	16,380	61.9	16,400		140	59.7	13,160	61.5	13,170	63.0	13,180
140	55.2	14,440	57.2	14,450	58.8	14,460	150	57.1	11,500	58.9	11,510	60.3	11,520		
150	52.1	12,790	54.0	12,790	55.6	12,810	160	54.5	10,060	56.2	10,070	57.6	10,090		
160	48.9	11,360	50.7	11,360	52.3	11,380	170	51.7	8,820	53.4	8,830	54.8	8,840		
170	45.4	10,120	47.3	10,130	48.8	10,140	180	48.8	7,720	50.4	7,730	51.8	7,740		
180	41.8	9,030	43.6	9,040	45.0	9,060	190	45.8	6,750	47.4	6,750	48.7	6,770		
								200	42.6	5,890	44.2	5,890	45.4	5,910	
								210	39.1	5,120	40.7	5,130	41.8	5,150	
190'	47	80.9	31,550*	-	-	-	-	220'	52	80.8	31,140*	-	-	-	-
	50	80.2	31,380*	-	-	-	-		60	79.1	30,600*	80.9	27,680*	-	-
	60	77.7	30,470*	79.7	27,760*	-	-		70	76.9	29,800*	78.7	27,140*	80.4	25,100*
	70	75.3	29,610*	77.3	27,170*	79.1	25,220*		80	74.8	29,070*	76.5	26,710*	78.1	24,800*
	80	72.8	28,830*	74.8	26,540*	76.6	24,260*		90	72.6	27,290	74.3	26,190*	75.9	23,730*
	90	70.3	28,090*	72.2	26,080*	74.0	22,820*		100	70.3	23,100	72.0	23,110	73.6	22,420*
	100	67.7	24,350	69.7	24,360	71.4	21,520*		110	68.0	19,730	69.8	19,730	71.3	19,750
	110	65.1	20,990	67.0	21,000	68.8	20,420*		120	65.7	16,980	67.4	16,980	69.0	17,000
	120	62.5	18,240	64.3	18,240	66.0	18,260		130	63.4	14,680	65.1	14,690	66.6	14,700
	130	59.7	15,950	61.6	15,960	63.2	15,970		140	61.0	12,740	62.6	12,740	64.1	12,760
140	56.9	14,010	58.8	14,020	60.4	14,030	150	58.5	11,080	60.2	11,080	61.6	11,100		
150	54.0	12,360	55.8	12,360	57.4	12,380	160	56.0	9,640	57.6	9,640	59.0	9,660		
160	50.9	10,920	52.8	10,930	54.3	10,950	170	53.4	8,380	55.0	8,390	56.3	8,400		
170	47.8	9,690	49.5	9,690	51.0	9,710	180	50.6	7,290	52.2	7,300	53.6	7,310		
180	44.4	8,590	46.2	8,600	47.6	8,620	190	47.8	6,310	49.4	6,320	50.7	6,330		
190	40.8	7,620	42.5	7,630	43.9	7,650	200	44.8	5,450	46.4	5,460	47.6	5,470		
								210	41.7	4,680	43.2	4,690	44.4	4,700	
								220	38.4	4,000	39.9	4,010	40.9	4,020	



LOAD CHART

HC 165

**With 77SI Offset Tip Boom and 102,000 Pound Upper Counterweight
#16HL Jib**

102,000 lb				360°				ANSI B 30.5							
50' Jib length															
Boom length	Jib Radius (Feet)	5.0 Deg offset Boom Angle	5.0 Deg offset Rating (Pounds)	15.0 Deg offset Boom Angle	15.0 Deg offset Rating (Pounds)	25.0 Deg offset Boom Angle	25.0 Deg offset Rating (Pounds)	Boom length	Jib Radius (Feet)	5.0 Deg offset Boom Angle	5.0 Deg offset Rating (Pounds)	15.0 Deg offset Boom Angle	15.0 Deg offset Rating (Pounds)	25.0 Deg offset Boom Angle	25.0 Deg offset Rating (Pounds)
	53	81.0	31,080*	-	-	-	-		56	81.0	30,720*	-	-	-	-
	60	79.5	30,600*	-	-	-	-		60	80.2	30,390*	-	-	-	-
	70	77.4	29,850*	79.1	27,190*	80.7	24,980*		70	78.3	29,780*	79.9	27,030*	-	-
	80	75.3	29,110*	77.0	26,710*	78.6	24,700*		80	76.3	29,170*	77.9	26,550*	79.4	24,540*
	90	73.2	26,910	74.9	26,190*	76.4	23,990*		90	74.3	26,080	75.9	26,080	77.4	24,260*
	100	71.0	22,710	72.7	22,720	74.2	22,730		100	72.4	21,870	73.9	21,880	75.3	21,890
	110	68.9	19,340	70.5	19,340	72.0	19,360		110	70.3	18,500	71.9	18,500	73.3	18,520
	120	66.7	16,580	68.3	16,580	69.8	16,600		120	68.3	15,740	69.8	15,740	71.2	15,750
230'	130	64.4	14,280	66.0	14,290	67.5	14,300	250'	130	66.2	13,440	67.8	13,440	69.1	13,450
	140	62.1	12,340	63.7	12,350	65.2	12,360			140	64.1	11,490	65.6	11,490	67.0
	150	59.8	10,680	61.4	10,690	62.8	10,700		150	62.0	9,820	63.5	9,830	64.8	9,840
	160	57.3	9,240	58.9	9,250	60.3	9,260		160	59.8	8,380	61.3	8,390	62.6	8,400
	170	54.9	7,980	56.4	7,990	57.8	8,000		170	57.5	7,120	59.0	7,130	60.3	7,140
	180	52.3	6,880	53.9	6,890	55.2	6,900		180	55.2	6,010	56.7	6,020	57.9	6,030
	190	49.7	5,910	51.2	5,920	52.5	5,930		190	52.8	5,040	54.3	5,040	55.5	5,060
	200	46.9	5,040	48.4	5,050	49.6	5,070		200	50.4	4,160	51.8	4,170	53.0	4,190
	210	44.0	4,270	45.5	4,280	46.6	4,290		210	47.9	3,390	49.3	3,390	50.4	3,410
	220	40.9	3,570	42.4	3,580	43.5	3,600		220	45.2	2,680	46.6	2,690	47.7	2,710
	230	37.6	2,960	39.1	2,970	40.1	2,990		230	42.4	2,060	43.8	2,070	44.8	2,090
	55	80.9	30,840*	-	-	-	-		55	80.9	30,840*	-	-	-	-
	60	79.9	30,530*	-	-	-	-		60	79.9	30,530*	-	-	-	-
	70	77.9	29,880*	79.5	27,100*	-	-		70	77.9	29,880*	79.5	27,100*	-	-
	80	75.8	29,190*	77.5	26,690*	79.0	24,610*		80	75.8	29,190*	77.5	26,690*	79.0	24,610*
	90	73.8	26,490	75.4	26,250*	76.9	24,230*		90	73.8	26,490	75.4	26,250*	76.9	24,230*
	100	71.7	22,290	73.3	22,300	74.8	22,310		100	71.7	22,290	73.3	22,300	74.8	22,310
	110	69.6	18,920	71.2	18,920	72.7	18,940		110	69.6	18,920	71.2	18,920	72.7	18,940
	120	67.5	16,160	69.1	16,160	70.5	16,170		120	67.5	16,160	69.1	16,160	70.5	16,170
240'	130	65.3	13,860	66.9	13,860	68.3	13,880		130	65.3	13,860	66.9	13,860	68.3	13,880
	140	63.1	11,910	64.7	11,920	66.1	11,930		140	63.1	11,910	64.7	11,920	66.1	11,930
	150	60.9	10,250	62.5	10,250	63.8	10,270		150	60.9	10,250	62.5	10,250	63.8	10,270
	160	58.6	8,800	60.1	8,810	61.5	8,830		160	58.6	8,800	60.1	8,810	61.5	8,830
	170	56.3	7,550	57.8	7,550	59.1	7,570		170	56.3	7,550	57.8	7,550	59.1	7,570
	180	53.8	6,440	55.3	6,450	56.6	6,460		180	53.8	6,440	55.3	6,450	56.6	6,460
	190	51.3	5,470	52.8	5,470	54.1	5,490		190	51.3	5,470	52.8	5,470	54.1	5,490
	200	48.7	4,600	50.2	4,600	51.4	4,620		200	48.7	4,600	50.2	4,600	51.4	4,620
	210	46.0	3,820	47.5	3,830	48.6	3,850		210	46.0	3,820	47.5	3,830	48.6	3,850
	220	43.2	3,130	44.6	3,140	45.7	3,160		220	43.2	3,130	44.6	3,140	45.7	3,160
	230	40.2	2,500	41.6	2,510	42.6	2,530		230	40.2	2,500	41.6	2,510	42.6	2,530
	240	37.0	1,940	38.3	1,950	39.3	1,970		240	37.0	1,940	38.3	1,950	39.3	1,970
60' Jib length															
Boom length	Jib Radius (Feet)	5.0 Deg offset Boom Angle	5.0 Deg offset Rating (Pounds)	15.0 Deg offset Boom Angle	15.0 Deg offset Rating (Pounds)	25.0 Deg offset Boom Angle	25.0 Deg offset Rating (Pounds)	Boom length	Jib Radius (Feet)	5.0 Deg offset Boom Angle	5.0 Deg offset Rating (Pounds)	15.0 Deg offset Boom Angle	15.0 Deg offset Rating (Pounds)	25.0 Deg offset Boom Angle	25.0 Deg offset Rating (Pounds)
	43	80.9	28,920*	-	-	-	-		45	80.8	28,710*	-	-	-	-
	50	79.0	28,190*	-	-	-	-		50	79.5	28,220*	-	-	-	-
	60	76.2	27,190*	78.9	24,740*	-	-		60	76.8	27,220*	79.4	24,690*	-	-
	70	73.4	26,160*	76.1	24,040*	78.6	21,560*		70	74.1	26,330*	76.7	24,110*	79.2	21,790*
150'	80	70.5	25,280*	73.2	23,380*	75.7	20,000*		80	71.4	25,470*	74.0	23,480*	76.4	20,320*
	90	67.6	24,480*	70.2	22,750*	72.7	18,670*		90	68.6	24,710*	71.2	22,890*	73.5	18,950*
	100	64.6	23,780*	67.2	21,830*	69.6	17,500*	160'	100	65.8	24,020*	68.3	22,290*	70.6	17,790*
	110	61.5	22,780	64.1	20,370*	66.5	16,520*			110	62.9	22,370	65.4	20,920*	67.7
	120	58.3	20,040	60.9	19,080*	63.2	15,660*		120	59.9	19,620	62.4	19,630	64.6	15,980*
	130	55.0	17,760	57.6	17,770	59.8	14,880*		130	56.8	17,330	59.3	17,340	61.4	15,170*
	140	51.6	15,830	54.1	15,840	56.3	14,230*		140	53.6	15,410	56.0	15,420	58.1	14,540*
	150	47.9	14,180	50.4	14,190	52.5	13,700*		150	50.3	13,760	52.7	13,770	54.7	13,780
									160	46.7	12,330	49.1	12,340	51.0	12,360

LOAD CHART

HC 165

**With 77SI Offset Tip Boom and 102,000 Pound Upper Counterweight
#16HL Jib**

102,000 lb				360°				ANSI B 30.5								
60' Jib length																
Boom length	Jib Radius (Feet)	5.0 Deg offset Boom Angle	28,710* Rating (Pounds)	15.0 Deg offset Boom Angle	24,100* Rating (Pounds)	25.0 Deg offset Boom Angle	18,150* Rating (Pounds)	Boom length	Jib Radius (Feet)	5.0 Deg offset Boom Angle	28,250* Rating (Pounds)	15.0 Deg offset Boom Angle	23,160* Rating (Pounds)	25.0 Deg offset Boom Angle	17,890* Rating (Pounds)	
	46	81.0	28,710*	-	-	-	-		51	80.9	28,250*	-	-	-	-	
	50	79.9	28,370*	-	-	-	-		60	78.9	27,540*	-	-	-	-	
	60	77.4	27,410*	79.9	24,820*	-	-		70	76.6	26,750*	78.8	24,200*	80.9	22,160*	
	70	74.8	26,500*	77.3	24,100*	79.6	22,130*		80	74.4	26,060*	76.5	23,690*	78.6	21,350*	
	80	72.2	25,670*	74.7	23,590*	77.0	20,560*		90	72.0	25,320*	74.2	23,160*	76.2	20,030*	
	90	69.6	24,880*	72.0	22,940*	74.3	19,210*		100	69.7	24,110	71.9	22,720*	73.9	18,950*	
170'	100	66.9	24,210*	69.3	22,410*	71.6	18,150*	200'	110	67.3	20,740	69.5	20,750	71.4	17,890*	
	110	64.2	21,950	66.6	21,450*	68.8	17,160*			120	64.9	17,990	67.0	18,000	69.0	17,080*
	120	61.4	19,210	63.7	19,220	65.9	16,270*			130	62.5	15,690	64.6	15,700	66.4	15,720
	130	58.5	16,920	60.8	16,930	62.9	15,510*		140	59.9	13,760	62.0	13,770	63.9	13,780	
	140	55.5	14,990	57.8	15,000	59.8	14,810*		150	57.3	12,100	59.4	12,110	61.2	12,130	
	150	52.3	13,340	54.6	13,340	56.6	13,360		160	54.6	10,660	56.7	10,670	58.5	10,690	
	160	49.1	11,910	51.3	11,910	53.3	11,930		170	51.9	9,420	53.9	9,430	55.6	9,450	
	170	45.6	10,670	47.9	10,680	49.7	10,700		180	49.0	8,320	51.0	8,330	52.6	8,350	
									190	45.9	7,350	47.9	7,360	49.5	7,370	
									200	42.7	6,500	44.7	6,510	46.2	6,530	
	48	80.8	28,530*	-	-	-	-		53	80.8	28,110*	-	-	-	-	
	50	80.4	28,420*	-	-	-	-		60	79.3	27,580*	-	-	-	-	
	60	77.9	27,470*	80.3	24,840*	-	-		70	77.1	26,900*	79.2	24,200*	-	-	
	70	75.5	26,670*	77.9	24,210*	80.1	22,280*		80	74.9	26,160*	77.0	23,670*	79.0	21,580*	
	80	73.0	25,850*	75.4	23,600*	77.6	20,810*		90	72.7	25,440*	74.8	23,200*	76.8	20,280*	
	90	70.5	25,060*	72.8	23,080*	75.0	19,570*		100	70.5	23,690	72.6	22,740*	74.5	19,130*	
180'	100	67.9	24,410*	70.3	22,540*	72.4	18,400*		110	68.2	20,320	70.3	20,320	72.2	18,220*	
	110	65.3	21,570	67.6	21,580	69.7	17,400*		120	65.9	17,570	68.0	17,580	69.8	17,270*	
	120	62.7	18,830	64.9	18,830	67.0	16,570*	210'	130	63.6	15,270	65.6	15,280	67.4	15,290	
130	59.9	16,540	62.2	16,550	64.2	15,750*			140	61.2	13,330	63.2	13,340	65.0	13,350	
140	57.1	14,600	59.3	14,610	61.3	14,630			150	58.7	11,670	60.7	11,670	62.4	11,690	
	150	54.2	12,950	56.4	12,950	58.3	12,970		160	56.1	10,240	58.1	10,250	59.9	10,260	
	160	51.1	11,520	53.3	11,530	55.2	11,550		170	53.5	8,980	55.5	8,990	57.2	9,010	
	170	48.0	10,280	50.1	10,280	51.9	10,300		180	50.8	7,880	52.8	7,890	54.4	7,910	
	180	44.6	9,180	46.7	9,190	48.4	9,210		190	48.0	6,910	49.9	6,920	51.5	6,940	
									200	45.0	6,050	46.9	6,060	48.4	6,080	
									210	41.9	5,280	43.7	5,290	45.2	5,310	
	49	81.0	28,420*	-	-	-	-		54	80.9	27,970*	-	-	-	-	
	50	80.8	28,350*	-	-	-	-		60	79.7	27,630*	-	-	-	-	
	60	78.4	27,480*	80.7	24,760*	-	-		70	77.6	26,930*	79.6	24,190*	-	-	
	70	76.1	26,720*	78.4	24,200*	80.5	22,240*		80	75.5	26,250*	77.5	23,760*	79.4	21,710*	
	80	73.7	25,940*	76.0	23,700*	78.1	21,050*		90	73.4	25,540*	75.4	23,270*	77.3	20,450*	
	90	71.3	25,200*	73.6	23,090*	75.6	19,790*		100	71.2	23,270	73.2	22,810*	75.1	19,380*	
190'	100	68.9	24,520	71.1	22,630*	73.2	18,670*		110	69.0	19,900	71.0	19,900	72.9	18,380*	
	110	66.4	21,160	68.6	21,170	70.6	17,700*		120	66.8	17,150	68.8	17,150	70.6	17,170	
	120	63.8	18,400	66.0	18,410	68.0	16,790*	220'	130	64.6	14,850	66.5	14,860	68.3	14,870	
130	61.2	16,120	63.4	16,130	65.4	16,000*			140	62.3	12,900	64.2	12,910	66.0	12,930	
140	58.6	14,180	60.7	14,180	62.7	14,200			150	59.9	11,240	61.9	11,250	63.6	11,260	
	150	55.8	12,520	58.0	12,530	59.8	12,540		160	57.5	9,800	59.4	9,810	61.1	9,820	
	160	53.0	11,090	55.1	11,100	56.9	11,120		170	55.0	8,550	56.9	8,560	58.6	8,580	
	170	50.0	9,840	52.1	9,850	53.9	9,870		180	52.5	7,450	54.4	7,460	56.0	7,470	
	180	46.9	8,750	49.0	8,750	50.7	8,770		190	49.8	6,480	51.7	6,490	53.2	6,500	
	190	43.7	7,780	45.7	7,790	47.3	7,810		200	47.1	5,610	48.9	5,620	50.4	5,640	
									210	44.2	4,840	46.0	4,850	47.4	4,870	
									220	41.1	4,140	42.9	4,150	44.2	4,170	



LOAD CHART

HC 165

With 77SI Offset Tip Boom and 102,000 Pound Upper Counterweight
#16HL Jib

102,000 lb		360°				ANSI B 30.5									
70' Jib length															
Boom length	Jib Radius (Feet)	5.0 Deg offset Boom Angle	5.0 Deg offset Rating (Pounds)	15.0 Deg offset Boom Angle	15.0 Deg offset Rating (Pounds)	25.0 Deg offset Boom Angle	25.0 Deg offset Rating (Pounds)	Boom length	Jib Radius (Feet)	5.0 Deg offset Boom Angle	5.0 Deg offset Rating (Pounds)	15.0 Deg offset Boom Angle	15.0 Deg offset Rating (Pounds)	25.0 Deg offset Boom Angle	25.0 Deg offset Rating (Pounds)
190'	52	80.9	21,300*	-	-	-	-	220'	57	80.8	21,020*	-	-	-	-
	60	79.1	20,740*	-	-	-	-		60	80.2	20,800*	-	-	-	-
	70	76.8	19,950*	79.4	17,910*	-	-		70	78.2	20,170*	80.5	17,880*	-	-
	80	74.5	19,320*	77.1	17,350*	79.5	15,870*		80	76.2	19,590*	78.5	17,420*	80.6	15,770*
	90	72.2	18,740*	74.8	16,890*	77.2	15,440*		90	74.1	18,980*	76.4	17,010*	78.6	15,500*
	100	69.9	18,130*	72.4	16,510*	74.8	15,020*		100	72.1	18,500*	74.3	16,610*	76.4	15,210*
	110	67.5	17,580*	70.0	16,110*	72.3	14,680*		110	70.0	17,920*	72.2	16,260*	74.3	14,820*
	120	65.1	17,080*	67.6	15,600*	69.9	14,360*		120	67.8	17,290*	70.1	15,920*	72.1	14,510*
	130	62.6	16,240*	65.1	15,130*	67.3	13,960*		130	65.7	14,990*	67.9	15,000*	69.9	14,200*
	140	60.1	14,310	62.6	14,320	64.8	13,320*		140	63.5	13,040	65.7	13,050	67.7	13,070
200'	150	57.5	12,650	59.9	12,660	62.1	12,680	150	61.2	11,380	63.4	11,390	65.4	11,400	
	160	54.8	11,220	57.2	11,230	59.3	11,250	160	58.9	9,940	61.1	9,950	63.1	9,970	
	170	52.1	9,970	54.4	9,980	56.5	10,000	170	56.6	8,690	58.8	8,690	60.6	8,710	
	180	49.2	8,870	51.5	8,880	53.5	8,900	180	54.2	7,580	56.3	7,590	58.2	7,610	
	190	46.1	7,910	48.4	7,920	50.4	7,940	190	51.7	6,610	53.8	6,620	55.6	6,640	
	53	81.0	21,240*	-	-	-	-	200	49.1	5,740	51.2	5,750	52.9	5,770	
	60	79.5	20,790*	-	-	-	-	210	46.4	4,960	48.4	4,970	50.1	4,990	
	70	77.3	20,110*	79.8	17,920*	-	-	220	43.5	4,270	45.5	4,280	47.2	4,300	
	80	75.1	19,390*	77.6	17,400*	79.9	15,860*	58	80.9	20,970*	-	-	-	-	
	90	72.9	18,830*	75.4	16,940*	77.7	15,520*	60	80.5	20,850*	-	-	-	-	
100	70.7	18,230*	73.1	16,580*	75.4	15,120*	70	78.6	20,270*	80.8	17,900*	-	-		
110	68.4	17,700*	70.8	16,130*	73.1	14,730*	80	76.6	19,650*	78.9	17,460*	81.0	15,780*		
120	66.1	17,210*	68.5	15,720*	70.7	14,420*	90	74.7	19,050*	76.9	17,050*	79.0	15,520*		
130	63.7	15,830	66.1	15,320*	68.3	14,100*	100	72.7	18,540*	74.9	16,660*	76.9	15,230*		
140	61.3	13,900	63.7	13,910	65.8	13,550*	110	70.7	18,070*	72.9	16,280*	74.9	14,910*		
150	58.9	12,240	61.2	12,240	63.3	12,260	120	68.6	16,890*	70.8	15,970*	72.8	14,560*		
160	56.3	10,800	58.7	10,810	60.7	10,820	130	66.5	14,590	68.7	14,590	70.7	14,240*		
170	53.7	9,550	56.0	9,560	58.0	9,580	140	64.4	12,650	66.6	12,660	68.5	12,670		
180	51.0	8,450	53.3	8,460	55.2	8,480	150	62.3	10,980	64.4	10,990	66.3	11,010		
190	48.2	7,480	50.4	7,490	52.3	7,510	160	60.1	9,540	62.2	9,550	64.1	9,570		
200	45.2	6,620	47.4	6,630	49.2	6,650	170	57.9	8,280	59.9	8,290	61.8	8,310		
55	80.9	21,110*	-	-	-	-	180	55.5	7,180	57.6	7,190	59.4	7,210		
60	79.9	20,840*	-	-	-	-	190	53.2	6,210	55.2	6,220	57.0	6,240		
70	77.8	20,100*	80.2	17,940*	-	-	200	50.7	5,330	52.8	5,340	54.5	5,360		
80	75.7	19,530*	78.0	17,440*	80.3	15,840*	210	48.2	4,560	50.2	4,570	51.9	4,590		
90	73.5	18,900*	75.9	17,040*	78.1	15,490*	220	45.5	3,860	47.5	3,870	49.1	3,890		
100	71.4	18,420*	73.7	16,630*	75.9	15,130*	230	42.7	3,230	44.7	3,240	46.2	3,270		
110	69.2	17,850*	71.6	16,200*	73.7	14,760*	60	80.8	20,810*	-	-	-	-		
120	67.0	17,380*	69.3	15,860*	71.5	14,470*	70	79.0	20,240*	-	-	-	-		
130	64.8	15,410	67.1	15,400*	69.2	14,160*	80	77.1	19,710*	79.2	17,460*	-	-		
140	62.5	13,460	64.7	13,470	66.8	13,490	90	75.2	19,110*	77.3	17,080*	79.3	15,430*		
150	60.1	11,800	62.4	11,810	64.4	11,830	100	73.3	18,650*	75.4	16,700*	77.4	15,190*		
160	57.7	10,370	59.9	10,380	61.9	10,400	110	71.3	18,110*	73.4	16,300*	75.4	14,920*		
170	55.2	9,110	57.4	9,120	59.4	9,140	120	69.3	16,460	71.5	16,000*	73.4	14,580*		
180	52.7	8,010	54.9	8,020	56.8	8,040	130	67.3	14,160	69.4	14,170	71.4	14,190		
190	50.0	7,040	52.2	7,050	54.0	7,070	140	65.3	12,220	67.4	12,220	69.3	12,240		
200	47.2	6,170	49.4	6,180	51.2	6,200	150	63.3	10,550	65.3	10,560	67.2	10,580		
210	44.3	5,400	46.5	5,410	48.2	5,430	160	61.2	9,110	63.2	9,110	65.0	9,130		
60	80.8	20,810*	-	-	-	-	170	59.0	7,850	61.1	7,860	62.9	7,880		
70	79.0	20,240*	-	-	-	-	180	56.8	6,740	58.8	6,750	60.6	6,770		
80	77.1	19,710*	79.2	17,460*	-	-	190	54.6	5,770	56.6	5,780	58.3	5,800		
90	75.2	19,110*	77.3	17,080*	79.3	15,430*	200	52.2	4,890	54.2	4,900	55.9	4,920		
100	73.3	18,650*	75.4	16,700*	77.4	15,190*	210	49.8	4,110	51.8	4,120	53.4	4,140		
110	71.3	18,110*	73.4	16,300*	75.4	14,920*	220	47.3	3,420	49.3	3,430	50.9	3,450		
120	69.3	16,460	71.5	16,000*	73.4	14,580*	230	44.7	2,780	46.6	2,790	48.2	2,820		
130	67.3	14,160	69.4	14,170	71.4	14,190	240	42.0	2,210	43.9	2,230	45.3	2,250		
140	65.3	12,220	67.4	12,220	69.3	12,240	60	80.8	20,810*	-	-	-	-		
150	63.3	10,550	65.3	10,560	67.2	10,580	70	79.0	20,240*	-	-	-	-		
160	61.2	9,110	63.2	9,110	65.0	9,130	80	77.1	19,710*	79.2	17,460*	-	-		
170	59.0	7,850	61.1	7,860	62.9	7,880	90	75.2	19,110*	77.3	17,080*	79.3	15,430*		
180	56.8	6,740	58.8	6,750	60.6	6,770	100	73.3	18,650*	75.4	16,700*	77.4	15,190*		
190	54.6	5,770	56.6	5,780	58.3	5,800	110	71.3	18,110*	73.4	16,300*	75.4	14,920*		
200	52.2	4,890	54.2	4,900	55.9	4,920	120	69.3	16,460	71.5	16,000*	73.4	14,580*		
210	49.8	4,110	51.8	4,120	53.4	4,140	130	67.3	14,160	69.4	14,170	71.4	14,190		
220	47.3	3,420	49.3	3,430	50.9	3,450	140	65.3	12,220	67.4	12,220	69.3	12,240		
230	44.7	2,780	46.6	2,790	48.2	2,820	150	63.3	10,550	65.3	10,560	67.2	10,580		
240	42.0	2,210	43.9	2,230	45.3	2,250	160	61.2	9,110	63.2	9,110	65.0	9,130		



LOAD CHART

HC 165

**With 77SI Offset Tip Boom and 102,000 Pound Upper Counterweight
#16HL Jib**

102,000 lb				360°				ANSI B 30.5							
80' Jib length															
Boom length	Jib Radius (Feet)	5.0 Deg offset Boom Angle	16.550* Rating (Pounds)	15.0 Deg offset Boom Angle	12,760* Rating (Pounds)	25.0 Deg offset Boom Angle	11,270* Rating (Pounds)	Boom length	Jib Radius (Feet)	5.0 Deg offset Boom Angle	16,310* Rating (Pounds)	15.0 Deg offset Boom Angle	12,480* Rating (Pounds)	25.0 Deg offset Boom Angle	10,990* Rating (Pounds)
	56	80.9	16,550*	-	-	-	-		61	80.8	16,310*	-	-	-	-
	60	80.0	16,300*	-	-	-	-		70	79.1	15,790*	-	-	-	-
	70	77.9	15,600*	80.7	13,680*	-	-		80	77.2	15,220*	79.7	13,300*	-	-
	80	75.8	15,020*	78.6	13,260*	-	-		90	75.3	14,700*	77.8	12,920*	80.1	11,330*
	90	73.7	14,470*	76.4	12,760*	79.0	11,270*		100	73.4	14,200*	75.9	12,480*	78.1	10,990*
	100	71.6	14,000*	74.3	12,310*	76.8	10,920*		110	71.5	13,770*	73.9	12,080*	76.2	10,670*
200'	110	69.4	13,490*	72.1	11,870*	74.6	10,600*		120	69.5	13,340*	71.9	11,670*	74.2	10,420*
	120	67.2	12,980*	69.8	11,470*	72.3	10,340*		130	67.5	12,960*	69.9	11,320*	72.1	10,180*
	130	64.9	12,480*	67.6	11,080*	70.0	10,060*	230'	140	65.5	12,480*	67.9	10,990*	70.1	9,970*
	140	62.6	12,000*	65.3	10,760*	67.6	9,860*			150	63.4	11,110	65.8	10,720*	67.9
	150	60.3	11,600*	62.9	10,450*	65.2	9,660*		160	61.3	9,680	63.7	9,690	65.8	9,560*
	160	57.9	10,920	60.5	10,190*	62.8	9,450*		170	59.2	8,410	61.5	8,420	63.6	8,440
	170	55.4	9,670	58.0	9,680	60.2	9,290*		180	57.0	7,300	59.3	7,310	61.3	7,340
	180	52.8	8,570	55.4	8,580	57.6	8,600		190	54.7	6,330	57.0	6,340	59.0	6,360
	190	50.2	7,600	52.7	7,610	54.8	7,630		200	52.4	5,460	54.7	5,470	56.6	5,500
	200	47.4	6,730	49.9	6,740	52.0	6,770		210	50.0	4,680	52.2	4,690	54.2	4,720
									220	47.5	3,990	49.7	4,000	51.6	4,020
									230	44.9	3,350	47.1	3,370	48.9	3,390
	57	81.0	16,490*	-	-	-	-		62	80.9	16,250*	-	-	-	-
	60	80.4	16,280*	-	-	-	-		70	79.5	15,800*	-	-	-	-
	70	78.4	15,710*	-	-	-	-		80	77.6	15,260*	80.0	13,270*	-	-
	80	76.3	15,130*	79.0	13,280*	-	-		90	75.8	14,760*	78.2	12,950*	80.4	11,340*
	90	74.3	14,550*	76.9	12,850*	79.4	11,290*		100	73.9	14,270*	76.3	12,590*	78.5	11,010*
	100	72.2	14,090*	74.8	12,350*	77.3	10,940*		110	72.1	13,840*	74.4	12,140*	76.6	10,710*
	110	70.1	13,600*	72.7	11,950*	75.1	10,640*		120	70.2	13,430*	72.5	11,740*	74.7	10,470*
	120	68.0	13,150*	70.6	11,560*	73.0	10,360*		130	68.3	13,050*	70.6	11,420*	72.7	10,190*
210'	130	65.9	12,640*	68.4	11,180*	70.8	10,130*	240'	140	66.3	12,350	68.6	11,080*	70.7	9,990*
	140	63.7	12,160*	66.2	10,840*	68.5	9,900*			150	64.3	10,690	66.6	10,700	68.7
	150	61.4	11,750*	63.9	10,540*	66.2	9,670*		160	62.3	9,240	64.6	9,250	66.7	9,270
	160	59.1	10,490	61.6	10,280*	63.9	9,490*		170	60.2	7,980	62.5	7,990	64.5	8,010
	170	56.8	9,240	59.2	9,250	61.4	9,270		180	58.1	6,880	60.4	6,890	62.4	6,910
	180	54.3	8,140	56.8	8,150	58.9	8,170		190	56.0	5,900	58.2	5,910	60.2	5,930
	190	51.8	7,170	54.3	7,180	56.4	7,200		200	53.8	5,020	56.0	5,040	57.9	5,060
	200	49.2	6,300	51.6	6,310	53.7	6,330		210	51.5	4,240	53.7	4,250	55.6	4,280
	210	46.5	5,520	48.9	5,530	50.9	5,560		220	49.1	3,540	51.3	3,550	53.1	3,580
									230	46.7	2,910	48.8	2,920	50.6	2,940
									240	44.1	2,340	46.2	2,360	47.9	2,380
	59	80.9	16,420*	-	-	-	-								
	60	80.7	16,300*	-	-	-	-								
	70	78.8	15,750*	-	-	-	-								
	80	76.8	15,170*	79.4	13,260*	-	-								
	90	74.8	14,630*	77.4	12,880*	79.8	11,310*								
	100	72.8	14,180*	75.4	12,420*	77.7	10,970*								
	110	70.8	13,690*	73.3	12,010*	75.7	10,670*								
	120	68.8	13,290*	71.3	11,590*	73.6	10,420*								
220'	130	66.7	12,830*	69.2	11,280*	71.5	10,160*								
	140	64.6	12,350*	67.1	10,920*	69.3	9,930*								
	150	62.5	11,510	64.9	10,620*	67.1	9,730*								
	160	60.3	10,070	62.7	10,080	64.9	9,520*								
	170	58.0	8,820	60.4	8,830	62.6	8,850								
	180	55.7	7,710	58.1	7,720	60.2	7,740								
	190	53.3	6,740	55.7	6,750	57.8	6,770								
	200	50.9	5,860	53.2	5,880	55.2	5,900								
	210	48.3	5,090	50.7	5,100	52.6	5,120								
	220	45.7	4,390	48.0	4,400	49.8	4,430								

LOAD CHART

HC 165

**With 77SI Offset Tip Boom and 116,400 Pound Counterweight
#16HL Jib**

108,400 lb + 8,000 lb carbody counterweight							360°					ANSI B 30.5			
40' Jib length															
Boom length	Jib Radius (Feet)	5.0 Deg offset Boom Angle	5.0 Deg offset Rating (Pounds)	15.0 Deg offset Boom Angle	15.0 Deg offset Rating (Pounds)	25.0 Deg offset Boom Angle	25.0 Deg offset Rating (Pounds)	Boom length	Jib Radius (Feet)	5.0 Deg offset Boom Angle	5.0 Deg offset Rating (Pounds)	15.0 Deg offset Boom Angle	15.0 Deg offset Rating (Pounds)	25.0 Deg offset Boom Angle	25.0 Deg offset Rating (Pounds)
100'	31	80.6	32,000*	-	-	-	-	140'	37	80.8	32,000*	-	-	-	-
	35	78.9	32,000*	-	-	-	-		40	79.8	32,000*	-	-	-	-
	40	76.9	32,000*	79.6	32,000*	-	-		50	76.6	32,000*	78.7	32,000*	80.7	32,000*
	50	72.6	32,000*	75.3	32,000*	77.8	31,510*		60	73.3	32,000*	75.4	32,000*	77.3	30,910*
	60	68.3	32,000*	71.0	32,000*	73.4	28,280*		70	69.9	32,000*	72.0	32,000*	73.9	28,450*
	70	63.8	32,000*	66.4	31,740*	68.8	25,680*		80	66.5	32,000*	68.6	32,000*	70.4	26,350*
	80	59.2	32,000*	61.7	28,780*	64.0	23,630*		90	63.0	32,000*	65.0	30,600*	66.8	24,570*
	90	54.2	30,280*	56.8	26,380*	59.0	21,980*		100	59.3	28,010	61.3	28,010	63.1	23,090*
	100	49.0	27,480*	51.4	24,450*	53.5	20,650*		110	55.6	24,480	57.5	24,480	59.2	21,890*
										120	51.6	21,590	53.5	21,600	55.1
110'	32	80.8	32,000*	-	-	-	-	150'	38	81.0	32,000*	-	-	-	-
	35	79.7	32,000*	-	-	-	-		40	80.3	32,000*	-	-	-	-
	40	77.7	32,000*	80.3	32,000*	-	-		50	77.3	32,000*	79.3	32,000*	-	-
	50	73.8	32,000*	76.3	32,000*	78.7	32,000*		60	74.2	32,000*	76.2	32,000*	78.0	31,480*
	60	69.8	32,000*	72.3	32,000*	74.6	28,980*		70	71.0	32,000*	73.0	32,000*	74.8	28,990*
	70	65.7	32,000*	68.1	32,000*	70.4	26,500*		80	67.8	32,000*	69.8	32,000*	71.5	26,990*
	80	61.4	32,000*	63.8	30,030*	66.0	24,370*		90	64.5	32,000*	66.4	31,540*	68.2	25,210*
	90	57.0	32,000*	59.3	27,580*	61.4	22,710*		100	61.1	27,600	63.0	27,610	64.7	23,680*
	100	52.2	29,050*	54.6	25,450*	56.6	21,280*		110	57.6	24,080	59.5	24,090	61.1	22,430*
	110	47.2	25,620	49.5	23,790*	51.4	20,120*		120	53.9	21,190	55.8	21,200	57.4	21,210
120'	34	80.7	32,000*	-	-	-	-	160'	40	80.8	32,000*	-	-	-	-
	35	80.3	32,000*	-	-	-	-		50	77.9	32,000*	79.8	32,000*	-	-
	40	78.5	32,000*	80.9	32,000*	-	-		60	75.0	32,000*	76.9	32,000*	78.6	31,940*
	50	74.9	32,000*	77.2	32,000*	79.4	32,000*		70	72.0	32,000*	73.9	32,000*	75.6	29,580*
	60	71.1	32,000*	73.5	32,000*	75.6	29,690*		80	69.0	32,000*	70.8	32,000*	72.5	27,520*
	70	67.3	32,000*	69.6	32,000*	71.7	27,140*		90	65.9	31,590	67.7	31,600	69.4	25,740*
	80	63.4	32,000*	65.6	31,170*	67.7	25,050*		100	62.7	27,190	64.5	27,190	66.1	24,220*
	90	59.3	32,000*	61.5	28,640*	63.5	23,330*		110	59.4	23,650	61.2	23,660	62.8	22,980*
	100	55.0	28,750	57.2	26,480*	59.1	21,910*		120	56.0	20,770	57.8	20,770	59.3	20,780
	110	50.4	25,240	52.6	24,750*	54.5	20,730*		130	52.5	18,360	54.2	18,370	55.7	18,380
120	45.6	22,360	47.7	22,370	49.4	19,770*	140	48.7	16,330	50.4	16,340	51.9	16,350		
								150	44.8	14,600	46.4	14,600	47.8	14,620	
								160	40.5	13,100	42.1	13,110	43.3	13,120	
130'	35	80.9	32,000*	-	-	-	-	170'	41	81.0	32,000*	-	-	-	-
	40	79.2	32,000*	-	-	-	-		50	78.5	32,000*	80.3	32,000*	-	-
	50	75.8	32,000*	78.0	32,000*	80.1	32,000*		60	75.7	32,000*	77.5	32,000*	79.2	32,000*
	60	72.3	32,000*	74.5	32,000*	76.5	30,320*		70	72.9	32,000*	74.7	32,000*	76.3	29,950*
	70	68.7	32,000*	70.9	32,000*	72.9	27,880*		80	70.0	32,000*	71.8	32,000*	73.4	27,990*
	80	65.0	32,000*	67.2	32,000*	69.2	25,790*		90	67.1	31,190	68.8	31,200	70.4	26,220*
	90	61.3	32,000*	63.4	29,620*	65.3	23,990*		100	64.1	26,790	65.8	26,790	67.4	24,710*
	100	57.3	28,410	59.4	27,530*	61.3	22,550*		110	61.0	23,250	62.7	23,260	64.3	23,270
	110	53.2	24,890	55.3	24,890	57.0	21,300*		120	57.8	20,360	59.5	20,360	61.0	20,380
	120	48.8	22,000	50.9	22,010	52.5	20,280*		130	54.5	17,950	56.2	17,960	57.6	17,970
130	44.1	19,610	46.1	19,620	47.7	19,400*	140	51.1	15,920	52.7	15,920	54.1	15,940		
								150	47.5	14,180	49.1	14,190	50.4	14,200	
								160	43.6	12,680	45.2	12,680	46.4	12,700	
								170	39.5	11,370	41.0	11,380	42.1	11,390	

LOAD CHART

HC 165

**With 77SI Offset Tip Boom and 116,400 Pound Counterweight
#16HL Jib**

108,400 lb + 8,000 lb carbody counterweight							360°					ANSI B 30.5			
40' Jib length															
Boom length	Jib Radius (Feet)	5.0 Deg offset Boom Angle	5.0 Deg offset Rating (Pounds)	15.0 Deg offset Boom Angle	15.0 Deg offset Rating (Pounds)	25.0 Deg offset Boom Angle	25.0 Deg offset Rating (Pounds)	Boom length	Jib Radius (Feet)	5.0 Deg offset Boom Angle	5.0 Deg offset Rating (Pounds)	15.0 Deg offset Boom Angle	15.0 Deg offset Rating (Pounds)	25.0 Deg offset Boom Angle	25.0 Deg offset Rating (Pounds)
180'	43	80.9	32,000*	-	-	-	-	210'	48	80.8	32,000*	-	-	-	-
	50	79.0	32,000*	80.8	32,000*	-	-		50	80.4	32,000*	-	-	-	-
	60	76.4	32,000*	78.1	32,000*	79.7	32,000*		60	78.0	32,000*	79.6	32,000*	81.0	32,000*
	70	73.7	32,000*	75.4	32,000*	77.0	30,450*		70	75.7	32,000*	77.2	32,000*	78.6	31,760*
	80	71.0	32,000*	72.7	32,000*	74.2	28,440*		80	73.3	32,000*	74.8	32,000*	76.2	29,790*
	90	68.2	30,820	69.9	30,830	71.4	26,700*		90	70.9	29,580	72.4	29,590	73.8	28,010*
	100	65.4	26,410	67.0	26,420	68.5	25,170*		100	68.5	25,160	69.9	25,160	71.3	25,170
	110	62.4	22,880	64.1	22,880	65.6	22,890		110	66.0	21,620	67.4	21,630	68.8	21,640
	120	59.5	19,980	61.1	19,990	62.5	20,000		120	63.4	18,710	64.9	18,720	66.2	18,730
	130	56.4	17,570	58.0	17,580	59.4	17,590		130	60.9	16,300	62.3	16,300	63.6	16,310
190'	140	53.2	15,540	54.8	15,540	56.1	15,560	140	58.2	14,260	59.6	14,260	60.8	14,270	
	150	49.8	13,800	51.4	13,800	52.7	13,820	150	55.4	12,510	56.8	12,510	58.0	12,530	
	160	46.3	12,290	47.8	12,300	49.1	12,310	160	52.6	10,990	54.0	11,000	55.1	11,010	
	170	42.6	10,980	44.0	10,990	45.2	11,000	170	49.6	9,670	51.0	9,680	52.1	9,690	
	180	38.5	9,840	39.9	9,840	41.0	9,860	180	46.5	8,520	47.9	8,520	49.0	8,540	
	45	80.8	32,000*	-	-	-	-	190	43.3	7,490	44.6	7,500	45.6	7,510	
	50	79.5	32,000*	-	-	-	-	200	39.8	6,590	41.1	6,600	42.0	6,610	
	60	77.0	32,000*	78.6	32,000*	80.2	32,000*	210	36.0	5,790	37.2	5,800	38.1	5,810	
	70	74.4	32,000*	76.1	32,000*	77.6	30,910*	220'	49	81.0	32,000*	-	-	-	-
	80	71.8	32,000*	73.4	32,000*	74.9	28,870*		50	80.7	32,000*	-	-	-	-
90	69.2	30,410	70.8	30,420	72.3	27,220*	60		78.5	32,000*	80.0	32,000*	-	-	
100	66.5	25,990	68.1	26,000	69.5	25,650*	70		76.2	32,000*	77.7	32,000*	79.1	32,000*	
110	63.7	22,450	65.3	22,460	66.7	22,470	80		74.0	32,000*	75.4	32,000*	76.8	30,080*	
120	60.9	19,560	62.5	19,560	63.9	19,580	90		71.7	29,170	73.1	29,180	74.4	28,440*	
130	58.0	17,150	59.6	17,150	60.9	17,160	100		69.3	24,740	70.8	24,740	72.1	24,750	
140	55.0	15,110	56.6	15,120	57.9	15,130	110		67.0	21,200	68.4	21,200	69.6	21,210	
150	51.9	13,370	53.4	13,370	54.7	13,380	120		64.5	18,290	65.9	18,300	67.2	18,310	
160	48.7	11,860	50.1	11,860	51.4	11,870	130		62.1	15,870	63.5	15,880	64.7	15,890	
200'	170	45.2	10,540	46.7	10,550	47.8	10,560	140	59.5	13,830	60.9	13,840	62.1	13,850	
	180	41.6	9,390	43.0	9,400	44.1	9,410	150	56.9	12,080	58.3	12,090	59.5	12,100	
	190	37.6	8,380	39.0	8,390	40.0	8,400	160	54.3	10,560	55.6	10,570	56.8	10,580	
	46	80.9	32,000*	-	-	-	-	170	51.5	9,240	52.8	9,250	53.9	9,260	
	50	80.0	32,000*	-	-	-	-	180	48.6	8,080	49.9	8,090	51.0	8,100	
	60	77.5	32,000*	79.1	32,000*	80.6	32,000*	190	45.6	7,060	46.9	7,060	47.9	7,080	
	70	75.1	32,000*	76.6	32,000*	78.1	31,340*	200	42.4	6,160	43.6	6,160	44.6	6,180	
	80	72.6	32,000*	74.2	32,000*	75.6	29,380*	210	39.0	5,340	40.2	5,350	41.1	5,360	
	90	70.1	30,000	71.6	30,010	73.0	27,670*	220	35.3	4,620	36.4	4,620	37.2	4,640	
	100	67.5	25,580	69.1	25,590	70.4	25,600	230'	51	80.9	32,000*	-	-	-	-
110	64.9	22,040	66.4	22,050	67.8	22,060	60		78.9	32,000*	80.3	32,000*	-	-	
120	62.2	19,150	63.8	19,150	65.1	19,160	70		76.8	32,000*	78.2	32,000*	79.5	32,000*	
130	59.5	16,720	61.0	16,730	62.3	16,740	80		74.6	32,000*	76.0	32,000*	77.3	30,500*	
140	56.7	14,680	58.2	14,690	59.4	14,700	90		72.4	28,780	73.8	28,790	75.0	28,770*	
150	53.8	12,940	55.2	12,940	56.5	12,950	100		70.1	24,360	71.5	24,360	72.8	24,370	
160	50.7	11,430	52.2	11,440	53.4	11,450	110		67.9	20,810	69.2	20,810	70.5	20,820	
170	47.6	10,120	49.0	10,120	50.1	10,130	120		65.6	17,900	66.9	17,900	68.1	17,910	
180	44.2	8,960	45.6	8,970	46.7	8,980	130		63.2	15,480	64.5	15,490	65.7	15,500	
190	40.6	7,940	42.0	7,950	43.0	7,970	140		60.8	13,440	62.1	13,440	63.3	13,450	
200	36.8	7,040	38.1	7,050	39.0	7,070	150	58.3	11,690	59.6	11,690	60.8	11,700		
								160	55.8	10,170	57.1	10,170	58.2	10,180	
								170	53.2	8,840	54.5	8,850	55.5	8,860	
								180	50.5	7,680	51.7	7,690	52.8	7,700	
								190	47.6	6,650	48.9	6,660	49.9	6,670	
								200	44.7	5,750	45.9	5,750	46.9	5,770	
								210	41.5	4,930	42.7	4,940	43.6	4,950	
								220	38.2	4,210	39.4	4,210	40.2	4,230	
								230	34.6	3,550	35.7	3,560	36.5	3,580	

LOAD CHART

HC 165

**With 77SI Offset Tip Boom and 116,400 Pound Counterweight
#16HL Jib**

108,400 lb + 8,000 lb carbody counterweight							360°					ANSI B 30.5			
40' Jib length															
Boom length	Jib Radius (Feet)	5.0 Deg offset Boom Angle	Rating (Pounds)	15.0 Deg offset Boom Angle	Rating (Pounds)	25.0 Deg offset Boom Angle	Rating (Pounds)	Boom length	Jib Radius (Feet)	5.0 Deg offset Boom Angle	Rating (Pounds)	15.0 Deg offset Boom Angle	Rating (Pounds)	25.0 Deg offset Boom Angle	Rating (Pounds)
	52	81.0	32,000*	-	-	-	-								
	60	79.3	32,000*	80.7	32,000*	-	-		54	80.9	32,000*	-	-	-	-
	70	77.2	32,000*	78.6	32,000*	79.9	32,000*		60	79.7	32,000*	-	-	-	-
	80	75.1	32,000*	76.5	32,000*	77.7	30,780*		70	77.7	32,000*	79.0	32,000*	80.2	32,000*
	90	73.0	28,360	74.4	28,370	75.6	28,380		80	75.7	32,000*	77.0	32,000*	78.2	31,190*
	100	70.9	23,940	72.2	23,940	73.4	23,950		90	73.6	27,950	74.9	27,960	76.1	27,970
	110	68.7	20,390	70.0	20,390	71.2	20,400		100	71.6	23,520	72.8	23,520	74.0	23,530
	120	66.5	17,480	67.8	17,480	69.0	17,490		110	69.5	19,970	70.7	19,970	71.9	19,980
240'	130	64.2	15,050	65.5	15,050	66.7	15,070		120	67.3	17,060	68.6	17,060	69.7	17,070
	140	61.9	13,000	63.2	13,010	64.3	13,020		130	65.2	14,630	66.4	14,630	67.6	14,640
	150	59.6	11,250	60.9	11,260	62.0	11,270		140	63.0	12,580	64.2	12,590	65.3	12,600
	160	57.2	9,730	58.4	9,740	59.5	9,750		150	60.7	10,830	62.0	10,830	63.1	10,840
	170	54.7	8,410	55.9	8,420	57.0	8,430		160	58.4	9,300	59.7	9,310	60.7	9,320
	180	52.1	7,250	53.4	7,250	54.4	7,270		170	56.1	7,980	57.3	7,980	58.3	7,990
	190	49.5	6,220	50.7	6,220	51.7	6,240		180	53.7	6,810	54.9	6,820	55.9	6,830
	200	46.7	5,300	47.9	5,310	48.9	5,320		190	51.2	5,780	52.3	5,780	53.3	5,800
	210	43.8	4,480	45.0	4,490	45.9	4,500		200	48.6	4,870	49.7	4,870	50.7	4,890
	220	40.8	3,750	41.9	3,760	42.8	3,770		210	45.9	4,040	47.0	4,050	47.9	4,060
	230	37.5	3,090	38.6	3,100	39.4	3,110		220	43.0	3,310	44.1	3,320	45.0	3,330
	240	33.9	2,510	35.0	2,520	35.7	2,530		230	40.0	2,640	41.1	2,650	41.9	2,670
									240	36.8	2,050	37.9	2,060	38.6	2,080

50' Jib length															
Boom length	Jib Radius (Feet)	5.0 Deg offset Boom Angle	Rating (Pounds)	15.0 Deg offset Boom Angle	Rating (Pounds)	25.0 Deg offset Boom Angle	Rating (Pounds)	Boom length	Jib Radius (Feet)	5.0 Deg offset Boom Angle	Rating (Pounds)	15.0 Deg offset Boom Angle	Rating (Pounds)	25.0 Deg offset Boom Angle	Rating (Pounds)
	38	80.7	32,000*	-	-	-	-								
	40	80.1	31,900*	-	-	-	-		41	80.8	32,000*	-	-	-	-
	50	76.8	30,710*	79.5	28,230*	-	-		50	78.2	31,020*	80.6	28,330*	-	-
	60	73.6	29,560*	76.2	27,410*	78.6	25,610*		60	75.2	29,930*	77.6	27,520*	79.8	25,640*
130'	70	70.2	28,590*	72.8	26,560*	75.2	23,760*		70	72.3	29,000*	74.6	26,860*	76.8	24,550*
	80	66.8	27,570*	69.4	25,940*	71.7	21,930*		80	69.2	28,120*	71.6	26,210*	73.7	22,850*
	90	63.3	26,760*	65.8	25,250*	68.1	20,400*		90	66.1	27,290*	68.4	25,650*	70.5	21,310*
	100	59.6	26,020*	62.1	23,580*	64.4	19,140*		100	62.9	26,560*	65.2	25,070*	67.3	20,000*
	110	55.8	25,070	58.3	21,960*	60.5	18,090*		110	59.7	24,260	61.9	23,410*	63.9	18,900*
	120	51.8	22,190	54.3	20,590*	56.4	17,170*		120	56.3	21,380	58.5	21,380	60.4	17,980*
	130	47.6	19,790	50.0	19,480*	52.0	16,340*		130	52.7	18,970	54.9	18,980	56.8	17,160*
									140	49.0	16,940	51.1	16,950	53.0	16,430*
									150	45.0	15,210	47.1	15,210	48.8	15,230
	39	80.9	32,000*	-	-	-	-								
	40	80.6	32,000*	-	-	-	-		42	81.0	31,940*	-	-	-	-
	50	77.5	30,800*	80.1	28,220*	-	-		50	78.7	31,170*	-	-	-	-
	60	74.4	29,810*	76.9	27,440*	79.3	25,670*		60	76.0	30,160*	78.2	27,640*	80.3	25,700*
140'	70	71.3	28,740*	73.8	26,710*	76.1	24,150*		70	73.1	29,170*	75.4	26,930*	77.5	24,960*
	80	68.1	27,890*	70.5	26,030*	72.8	22,350*		80	70.3	28,340*	72.5	26,380*	74.5	23,220*
	90	64.8	27,100*	67.2	25,460*	69.4	20,920*		90	67.3	27,610*	69.5	25,740*	71.5	21,690*
	100	61.4	26,290*	63.8	24,300*	65.9	19,600*		100	64.3	26,890*	66.5	25,190*	68.5	20,400*
	110	57.9	24,660	60.2	22,720*	62.3	18,520*		110	61.2	23,840	63.4	23,850	65.3	19,340*
	120	54.2	21,770	56.5	21,310*	58.6	17,570*		120	58.1	20,950	60.2	20,960	62.1	18,340*
	130	50.3	19,370	52.6	19,380	54.6	16,750*		130	54.8	18,540	56.9	18,550	58.7	17,500*
	140	46.3	17,350	48.5	17,350	50.4	16,100*		140	51.3	16,510	53.4	16,520	55.2	16,530
									150	47.7	14,770	49.7	14,780	51.4	14,790
									160	43.8	13,280	45.8	13,290	47.4	13,300



LOAD CHART

HC 165

**With 77SI Offset Tip Boom and 116,400 Pound Counterweight
#16HL Jib**

108,400 lb + 8,000 lb carbody counterweight								360°				ANSI B 30.5				
50' Jib length																
Boom length	Jib Radius (Feet)	5.0 Deg offset Boom Angle	5.0 Deg offset Rating (Pounds)	15.0 Deg offset Boom Angle	15.0 Deg offset Rating (Pounds)	25.0 Deg offset Boom Angle	25.0 Deg offset Rating (Pounds)	Boom length	Jib Radius (Feet)	5.0 Deg offset Boom Angle	5.0 Deg offset Rating (Pounds)	15.0 Deg offset Boom Angle	15.0 Deg offset Rating (Pounds)	25.0 Deg offset Boom Angle	25.0 Deg offset Rating (Pounds)	
170'	44	80.8	31,790*	-	-	-	-	200'	49	80.8	31,430*	-	-	-	-	
	50	79.3	31,190*	-	-	-	-		50	80.6	31,320*	-	-	-	-	
	60	76.6	30,230*	78.8	27,630*	80.8	25,710*		60	78.2	30,580*	80.1	27,800*	-	-	
	70	73.9	29,400*	76.1	27,080*	78.1	25,240*		70	75.9	29,760*	77.8	27,210*	79.6	25,200*	
	80	71.2	28,560*	73.3	26,430*	75.3	23,620*		80	73.5	29,010*	75.4	26,650*	77.1	24,550*	
	90	68.4	27,740*	70.5	25,900*	72.5	22,120*		90	71.1	28,290*	73.0	26,090*	74.7	23,100*	
	100	65.6	26,960	67.7	25,390*	69.6	20,860*		100	68.7	25,760	70.5	25,700*	72.2	21,810*	
	110	62.7	23,430	64.7	23,430	66.6	19,740*		110	66.2	22,220	68.0	22,230	69.7	20,740*	
	120	59.7	20,530	61.7	20,540	63.6	18,750*		120	63.6	19,320	65.5	19,230	67.1	19,340	
	130	56.6	18,120	58.6	18,130	60.4	17,850*		130	61.0	16,910	62.9	16,910	64.5	16,930	
140	53.4	16,090	55.4	16,100	57.1	16,110	140	58.4	14,870	60.2	14,870	61.7	14,890			
150	50.1	14,350	52.0	14,350	53.7	14,370	150	55.6	13,120	57.4	13,130	58.9	13,140			
160	46.5	12,850	48.5	12,860	50.0	12,870	160	52.8	11,600	54.5	11,610	56.0	11,630			
170	42.8	11,540	44.7	11,550	46.2	11,560	170	49.8	10,290	51.6	10,300	53.0	10,310			
180'	45	81.0	31,770*	-	-	-	-	210'	180	46.7	9,140	48.4	9,140	49.8	9,160	
	50	79.7	31,230*	-	-	-	-		190	43.5	8,110	45.1	8,120	46.4	8,140	
	60	77.2	30,360*	79.3	27,700*	-	-		200	40.0	7,210	41.6	7,220	42.8	7,240	
	70	74.6	29,520*	76.7	27,140*	78.6	25,220*		220'	50	80.9	31,350*	-	-	-	-
	80	72.0	28,650*	74.1	26,540*	76.0	23,960*			60	78.7	30,550*	80.5	27,740*	-	-
	90	69.4	27,990*	71.4	25,950*	73.3	22,470*			70	76.4	29,800*	78.3	27,230*	80.0	25,170*
	100	66.7	26,590	68.7	25,480*	70.5	21,210*			80	74.2	29,040*	76.0	26,620*	77.7	24,770*
	110	64.0	23,050	65.9	23,060	67.7	20,100*			90	71.9	28,360*	73.7	26,200*	75.3	23,470*
	120	61.1	20,160	63.1	20,170	64.9	19,070*			100	69.5	25,340	71.3	25,350	72.9	22,180*
	130	58.2	17,750	60.2	17,750	61.9	17,770			110	67.1	21,800	68.9	21,800	70.5	21,080*
140	55.2	15,710	57.2	15,720	58.8	15,730	120	64.7		18,890	66.5	18,900	68.1	18,910		
150	52.1	13,970	54.0	13,970	55.6	13,990	130	62.3		16,470	64.0	16,480	65.6	16,490		
160	48.9	12,470	50.7	12,470	52.3	12,490	140	59.7		14,430	61.5	14,440	63.0	14,450		
170	45.4	11,150	47.3	11,160	48.8	11,170	150	57.1	12,680	58.9	12,690	60.3	12,700			
180	41.8	10,000	43.6	10,010	45.0	10,030	160	54.5	11,160	56.2	11,170	57.6	11,190			
190'	47	80.9	31,550*	-	-	-	-	170	51.7	9,850	53.4	9,860	54.8	9,870		
	50	80.2	31,380*	-	-	-	-	180	48.8	8,690	50.4	8,700	51.8	8,710		
	60	77.7	30,470*	79.7	27,760*	-	-	190	45.8	7,670	47.4	7,670	48.7	7,690		
	70	75.3	29,610*	77.3	27,170*	79.1	25,220*	200	42.6	6,760	44.2	6,760	45.4	6,780		
	80	72.8	28,830*	74.8	26,540*	76.6	24,260*	210	39.1	5,950	40.7	5,960	41.8	5,980		
	90	70.3	28,090*	72.2	26,080*	74.0	22,820*	220'	52	80.8	31,140*	-	-	-	-	
	100	67.7	26,170	69.7	25,530*	71.4	21,520*		60	79.1	30,600*	80.9	27,680*	-	-	
	110	65.1	22,630	67.0	22,640	68.8	20,420*		70	76.9	29,800*	78.7	27,140*	80.4	25,100*	
	120	62.5	19,740	64.3	19,740	66.0	19,400*		80	74.8	29,070*	76.5	26,710*	78.1	24,800*	
	130	59.7	17,320	61.6	17,330	63.2	17,340		90	72.6	28,420*	74.3	26,190*	75.9	23,730*	
140	56.9	15,280	58.8	15,290	60.4	15,300	100		70.3	24,920	72.0	24,930	73.6	22,420*		
150	54.0	13,540	55.8	13,540	57.4	13,560	110		68.0	21,380	69.8	21,380	71.3	21,380*		
160	50.9	12,030	52.8	12,040	54.3	12,060	120		65.7	18,470	67.4	18,470	69.0	18,490		
170	47.8	10,720	49.5	10,720	51.0	10,740	130		63.4	16,050	65.1	16,060	66.6	16,070		
180	44.4	9,560	46.2	9,570	47.6	9,590	140		61.0	14,010	62.6	14,010	64.1	14,030		
190	40.8	8,540	42.5	8,550	43.9	8,570	150	58.5	12,260	60.2	12,260	61.6	12,280			
200'	160	56.0	10,740	57.6	10,740	59.0	10,760	160	56.0	10,740	57.6	10,740	59.0	10,760		
	170	53.4	9,420	55.0	9,430	56.3	9,440	170	53.4	9,420	55.0	9,430	56.3	9,440		
	180	50.6	8,260	52.2	8,270	53.6	8,280	180	50.6	8,260	52.2	8,270	53.6	8,280		
	190	47.8	7,230	49.4	7,240	50.7	7,250	190	47.8	7,230	49.4	7,240	50.7	7,250		
	200	44.8	6,320	46.4	6,330	47.6	6,340	200	44.8	6,320	46.4	6,330	47.6	6,340		
	210	41.7	5,510	43.2	5,520	44.4	5,530	210	41.7	5,510	43.2	5,520	44.4	5,530		
220	38.4	4,780	39.9	4,790	40.9	4,800	220	38.4	4,780	39.9	4,790	40.9	4,800			

LOAD CHART

HC 165

**With 77SI Offset Tip Boom and 116,400 Pound Counterweight
#16HL Jib**

108,400 lb + 8,000 lb carbody counterweight 360° ANSI B 30.5

50' Jib length							360°								
Boom length	Jib Radius (Feet)	5.0 Deg offset Boom Angle	Rating (Pounds)	15.0 Deg offset Boom Angle	Rating (Pounds)	25.0 Deg offset Boom Angle	Rating (Pounds)	Boom length	Jib Radius (Feet)	5.0 Deg offset Boom Angle	Rating (Pounds)	15.0 Deg offset Boom Angle	Rating (Pounds)	25.0 Deg offset Boom Angle	Rating (Pounds)
	53	81.0	31,080*	-	-	-	-								
	60	79.5	30,600*	-	-	-	-		56	81.0	30,720*	-	-	-	-
	70	77.4	29,850*	79.1	27,190*	80.7	24,980*		60	80.2	30,390*	-	-	-	-
	80	75.3	29,110*	77.0	26,710*	78.6	24,700*		70	78.3	29,780*	79.9	27,030*	-	-
	90	73.2	28,480*	74.9	26,190*	76.4	23,990*		80	76.3	29,170*	77.9	26,550*	79.4	24,540*
	100	71.0	24,530	72.7	24,540	74.2	22,790*		90	74.3	28,130	75.9	26,120*	77.4	24,260*
	110	68.9	20,990	70.5	20,990	72.0	21,010		100	72.4	23,700	73.9	23,710	75.3	23,310*
	120	66.7	18,080	68.3	18,080	69.8	18,100		110	70.3	20,150	71.9	20,150	73.3	20,170
230'	130	64.4	15,660	66.0	15,670	67.5	15,680	250'	120	68.3	17,240	69.8	17,240	71.2	17,250
	140	62.1	13,610	63.7	13,620	65.2	13,630		130	66.2	14,810	67.8	14,810	69.1	14,820
	150	59.8	11,860	61.4	11,870	62.8	11,880		140	64.1	12,760	65.6	12,760	67.0	12,780
	160	57.3	10,340	58.9	10,350	60.3	10,360		150	62.0	11,000	63.5	11,010	64.8	11,020
	170	54.9	9,010	56.4	9,020	57.8	9,030		160	59.8	9,480	61.3	9,490	62.6	9,500
	180	52.3	7,860	53.9	7,870	55.2	7,880		170	57.5	8,150	59.0	8,160	60.3	8,170
	190	49.7	6,830	51.2	6,840	52.5	6,850		180	55.2	6,980	56.7	6,990	57.9	7,000
	200	46.9	5,910	48.4	5,920	49.6	5,940		190	52.8	5,960	54.3	5,960	55.5	5,980
	210	44.0	5,100	45.5	5,110	46.6	5,120		200	50.4	5,030	51.8	5,040	53.0	5,060
	220	40.9	4,360	42.4	4,370	43.5	4,390		210	47.9	4,210	49.3	4,210	50.4	4,230
	230	37.6	3,710	39.1	3,720	40.1	3,740		220	45.2	3,470	46.6	3,480	47.7	3,500
									230	42.4	2,810	43.8	2,820	44.8	2,840
									240	39.5	2,210	40.8	2,220	41.8	2,240

	55	80.9	30,840*	-	-	-	-
	60	79.9	30,530*	-	-	-	-
	70	77.9	29,880*	79.5	27,100*	-	-
	80	75.8	29,190*	77.5	26,690*	79.0	24,610*
	90	73.8	28,540	75.4	26,250*	76.9	24,230*
	100	71.7	24,110	73.3	24,120	74.8	23,040*
240'	110	69.6	20,570	71.2	20,570	72.7	20,590
	120	67.5	17,660	69.1	17,660	70.5	17,670
	130	65.3	15,230	66.9	15,230	68.3	15,250
	140	63.1	13,180	64.7	13,190	66.1	13,200
	150	60.9	11,430	62.5	11,430	63.8	11,450
	160	58.6	9,900	60.1	9,910	61.5	9,930
	170	56.3	8,590	57.8	8,590	59.1	8,610
	180	53.8	7,420	55.3	7,430	56.6	7,440
	190	51.3	6,390	52.8	6,390	54.1	6,410
	200	48.7	5,470	50.2	5,470	51.4	5,490
	210	46.0	4,650	47.5	4,660	48.6	4,680
	220	43.2	3,910	44.6	3,920	45.7	3,940
	230	40.2	3,250	41.6	3,260	42.6	3,280
	240	37.0	2,660	38.3	2,670	39.3	2,690

60' Jib length							360°								
Boom length	Jib Radius (Feet)	5.0 Deg offset Boom Angle	Rating (Pounds)	15.0 Deg offset Boom Angle	Rating (Pounds)	25.0 Deg offset Boom Angle	Rating (Pounds)	Boom length	Jib Radius (Feet)	5.0 Deg offset Boom Angle	Rating (Pounds)	15.0 Deg offset Boom Angle	Rating (Pounds)	25.0 Deg offset Boom Angle	Rating (Pounds)
	43	80.9	28,920*	-	-	-	-								
	50	79.0	28,190*	-	-	-	-		45	80.8	28,710*	-	-	-	-
150'	60	76.2	27,190*	78.9	24,740*	-	-		50	79.5	28,220*	-	-	-	-
	70	73.4	26,160*	76.1	24,040*	78.6	21,560*		60	76.8	27,220*	79.4	24,690*	-	-
	80	70.5	25,280*	73.2	23,380*	75.7	20,000*		70	74.1	26,330*	76.7	24,110*	79.2	21,790*
	90	67.6	24,480*	70.2	22,750*	72.7	18,670*		80	71.4	25,470*	74.0	23,480*	76.4	20,320*
	100	64.6	23,780*	67.2	21,830*	69.6	17,500*		90	68.6	24,710*	71.2	22,890*	73.5	18,950*
	110	61.5	23,100*	64.1	20,370*	66.5	16,520*	160'	100	65.8	24,020*	68.3	22,290*	70.6	17,790*
	120	58.3	21,540	60.9	19,080*	63.2	15,660*			110	62.9	23,300*	65.4	20,920*	67.7
	130	55.0	19,130	57.6	18,020*	59.8	14,880*		120	59.9	21,120	62.4	19,670*	64.6	15,980*
	140	51.6	17,100	54.1	17,060*	56.3	14,230*		130	56.8	18,710	59.3	18,550*	61.4	15,170*
	150	47.9	15,360	50.4	15,370	52.5	13,700*		140	53.6	16,680	56.0	16,690	58.1	14,540*
									150	50.3	14,940	52.7	14,950	54.7	13,950*
									160	46.7	13,430	49.1	13,440	51.0	13,460



LOAD CHART

HC 165

**With 77SI Offset Tip Boom and 116,400 Pound Counterweight
#16HL Jib**

108,400 lb + 8,000 lb carbody counterweight							360°				ANSI B 30.5				
60' Jib length															
Boom length	Jib Radius (Feet)	5.0 Deg offset Boom Angle	28,710* Rating (Pounds)	15.0 Deg offset Boom Angle	24,100* Rating (Pounds)	25.0 Deg offset Boom Angle	18,150* Rating (Pounds)	Boom length	Jib Radius (Feet)	5.0 Deg offset Boom Angle	28,250* Rating (Pounds)	15.0 Deg offset Boom Angle	23,160* Rating (Pounds)	25.0 Deg offset Boom Angle	17,890* Rating (Pounds)
	46	81.0	28,710*	-	-	-	-		51	80.9	28,250*	-	-	-	-
	50	79.9	28,370*	-	-	-	-		60	78.9	27,540*	-	-	-	-
	60	77.4	27,410*	79.9	24,820*	-	-		70	76.6	26,750*	78.8	24,200*	80.9	22,160*
	70	74.8	26,500*	77.3	24,100*	79.6	22,130*		80	74.4	26,060*	76.5	23,690*	78.6	21,350*
	80	72.2	25,670*	74.7	23,590*	77.0	20,560*		90	72.0	25,320*	74.2	23,160*	76.2	20,030*
	90	69.6	24,880*	72.0	22,940*	74.3	19,210*		100	69.7	24,740*	71.9	22,720*	73.9	18,950*
170'	100	66.9	24,210*	69.3	22,410*	71.6	18,150*	200'	110	67.3	22,390*	69.5	22,220*	71.4	17,890*
	110	64.2	23,560*	66.6	21,450*	68.8	17,160*		120	64.9	19,490*	67.0	19,500*	69.0	17,080*
	120	61.4	20,710*	63.7	20,120*	65.9	16,270*		130	62.5	17,070*	64.6	17,080*	66.4	16,300*
	130	58.5	18,300*	60.8	18,310*	62.9	15,510*		140	59.9	15,030*	62.0	15,040*	63.9	15,050*
	140	55.5	16,260*	57.8	16,270*	59.8	14,810*		150	57.3	13,280*	59.4	13,290*	61.2	13,310*
	150	52.3	14,520*	54.6	14,520*	56.6	14,210*		160	54.6	11,760*	56.7	11,770*	58.5	11,790*
	160	49.1	13,010*	51.3	13,010*	53.3	13,030*		170	51.9	10,450*	53.9	10,460*	55.6	10,480*
	170	45.6	11,700*	47.9	11,710*	49.7	11,730*		180	49.0	9,290*	51.0	9,300*	52.6	9,320*
									190	45.9	8,270*	47.9	8,280*	49.5	8,290*
									200	42.7	7,370*	44.7	7,380*	46.2	7,400*
	48	80.8	28,530*	-	-	-	-		53	80.8	28,110*	-	-	-	-
	50	80.4	28,420*	-	-	-	-		60	79.3	27,580*	-	-	-	-
	60	77.9	27,470*	80.3	24,840*	-	-		70	77.1	26,900*	79.2	24,200*	-	-
	70	75.5	26,670*	77.9	24,210*	80.1	22,280*		80	74.9	26,160*	77.0	23,670*	79.0	21,580*
	80	73.0	25,850*	75.4	23,600*	77.6	20,810*		90	72.7	25,440*	74.8	23,200*	76.8	20,280*
	90	70.5	25,060*	72.8	23,080*	75.0	19,570*		100	70.5	24,770*	72.6	22,740*	74.5	19,130*
180'	100	67.9	24,410*	70.3	22,540*	72.4	18,400*		110	68.2	21,970*	70.3	21,970*	72.2	18,220*
	110	65.3	23,220*	67.6	21,960*	69.7	17,400*		120	65.9	19,070*	68.0	19,080*	69.8	17,270*
	120	62.7	20,330*	64.9	20,330*	67.0	16,570*		130	62.7	17,910*	64.2	17,920*	64.2	15,750*
	130	59.9	17,910*	62.2	17,920*	64.2	15,750*		140	57.1	15,870*	59.3	15,880*	61.3	15,070*
	140	54.2	14,130*	56.4	14,130*	58.3	14,150*		150	54.2	14,130*	56.4	14,130*	58.3	14,150*
	160	51.1	12,620*	53.3	12,630*	55.2	12,650*		160	51.1	12,620*	53.3	12,630*	55.2	12,650*
	170	48.0	11,310*	50.1	11,310*	51.9	11,330*		170	48.0	11,310*	50.1	11,310*	51.9	11,330*
	180	44.6	10,160*	46.7	10,170*	48.4	10,190*		180	44.6	10,160*	46.7	10,170*	48.4	10,190*
	49	81.0	28,420*	-	-	-	-		54	80.9	27,970*	-	-	-	-
	50	80.8	28,350*	-	-	-	-		60	79.7	27,630*	-	-	-	-
	60	78.4	27,480*	80.7	24,760*	-	-		70	77.6	26,930*	79.6	24,190*	-	-
	70	76.1	26,720*	78.4	24,200*	80.5	22,240*		80	75.5	26,250*	77.5	23,760*	79.4	21,710*
	80	73.7	25,940*	76.0	23,700*	78.1	21,050*		90	73.4	25,540*	75.4	23,270*	77.3	20,450*
	90	71.3	25,200*	73.6	23,090*	75.6	19,790*		100	71.2	24,900*	73.2	22,810*	75.1	19,380*
190'	100	68.9	24,580*	71.1	22,630*	73.2	18,670*		110	69.0	21,550*	71.0	21,550*	72.9	18,380*
	110	66.4	22,800*	68.6	22,190*	70.6	17,700*		120	66.8	18,650*	68.8	18,650*	70.6	17,510*
	120	63.8	19,900*	66.0	19,910*	68.0	16,790*		130	64.6	16,220*	66.5	16,230*	68.3	16,240*
	130	61.2	17,490*	63.4	17,500*	65.4	16,000*		140	62.3	14,170*	64.2	14,180*	66.0	14,200*
	140	58.6	15,450*	60.7	15,450*	62.7	15,360*		150	59.9	12,420*	61.9	12,430*	63.6	12,440*
	150	55.8	13,700*	58.0	13,710*	59.8	13,720*		160	57.5	10,910*	59.4	10,920*	61.1	10,930*
	160	53.0	12,190*	55.1	12,200*	56.9	12,220*		170	55.0	9,580*	56.9	9,590*	58.6	9,610*
	170	50.0	10,870*	52.1	10,880*	53.9	10,900*		180	52.5	8,420*	54.4	8,430*	56.0	8,440*
	180	46.9	9,730*	49.0	9,730*	50.7	9,750*		190	49.8	7,400*	51.7	7,410*	53.2	7,420*
	190	43.7	8,700*	45.7	8,710*	47.3	8,730*		200	47.1	6,480*	48.9	6,490*	50.4	6,510*
									210	44.2	5,670*	46.0	5,680*	47.4	5,700*
									220	41.1	4,930*	42.9	4,940*	44.2	4,960*

LOAD CHART

HC 165

With 77SI Offset Tip Boom and 116,400 Pound Counterweight
#16HL Jib

108,400 lb + 8,000 lb carbody counterweight 360° ANS​​I B 30.5

70' Jib length							
Boom length	Jib Radius (Feet)	5.0 Deg offset Boom Angle	5.0 Deg offset Rating (Pounds)	15.0 Deg offset Boom Angle	15.0 Deg offset Rating (Pounds)	25.0 Deg offset Boom Angle	25.0 Deg offset Rating (Pounds)
	52	80.9	21,300*	-	-	-	-
	60	79.1	20,740*	-	-	-	-
	70	76.8	19,950*	79.4	17,910*	-	-
	80	74.5	19,320*	77.1	17,350*	79.5	15,870*
	90	72.2	18,740*	74.8	16,890*	77.2	15,440*
	100	69.9	18,130*	72.4	16,510*	74.8	15,020*
190'	110	67.5	17,580*	70.0	16,110*	72.3	14,680*
	120	65.1	17,080*	67.6	15,600*	69.9	14,360*
	130	62.6	16,620*	65.1	15,130*	67.3	13,960*
	140	60.1	15,580	62.6	14,730*	64.8	13,320*
	150	57.5	13,830	59.9	13,840	62.1	12,790*
	160	54.8	12,320	57.2	12,330	59.3	12,310*
	170	52.1	11,000	54.4	11,010	56.5	11,030
	180	49.2	9,850	51.5	9,860	53.5	9,880
	190	46.1	8,830	48.4	8,840	50.4	8,860

	53	81.0	21,240*	-	-	-	-
	60	79.5	20,790*	-	-	-	-
	70	77.3	20,110*	79.8	17,920*	-	-
	80	75.1	19,390*	77.6	17,400*	79.9	15,860*
	90	72.9	18,830*	75.4	16,940*	77.7	15,520*
	100	70.7	18,230*	73.1	16,580*	75.4	15,120*
200'	110	68.4	17,700*	70.8	16,130*	73.1	14,730*
	120	66.1	17,210*	68.5	15,720*	70.7	14,420*
	130	63.7	16,780*	66.1	15,320*	68.3	14,100*
	140	61.3	15,170	63.7	14,870*	65.8	13,550*
	150	58.9	13,420	61.2	13,420	63.3	12,970*
	160	56.3	11,900	58.7	11,910	60.7	11,920
	170	53.7	10,580	56.0	10,590	58.0	10,610
	180	51.0	9,420	53.3	9,430	55.2	9,450
	190	48.2	8,400	50.4	8,410	52.3	8,430
	200	45.2	7,490	47.4	7,500	49.2	7,520

	55	80.9	21,110*	-	-	-	-
	60	79.9	20,840*	-	-	-	-
	70	77.8	20,100*	80.2	17,940*	-	-
	80	75.7	19,530*	78.0	17,440*	80.3	15,840*
	90	73.5	18,900*	75.9	17,040*	78.1	15,490*
	100	71.4	18,420*	73.7	16,630*	75.9	15,130*
	110	69.2	17,850*	71.6	16,200*	73.7	14,760*
	120	67.0	17,380*	69.3	15,860*	71.5	14,470*
210'	130	64.8	16,780	67.1	15,400*	69.2	14,160*
	140	62.5	14,730	64.7	14,740	66.8	13,740*
	150	60.1	12,980	62.4	12,990	64.4	13,010
	160	57.7	11,470	59.9	11,480	61.9	11,500
	170	55.2	10,140	57.4	10,150	59.4	10,170
	180	52.7	8,990	54.9	9,000	56.8	9,020
	190	50.0	7,960	52.2	7,970	54.0	7,990
	200	47.2	7,040	49.4	7,050	51.2	7,070
	210	44.3	6,230	46.5	6,240	48.2	6,260

Boom length	Jib Radius (Feet)	5.0 Deg offset Boom Angle	5.0 Deg offset Rating (Pounds)	15.0 Deg offset Boom Angle	15.0 Deg offset Rating (Pounds)	25.0 Deg offset Boom Angle	25.0 Deg offset Rating (Pounds)
	57	80.8	21,020*	-	-	-	-
	60	80.2	20,800*	-	-	-	-
	70	78.2	20,170*	80.5	17,880*	-	-
	80	76.2	19,590*	78.5	17,420*	80.6	15,770*
	90	74.1	18,980*	76.4	17,010*	78.6	15,500*
	100	72.1	18,500*	74.3	16,610*	76.4	15,210*
190'	110	70.0	17,920*	72.2	16,260*	74.3	14,820*
	120	67.8	17,470*	70.1	15,920*	72.1	14,510*
220'	130	65.7	16,360	67.9	15,550*	69.9	14,200*
	140	63.5	14,310	65.7	14,320	67.7	13,910*
	150	61.2	12,560	63.4	12,570	65.4	12,580
	160	58.9	11,040	61.1	11,050	63.1	11,070
	170	56.6	9,720	58.8	9,720	60.6	9,740
	180	54.2	8,550	56.3	8,560	58.2	8,580
	190	51.7	7,530	53.8	7,540	55.6	7,560
	200	49.1	6,610	51.2	6,620	52.9	6,640
	210	46.4	5,790	48.4	5,800	50.1	5,820
	220	43.5	5,060	45.5	5,070	47.2	5,090

	58	80.9	20,970*	-	-	-	-
	60	80.5	20,850*	-	-	-	-
	70	78.6	20,270*	80.8	17,900*	-	-
	80	76.6	19,650*	78.9	17,460*	81.0	15,780*
	90	74.7	19,050*	76.9	17,050*	79.0	15,520*
	100	72.7	18,540*	74.9	16,660*	76.9	15,230*
190'	110	70.7	18,070*	72.9	16,280*	74.9	14,910*
	120	68.6	17,570*	70.8	15,970*	72.8	14,560*
230'	130	66.5	15,970	68.7	15,620*	70.7	14,240*
	140	64.4	13,920	66.6	13,930	68.5	13,940
	150	62.3	12,160	64.4	12,170	66.3	12,190
	160	60.1	10,640	62.2	10,650	64.1	10,670
	170	57.9	9,320	59.9	9,330	61.8	9,350
	180	55.5	8,150	57.6	8,160	59.4	8,180
	190	53.2	7,120	55.2	7,130	57.0	7,150
	200	50.7	6,200	52.8	6,210	54.5	6,230
	210	48.2	5,390	50.2	5,400	51.9	5,420
	220	45.5	4,640	47.5	4,650	49.1	4,670
	230	42.7	3,980	44.7	3,990	46.2	4,020

	60	80.8	20,810*	-	-	-	-
	70	79.0	20,240*	-	-	-	-
	80	77.1	19,710*	79.2	17,460*	-	-
	90	75.2	19,110*	77.3	17,080*	79.3	15,430*
	100	73.3	18,650*	75.4	16,700*	77.4	15,190*
	110	71.3	18,110*	73.4	16,300*	75.4	14,920*
190'	120	69.3	17,630*	71.5	16,000*	73.4	14,580*
	130	67.3	15,530	69.4	15,540	71.4	14,310*
240'	140	65.3	13,490	67.4	13,490	69.3	13,510
	150	63.3	11,730	65.3	11,740	67.2	11,760
	160	61.2	10,220	63.2	10,220	65.0	10,240
	170	59.0	8,880	61.1	8,890	62.9	8,910
	180	56.8	7,710	58.8	7,720	60.6	7,740
	190	54.6	6,690	56.6	6,700	58.3	6,720
	200	52.2	5,760	54.2	5,770	55.9	5,790
	210	49.8	4,940	51.8	4,950	53.4	4,970
	220	47.3	4,210	49.3	4,220	50.9	4,240
	230	44.7	3,530	46.6	3,540	48.2	3,570
	240	42.0	2,930	43.9	2,950	45.3	2,970

LOAD CHART

HC 165

**With 77SI Offset Tip Boom and 116,400 Pound Counterweight
#16HL Jib**

108,400 lb + 8,000 lb carbody counterweight						360°					ANSI B 30.5				
80' Jib length															
Boom length	Jib Radius (Feet)	5.0 Deg offset Boom Angle	5.0 Deg offset Rating (Pounds)	15.0 Deg offset Boom Angle	15.0 Deg offset Rating (Pounds)	25.0 Deg offset Boom Angle	25.0 Deg offset Rating (Pounds)	Boom length	Jib Radius (Feet)	5.0 Deg offset Boom Angle	5.0 Deg offset Rating (Pounds)	15.0 Deg offset Boom Angle	15.0 Deg offset Rating (Pounds)	25.0 Deg offset Boom Angle	25.0 Deg offset Rating (Pounds)
	56	80.9	16,550*	-	-	-	-								
	60	80.0	16,300*	-	-	-	-		61	80.8	16,310*	-	-	-	-
	70	77.9	15,600*	80.7	13,680*	-	-		70	79.1	15,790*	-	-	-	-
	80	75.8	15,020*	78.6	13,260*	-	-		80	77.2	15,220*	79.7	13,300*	-	-
	90	73.7	14,470*	76.4	12,760*	79.0	11,270*		90	75.3	14,700*	77.8	12,920*	80.1	11,330*
	100	71.6	14,000*	74.3	12,310*	76.8	10,920*		100	73.4	14,200*	75.9	12,480*	78.1	10,990*
200'	110	69.4	13,490*	72.1	11,870*	74.6	10,600*		110	71.5	13,770*	73.9	12,080*	76.2	10,670*
	120	67.2	12,980*	69.8	11,470*	72.3	10,340*		120	69.5	13,340*	71.9	11,670*	74.2	10,420*
	130	64.9	12,480*	67.6	11,080*	70.0	10,060*	230'	130	67.5	12,960*	69.9	11,320*	72.1	10,180*
	140	62.6	12,000*	65.3	10,760*	67.6	9,860*		140	65.5	12,480*	67.9	10,990*	70.1	9,970*
	150	60.3	11,600*	62.9	10,450*	65.2	9,660*	150	63.4	12,030*	65.8	10,720*	67.9	9,740*	
	160	57.9	11,200*	60.5	10,190*	62.8	9,450*	160	61.3	10,780*	63.7	10,440*	65.8	9,560*	
	170	55.4	10,700*	58.0	9,970*	60.2	9,290*	170	59.2	9,440*	61.5	9,450*	63.6	9,380*	
	180	52.8	9,550*	55.4	9,560*	57.6	9,150*	180	57.0	8,280*	59.3	8,290*	61.3	8,320*	
	190	50.2	8,520*	52.7	8,530*	54.8	8,550*	190	54.7	7,250*	57.0	7,260*	59.0	7,280*	
	200	47.4	7,600*	49.9	7,610*	52.0	7,640*	200	52.4	6,330*	54.7	6,340*	56.6	6,370*	
								210	50.0	5,510*	52.2	5,520*	54.2	5,550*	
								220	47.5	4,770*	49.7	4,780*	51.6	4,800*	
								230	44.9	4,100*	47.1	4,120*	48.9	4,140*	
	57	81.0	16,490*	-	-	-	-								
	60	80.4	16,280*	-	-	-	-								
	70	78.4	15,710*	-	-	-	-								
	80	76.3	15,130*	79.0	13,280*	-	-								
	90	74.3	14,550*	76.9	12,850*	79.4	11,290*		62	80.9	16,250*	-	-	-	-
	100	72.2	14,090*	74.8	12,350*	77.3	10,940*		70	79.5	15,800*	-	-	-	-
	110	70.1	13,600*	72.7	11,950*	75.1	10,640*		80	77.6	15,260*	80.0	13,270*	-	-
	120	68.0	13,150*	70.6	11,560*	73.0	10,360*		90	75.8	14,760*	78.2	12,950*	80.4	11,340*
210'	130	65.9	12,640*	68.4	11,180*	70.8	10,130*		100	73.9	14,270*	76.3	12,590*	78.5	11,010*
	140	63.7	12,160*	66.2	10,840*	68.5	9,900*		110	72.1	13,840*	74.4	12,140*	76.6	10,710*
	150	61.4	11,750*	63.9	10,540*	66.2	9,670*		120	70.2	13,430*	72.5	11,740*	74.7	10,470*
	160	59.1	11,350*	61.6	10,280*	63.9	9,490*	240'	130	68.3	13,050*	70.6	11,420*	72.7	10,190*
	170	56.8	10,280*	59.2	10,020*	61.4	9,320*		140	66.3	12,630*	68.6	11,080*	70.7	9,990*
	180	54.3	9,110*	56.8	9,120*	58.9	9,140*	150	64.3	11,870*	66.6	10,790*	68.7	9,780*	
	190	51.8	8,090*	54.3	8,100*	56.4	8,120*	160	62.3	10,340*	64.6	10,350*	66.7	9,570*	
	200	49.2	7,170*	51.6	7,180*	53.7	7,200*	170	60.2	9,020*	62.5	9,030*	64.5	9,050*	
	210	46.5	6,350*	48.9	6,360*	50.9	6,390*	180	58.1	7,850*	60.4	7,860*	62.4	7,880*	
								190	56.0	6,810*	58.2	6,820*	60.2	6,840*	
								200	53.8	5,890*	56.0	5,910*	57.9	5,930*	
								210	51.5	5,070*	53.7	5,080*	55.6	5,110*	
								220	49.1	4,330*	51.3	4,340*	53.1	4,370*	
								230	46.7	3,670*	48.8	3,680*	50.6	3,700*	
								240	44.1	3,060*	46.2	3,080*	47.9	3,100*	
	59	80.9	16,420*	-	-	-	-								
	60	80.7	16,300*	-	-	-	-								
	70	78.8	15,750*	-	-	-	-								
	80	76.8	15,170*	79.4	13,260*	-	-								
	90	74.8	14,630*	77.4	12,880*	79.8	11,310*								
	100	72.8	14,180*	75.4	12,420*	77.7	10,970*								
	110	70.8	13,690*	73.3	12,010*	75.7	10,670*								
	120	68.8	13,290*	71.3	11,590*	73.6	10,420*								
220'	130	66.7	12,830*	69.2	11,280*	71.5	10,160*								
	140	64.6	12,350*	67.1	10,920*	69.3	9,930*								
	150	62.5	11,930*	64.9	10,620*	67.1	9,730*								
	160	60.3	11,170*	62.7	10,340*	64.9	9,520*								
	170	58.0	9,850*	60.4	9,860*	62.6	9,380*								
	180	55.7	8,680*	58.1	8,690*	60.2	8,710*								
	190	53.3	7,660*	55.7	7,670*	57.8	7,690*								
	200	50.9	6,730*	53.2	6,750*	55.2	6,770*								
	210	48.3	5,920*	50.7	5,930*	52.6	5,950*								
	220	45.7	5,180*	48.0	5,190*	49.8	5,220*								



Warning

This rating chart is invalid if the crane has been modified or altered by use of other than GENUINE AMERICAN PARTS as such modifications or alterations may affect its capacity or safe operation. See American Crane Corporation Service Bulliten #259.

Ratings in this chart are in POUNDS and do not exceed the percentage of tipping specified for this crane by ANSI B30.5. All ratings require that the crane be standing level on a firm uniformly supporting surface.

Do not lift loads in excess of those shown on this chart. Lifting loads in excess of those shown or operation not in accordance with good operating practice, including limitations shown on page 3499 of Operator's Manual, can cause tipping, structural damage or catastrophic failure.

Asterisk (*) areas on this chart indicate ratings which are limited by strength of material or factors other than stability (tipping).

„JIB RADIUS IN FEET“ is the horizontal distance at ground level from the crane centerline of rotation to a vertical line through the center of gravity of the suspended load.

When using the main boom fall with jib in place, the main fall ratings must be reduced by the jib effective weight shown on the jib rating chart plus twice the weight of all suspended blocks, slings, rope, etc., at the jib fall. See Appendix A.

When using the main boom fall with boom tip extension in place, the main fall ratings must be reduced by the weight of the boom tip extension plus twice the weight of all suspended blocks, slings, rope, etc., at the boom tip extension fall. See Appendix A.

Blocks, slings, buckets and other load carrying devices are considered part of the load. The weight of standard hoisting ropes for the rating at a given radius has been calculated as part of the boom point load and need not be considered in determining net allowable loads. See Appendix A.

Ratings shown on this chart make no allowance for such factors as out of plumb loads, wind, poor soil conditions, improper inflation of rubber tires and dynamic effects due to excessive operating speeds. The user (operator) must exercise judgement to make allowance for these conditions. See page 3499 of Operator's Manual for detailed information.

No account is taken of the wind force on the load. This effect, which can be substantial for loads with large surface areas, must be considered by the user. In any wind it is strongly recommended that taglines be used to control the load.

BOOM HOIST LINE is 14 parts of 7/8 inch diameter EIPS wire rope with a minimum breaking strength of 79,600 pound. PENDANT SUSPENSION LINE is 4 parts of 1.375 inch diameter EEIPS wire rope with a minimum breaking strength of 211,000 pound. JIB BACKSTAY LINE AND FRONTSTAY LINES are 2 parts of 0.875 inch diameter wire rope with a minimum breaking strength of 69,200 pound.

WHIP LINE – 1.125 inch diameter EIPS wire rope with a minimum breaking strength of 130,000 pound or ALTERNATE WHIP LINE (ROTATION RESISTANT) – 1.125 inch diameter BRIDON ENDURANCE DYFORM 34LR Grade 2160 wire rope with a minimum breaking strength of 167,200 pound.

ERECTION

Erection „OVER THE END“ is with the boom over the idler end with idler tumblers blocked (See operator's manual for blocking instructions). Erection „OVER THE SIDE“ is with the boom 90° to the sideframes and with the side frames extended. Blocks, slings and other load carrying devices must be on the ground during erection.

LOAD HOISTING INFORMATION - 1.125 inch diameter EIPS wire rope			
MAXIMUM LIFTING CAPACITY - LBS.	MINIMUM PARTS OF LINE	MAXIMUM HOISTING DISTANCE - FT	
		MAIN (FRONT)	AUX. (REAR)
32,000	1	1,312	1,312

LOAD HOISTING INFORMATION (ROTATION RESISTANT LOAD LINE)			
1.125 inch diameter BRIDON ENDURANCE DYFORM 34LR Grade 2160 wire rope			
MAXIMUM LIFTING CAPACITY - LBS.	MINIMUM PARTS OF LINE	MAXIMUM HOISTING DISTANCE - FEET	
		MAIN (FRONT)	AUX. (REAR)
32,000	1	1,312	1,312

77SI OFFSET TIP BOOM COMPOSITION CHART							
BOOM LENGTH (METERS)	BOOM LENGTH (FEET)	BOOM SECTIONS					
		9.1 M 30' 77SI INNER	3.0 M 10' 77S CENTER	6.1 M 20' 77S CENTER	15.2 M 50' 77S CENTER	5.9 M 19.5' 77HL OUTER	9.1 M 30' 77LA OFFSET TIP
24.4 M	80	1	0	0	0	1	1
27.4 M	90	1	1	0	0	1	1
30.5 M	100	1	0	1	0	1	1
33.5 M	110	1	1	1	0	1	1
36.6 M	120	1	0	2	0	1	1
39.6 M	130	1	0	0	1	1	1
42.7 M	140	1	1	0	1	1	1
45.7 M	150	1	0	1	1	1	1
48.8 M	160	1	1	1	1	1	1
51.8 M	170	1	0	2	1	1	1
54.9 M	180	1	0	0	2	1	1
57.9 M	190	1	1	0	2	1	1
61.0 M	200	1	0	1	2	1	1
64.0 M	210	1	1	1	2	1	1
67.1 M	220	1	0	2	2	1	1
70.1 M	230	1	0	0	3	1	1
73.2 M	240	1	1	0	3	1	1
76.2 M	250	1	0	1	3	1	1
79.2 M	260	1	1	1	3	1	1
82.3 M	270	1	0	2	3	1	1

77SI OFFSET TIP BOOM MAXIMUM BOOM & JIB SELF-ERECTION DATA				
	OVER THE END		OVER THE SIDE	
	BOOM LENGTH (FT)	JIB LENGTH (FT)	BOOM LENGTH (FT)	JIB LENGTH (FT)
	#16HL JIB	270 260 250 240	0 0 60 80	240 230 220

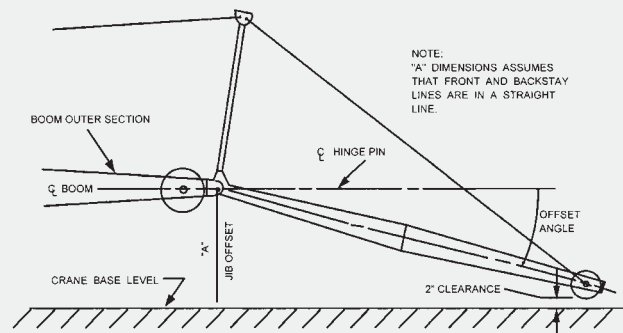

#16HL JIB COMPOSITION CHART								
JIB LENGTH (FEET)	20' INNER	10' CENTER	20' CENTER	20' OUTER	EFF. JIB WEIGHT (POUNDS)	JIB OFFSET \"A\" IN FEET		
						5°	15°	25°
40	1	0	0	1	1,500	4'-10"	10'- 2"	15'- 1"
50	1	1	0	1	2,050	5'- 8"	12'- 1"	18'- 3"
60	1	0	1	1	2,600	6'- 8"	13'-10"	21'- 2"
70	1	1	1	1	3,150	7'- 1"	15'-10"	24'- 4"
80	1	0	2	1	3,700	7'- 9"	17'- 8"	27'- 4"

Hydraulic Crawler Crane

Maximum lifting capacity: 165 tons.

Boom Systems

77SI Tubular Boom with Offset Tip

- 270 ft maximum boom length.
- 320 ft (240 ft + 80 ft) maximum boom and jib combination length.
- 77SI tubular chord boom, pin connected.
- 30 ft inner, 19'5" outer base and 30 ft outer and 10 / 20 / 50 ft available inserts provide boom compositions in 10 ft increments from 80 ft to 270 ft.

77SI Tubular Boom with Hammerhead

- 240 ft maximum boom length.
- 300 ft (220 ft + 80 ft) maximum boom and jib combination length.
- 77SI tubular chord boom, pin connected.
- 30 ft inner, 19'5" outer base and hammerhead and 10/20/50 ft available inserts provide boom compositions in 10 ft increments from 50 ft to 240 ft.

58ABSH Angle Boom

- Consult factory for details.

Robust engine

- Cummins QSC8.3 diesel engine supplies 310 HP (231 kW) @ 2000 rpm, 506 cu. in. displacement, 112 gallon fuel capacity.

Environmental operator's cab

- Designed to provide excellent viewing range and quiet, comfortable operation.
- 37 in. wide cab has wide curved windows on both top and bottom.
- Easy-to-operate modular and ergonomically designed controls reduce operator fatigue and increase productivity.
- Load Moment Indicator with interactive screen features a shockless stop system. Operator can select from three display modes: loaded condition diagram, rated lifting curve, and rated lifting load table.
- Adjustable operator's seat, radio, air conditioner, overhead window, sun visor, fan, overhead and front wipers, and drum rotation indicators standard.

Heavy duty carbody and crawlers

- Fabricated steel carbody is deep box constructed with square axles for the crawler side frames. Precision machined top supports anti-friction swing circle and multiple pass hydraulic swivel joint.
- Crawlers have high alloy steel tumbler yokes and rigid fabricated structures with built-in sealed automatic lubrication system.
- 42" crawler shoes.
- Travel mechanism is set within shoe width.
- Side frames extended or retracted by cylinders inside the carbody.
- Two travel speed settings – 0.55 / 0.37 mph.
- 30 % (17°) gradeability.

Powerful, high-speed hoist system

- Two identical independent main and auxiliary load hoisting drums provide ample lifting power. Drums are grooved for 1-1/8 in. diameter rope. Max. line speed is 540 fpm, max. single line pull is 54,060 lb. Rated single line pull is 40,850 lb. Freefall on main and auxiliary drums.
- Each drum, including optional third, has power up/down. Load hoists are further controllable in stepless mode.
- Ample work space in front of drums allows easy access for cable installation and maintenance.
- External contracting brake.
- Internal expanding band clutch.

Smooth swing

- Separate swing circuit
- 2.0 rpm swing speed.

High capacity, dependable hydraulic system

- Open circuit system has 2 variable displacement piston pumps which supply power to the travel and hoisting functions, 3 gear pumps provide power for swing, hydraulic cylinders and pilot pressure.
- Hydraulic reservoir with 88.5 gallons capacity and 10 micron filtration. System capacity is 132 gallons.
- Component working range is between -4 and 203° F.

Seven piece removable counterweight

- 7 piece pin connected counterweight can be assembled or disassembled easily within minutes.
- Hydraulic counterweight removal system is standard and makes the HC165 one of the most transportable cranes in its class.
- Moves on 8 trucks with 240 ft 77SI offset tip boom and 80 ft of 16HL jib. At 11 ft 6-3/4 in. wide and 11 ft 5-3/4 in. high, the basic HC165 will transport on a standard lowboy trailer.

Options include:

- Third drum – machine mounted
- Third drum – boom inner mounted.
- Single sheave extension.
- 16HL tubular jib – 32,000 lb (77SI tubular boom only).
- #15 angle jib – 30,000 lb (58ABSH angle boom only).
- Optional 108,400 pound of upper and 8,000 pound of carbody counterweight.

HOIST DRUM PERFORMANCE

HC 165

MAIN AND AUXILIARY HOIST – 1 1/8” DIAMETER ROPE							
Rope Layer	High Range			Low Range		Total Rope Length	
	Line Speed Feet Per Minute	Single Line Pull	Line Speed Feet Per Minute	Single Line Pull			
1st*	358	27.030	179	54.060	153		
2nd*	389	24.910	194	49.850	313		
3rd*	419	23.015	210	46.230	493		
4th*	450	21.560	225	43.100	678		
5th*	480	20.195	240	40.390	883		
6th*	510	18.980	255	37.985	1.093		
7th**	540	17.925	269	35.845	1.325		
8th**	571	16.975	285	33.930	1.560		
9th**	601	16.115	301	32.230	1.817		

3RD DRUM WITH FREE FALL				3RD DRUM WITHOUT FREE FALL			
Rope Layer	Machine Mounted			Rope Layer	Boom Mounted – Braden CH210		
	Line Speed Feet Per Minute	Single Line Pull	Total Rope Length		Line Speed Feet Per Minute	Single Line Pull	Total Rope Length
1st*	129	37.655	64	1st*	193	19.100	116
2nd*	140	34.725	129	2nd*	210	17.530	242
3rd*	150	32.210	204	3rd*	227	16.200	379
4th*	161	30.050	278	4th*	244	15.050	526
5th*	172	28.155	364	5th*	262	14.060	683
6th*	183	26.480	449	6th**	279	13.190	851
7th*	194	25.000	545				
8th**	205	23.680	640				
9th**	216	22.465	747				

Remarks

- * Working Layers
- ** Storage Layers

TRANSPORT EXAMPLE FOR HC 165

HC 165

240' 77" SH Boom with Offset Tip 80' 16HL jib

Loads required as follows: (weights shown do **NOT** include blocking or tie-down material)

LOAD NO. 1

Crawler side frame	37,000 lb
2 x 20' 16HL center sections @ 510 lb each	1,020 lb
TOTAL LOAD	38,020 lb

LOAD NO. 2

Crawler side frame	37,000 lb
Basic 40' of 16HL Jib	3,060 lb
TOTAL LOAD	40,060 lb

LOAD NO. 3

2 x counterweights @ 9,200 lb each	18,400 lb
1 x 50' boom center section	4,500 lb
TOTAL LOAD	22,900 lb

LOAD NO. 4

2 x counterweights @ 11,200 lb each	22,400 lb
1 x 50' boom center section	4,500 lb
TOTAL LOAD	26,900 lb

LOAD NO. 5

2 x counterweights @ 11,200 lb each	22,400 lb
1 x 50' boom center section	4,500 lb
TOTAL LOAD	26,900 lb

LOAD NO. 6

Base counterweight	39,000 lb
1 x 20' boom (outer base)	2,900 lb
TOTAL LOAD	41,900 lb

LOAD NO. 7

Miscellaneous, Block, Ball, Pendants, etc.	12,000 lb
1 x 30' offset tip	5,300 lb
1 x 10' boom center section	1,000 lb
TOTAL LOAD	18,300 lb

LOAD NO. 8

Upperworks and Carbody:

- a) Transport system
- b) Boom inner section and boom stops
- c) Boom hoist rope
- d) Wire rope on main and auxiliary drums

TOTAL WEIGHT OF UPPER, etc.	94,000 lb
--	------------------

A large rectangular area with horizontal lines, intended for taking notes. The lines are evenly spaced and cover the majority of the page's width and height.

www.terexcranes.com

Effective Date: January 2011.

Product specifications and prices are subject to change without notice or obligation. The photographs and/or drawings in this document are for illustrative purposes only. Refer to the appropriate Operator's Manual for instructions on the proper use of this equipment. Failure to follow the appropriate Operator's Manual when using our equipment or to otherwise act irresponsibly may result in serious injury or death. The only warranty applicable to our equipment is the standard written warranty applicable to the particular product and sale and Terex makes no other warranty, express or implied. Products and services listed may be trademarks, service marks or trade-names of Terex Corporation and/or its subsidiaries in the USA and other countries. All rights are reserved. Terex® is a registered trademark of Terex Corporation in the USA and many other countries.

Copyright 2011 Terex Corporation

Terex Cranes, Global Marketing, Dinglerstraße 24, 66482 Zweibrücken, Germany
Tel. +49 (0) 6332 830, Email: info.cranes@terex.com, www.terexcranes.com

Brochure Reference: TC-DS-I-E-HC165-01/11



WORKS FOR YOU.™