

Specifications

Hydraulic Lattice Boom Crawler Crane

LS-208H

75-Ton (68 metric ton)

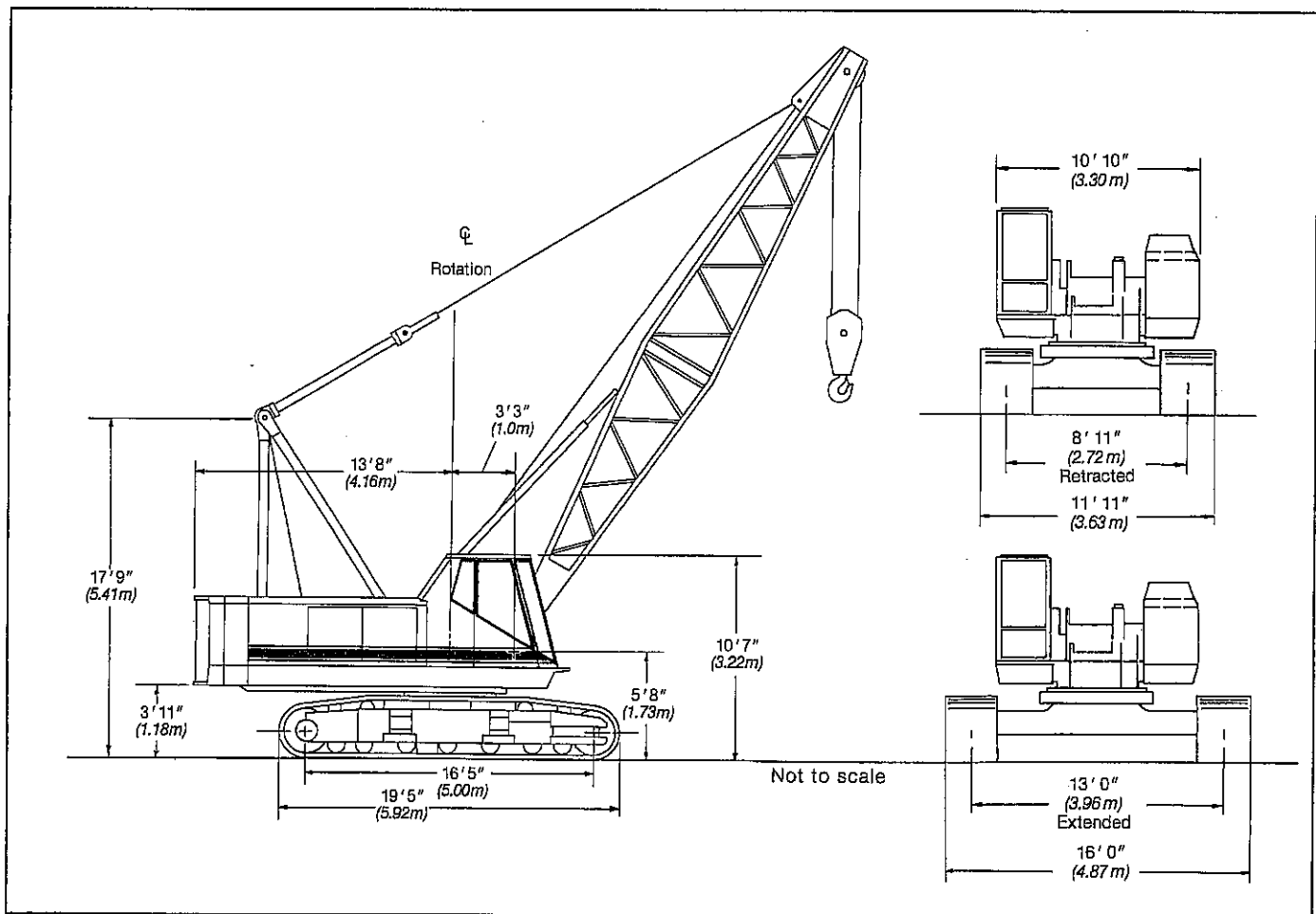

General dimensions	Feet	meters
Basic boom length	40' 0"	12.19
Overall width side frames extended - 36" (.91 m) track shoes	16' 0"	4.87
Overall width side frames retracted - 36" (.91 m) track shoes	11' 11"	3.63
Overall width side frames removed (axles in-line with truck - catwalks folded)	10' 10"	3.30
Minimum ground clearance	6' 16"	0.40

General dimensions	Feet	meters
Ground clearance - cwt. "A"	3' 11"	1.19
Ground clearance - cwt. "AB"	3' 11"	1.19
Overall width of counterweight	10' 2"	3.09
Tailswing of counterweight "A"	13' 6"	4.10
Tailswing of counterweight "AB"	13' 8"	4.16
Overall width of upper (catwalks folded)	10' 10"	3.30
Overall height for transport, gantry lowered	11' 2"	3.40

LS-208H Machine Transport Weights - approximate

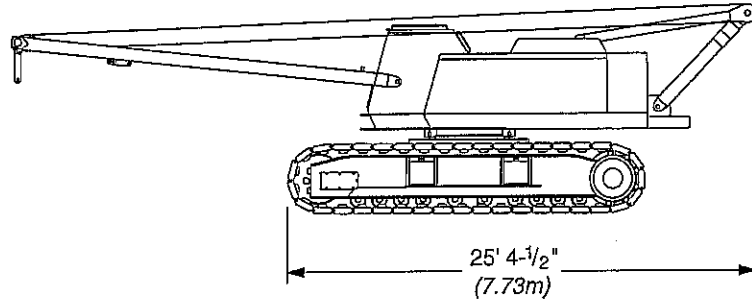
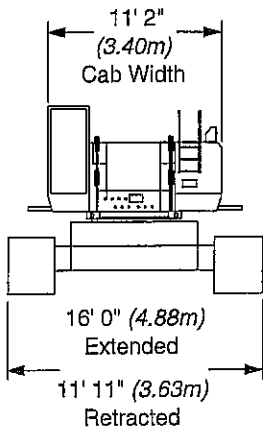

Assembly Weight - as shown
85,250 lbs. (38 669 kg) w/Live Mast and rope on one drum
82,550 lbs. (37 445 kg) w/o Live Mast and rope on one drum

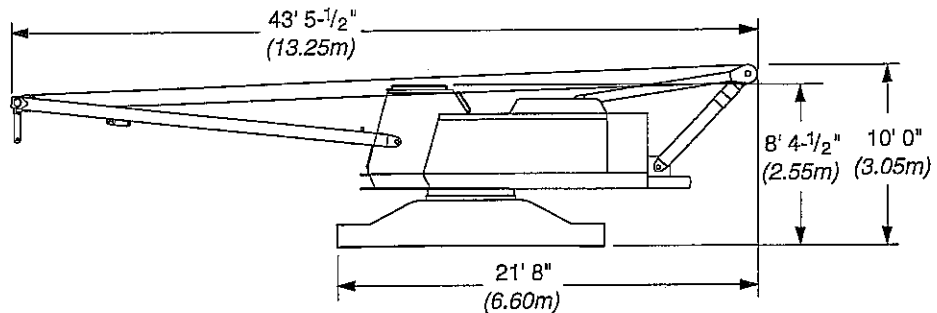
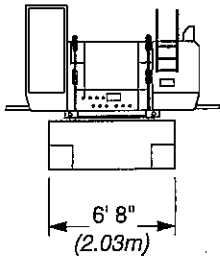

Upper & Carbody Shipping Weight
48,500 lbs. (22 000 kg) w/Live Mast and rope on one drum
45,800 lbs. (20 775 kg) w/o Live Mast and rope on one drum
4' 11" (1.50m)

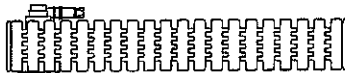
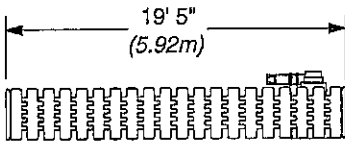

Tread Member w/36" (.91m) Shoes
18,400 lbs. (8 346 kg) Each



"A" Upper Counterweight
19,600 lbs. (8 891 kg)



"B" Upper Counterweight
20,100 lbs. (9 117 kg)

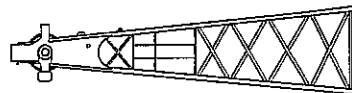
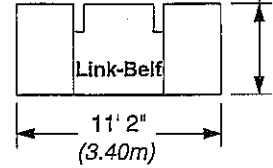

20' (6.10m) Peak Section
2,420 lbs. (1 098 kg) Tube Boom
3,220 lbs. (1 461 kg) Angle Boom

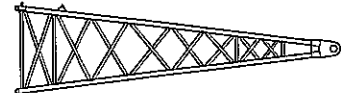

20' (6.10m) Base Section
1,840 lbs. (835 kg) Tube Boom
2,525 lbs. (1 145 kg) Angle Boom



20' (6.10m) Basic Jib Assembly
1,120 lbs. (508 kg) Tube Jib
1,700 lbs. (771 kg) Angle Jib



Front Mount Third Drum
1,265 lbs. (574 kg) w/Rope

Optional Boom Sections	Weight	Cross Section Size
10' (3.05 m) tube boom extension	685 lbs. (310 kg)	54" (1.37 m) wide x 44" (1.12 m) deep
20' (6.10 m) tube boom extension	1,090 lbs. (494 kg)	54" (1.37 m) wide x 44" (1.12 m) deep
30' (9.14 m) tube boom extension	1,500 lbs. (680 kg)	54" (1.37 m) wide x 44" (1.12 m) deep
10' (3.05 m) angle boom extension	1,000 lbs. (453 kg)	48" (1.22 m) wide x 48" (1.22 m) deep
20' (6.10 m) angle boom extension	1,640 lbs. (743 kg)	48" (1.22 m) wide x 48" (1.22 m) deep
30' (9.14 m) angle boom extension	2,350 lbs. (1 065 kg)	48" (1.22 m) wide x 48" (1.22 m) deep

Machine Working Weights - approximate

Complete basic machine with Mitsubishi 6D24-TEB diesel engine, turntable bearing, 36" (.91 m) wide track shoes, hydraulic independent swing and travel, main operating drums and boomhoist, 40' (12.19 m) angle boom, w/o live mast, no bucket or hookblock but with 295' (89.9 m) of 1" (25.4 mm) dia. dragline inhaul and hoist rope.	
With 39,700 lb. (18 008 kg) counterweight "AB"	131,700 lbs. (59 739 kg)

Performance Specifications

Wire rope and rope drum data

Main load hoist wire rope length – using 1" (25.4 mm) diameter wire rope

Parts of line	Boom lengths													
	40' (12.19 m)		50' (15.24 m)		60' (18.29 m)		70' (21.34 m)		80' (24.38 m)		90' (27.43 m)		100' (30.48 m)	
	Feet	meters	Feet	meters	Feet	meters	Feet	meters	Feet	meters	Feet	meters	Feet	meters
1	105	32.00	125	38.10	145	44.20	165	50.29	185	56.39	205	62.48	225	68.58
2	150	45.72	180	54.86	210	64.01	240	73.15	270	82.30	300	91.44	330	100.58
3	195	59.44	235	71.63	275	83.82	315	96.01	355	108.20	395	120.40	435	132.59
4	240	73.15	290	88.39	340	103.63	390	118.87	440	134.11	490	149.35	540	164.59
5	285	86.87	345	105.16	405	123.44	465	141.73	525	160.02	585	178.31	645	196.60
6	330	100.58	400	121.92	470	143.26	540	164.59	610	185.93	680	207.26	750	228.60
7	375	114.30	455	138.68	535	163.07	615	187.45	695	211.84	775	236.22	855	260.60

Parts of line	Boom lengths									
	110' (33.53 m)		120' (36.58 m)		130' (39.62 m)		140' (42.67 m)		150' (45.72 m)	
	Feet	meters	Feet	meters	Feet	meters	Feet	meters	Feet	meters
1	245	74.68	265	80.77	285	86.87	305	92.96	325	99.06
2	360	109.73	390	118.87	420	128.02	450	137.16	480	146.30
3	475	144.78	515	156.97	555	169.16	595	181.36	635	193.55
4	590	179.83	640	195.07	690	210.31	740	225.55	790	240.79
5	705	214.88	765	233.17	825	251.46	885	269.75	945	288.04
6	820	249.94	890	271.27						
7	935	284.99								

Dragline or clamshell wire rope lengths – using one part of line

Attachments	Function	Boom Lengths									
		40' (12.19 m)		50' (15.24 m)		60' (18.29 m)		70' (21.34 m)		80' (24.38 m)	
		Feet	meters	Feet	meters	Feet	meters	Feet	meters	Feet	meters
Clamshell	Holding	110	33.53	130	39.62	150	45.72	170	51.82	190	57.91
		160	48.77	180	54.86	200	60.96	220	67.06	240	73.16
Dragline	Hoist	110	33.53	130	39.62	150	45.72	170	51.82	190	57.91
		65	19.81	75	22.86	85	25.90	95	28.96	105	32.00

Drum wire rope capacities:

Wire rope layer	Front or rear drum - 18-11/16" (0.48 m) root diameter grooved lagging, 1" (25.4 mm) wire rope				Front mounted third drum - 12-3/4" (0.32 m) root diameter smooth lagging, 5/8" (16 mm) wire rope				Boomhoist drum - 10-11/16" (0.27 m) root diameter grooved lagging, 5/8" (16 mm) wire rope			
	Rope per layer		Total wire rope		Rope per layer		Total wire rope		Rope per layer		Total wire rope	
	Feet	meters	Feet	meters	Feet	meters	Feet	meters	Feet	meters	Feet	meters
1	96	29.2	96	29.2	69	21.0	69	21.0	45.9	14.0	45.9	14.0
2	105	32.0	201	61.3	76	23.2	146	44.5	50.6	15.4	96.5	29.4
3	115	35.1	316	96.3	82	25.0	229	69.8	54.7	16.7	151.2	46.1
4	125	38.1	441	134.4	89	27.1	318	96.9	59.7	18.2	210.6	64.2
5	135	41.1	576	175.6	96	29.3	414	126.2	63.7	19.4	274.3	83.6
6	144	43.9	720	219.5					68.2	20.8	342.5	104.4
7	154	46.9	875	266.7					72.5	22.1	415.0	126.5

LS-208H Load Hoisting Performance

Available line speed and line pull - based on Mitsubishi 6D24-TEB at 2,000 rpm full load speed.

Line pulls are not based on wire rope strength. See wire rope chart for maximum permissible single part of line working loads.

Front or Rear Drum: Line speeds and pulls

18-11/16" (.47 m) Root Dia. - 1" dia. rope													
Single line pull		First layer speed				Fourth layer speed				Sixth layer speed			
		Low		High		Low		High		Low		High	
lbs.	kg	fpm	m/min	fpm	m/min	fpm	m/min	fpm	m/min	fpm	m/min	fpm	m/min
1,000	454	92	28	184	56	121	37	240	73	141	43	279	85
5,000	2 268	92	28	184	56	121	37	240	73	141	43	279	85
10,000	4 536	92	28	184	56	121	37	240	73	141	43	279	85
15,000	6 804	92	28	184	56	121	37	240	73	141	43	259	79
20,000	9 072	92	28	184	56	112	34	207	63	112	34	210	64
29,500	12 474	75	23	148	45	66	20	128	39	52	16	108	33

Wire rope: size, type and working strength

Wire rope application	Size: diameter		Type	Max. permissible load	
	inches	mm		lbs.	kg
Main hoist	1	25	N	29,500	13 381
Auxiliary hoist	1	25	RB	17,520	7 947
Boomhoist	5/8	16	W	11,700	5 307
Third drum	5/8	16	N	11,700	5 307
Boom pendants	1-1/4	32	N	n/a	n/a
Jib pendants	3/4	19	N	n/a	n/a

Third drum - Front mounted:

Line speeds and pulls

Rope Layer	12-3/4" (.32 m) Root Dia.			
	fpm	m/min	pounds	kg
1	210	64	9,219	4 182
2	230	70	8,431	3 824
3	250	76	7,767	3 523
4	269	82	7,200	3 266
5	289	88	6,710	3 044

Wire rope: types available

- Type "RB" – 18 x 19 rotation resistance, extra extra improved plow steel, preformed, right lay, regular lay, swaged.
- Type "N" – 6 X 25 (6 X 19 class), filler wire, extra improved plow steel, preformed, independent wire rope center, right lay, regular lay.
- Type "W" – 6 X 26 (6 X 19 class), extra improved plow steel, preformed, independent wire rope center, right lay, alternate lay.

Crawler Lower

Lower frame

All welded, box construction, precision machined; 13' (3.96 m) extended or 8' 11" (2.72 m) retracted gauge X 19' 5" (5.92 m) track length.

Turntable bearing

Outer race is bolted to upper frame, inner race with internal ring gear is bolted to lower frame.

Crawler side frames

All welded, precision machined and removable; hydraulically extended or retracted by a cylinder mounted inside the lower frame.

Track drive sprockets and idler wheels

Cast steel, heat treated; sealed for lifetime lubrication.

Track rollers

Ten per side. Tractor type, oil filled for lifetime lubrication.

Track carrier rollers

Three tractor type rollers mounted on top of each crawler side frame. Oil filled for lifetime lubrication.

Tracks

Heat treated, self cleaning, multiple hinged track shoes joined by one piece full floating pins; 50 shoes per side frame. Standard shoes 36" (.91 m) wide.

Track tension adjustment - Track adjusted by hydraulic cylinders at the idler block. Tracks automatically release during excessive tension condition.

Independent travel & Steering

Axial piston motor with reduction gear is located at inner drive end of each crawler side frame. Each track is driven simultaneously or individually for straight-line, gradual turn, or pivot turn. The tracks can be counter-rotated for spin turns.

Brakes - Spring applied, hydraulically released multiple disc brakes are applied automatically when the control lever is in the neutral position.

Two speed travel- high - 1.0 mph (1.7 km/h)
- low - 0.6 mph (1 km/h)

Gradeability - 30%

Ground bearing pressure

Track shoes		Ground contact areas		Ground bearing pressure	
inches	meters	in ²	cm ²	psi	kg/cm ²
36	0.91	15,100	97 420	8.4	.61

Revolving Upperstructure

Frame

All-welded, precision machined unit.

Fuel tank

119 gallon (450 L) capacity.

Power transmission

All functions hydraulically powered allowing positive, precise control, with independent or simultaneous operation of all crane functions.

Engine Specifications	
Mitsubishi 6D24-TEB with oil filter, oil cooler, air cleaner, fuel filter, water separator, hour meter, tachometer and electrical shutdown.	
Number of cylinders	6
Bore and stroke - inch - (mm)	5.12" X 5.91" (130 X 150)
Piston displacement - (in ³) - (cm ³)	729 (11 945)
Engine rpm at full load speed Hi-idle rpm	2,000 2,200
Net engine horsepower at full load speed, (HP)	263 (196 kw)
Peak torque - foot pounds - (joule)	746 1 011
Peak torque - rpm	1,400
Electrical system Batteries	24 volt 2 - 12 volt

Hydraulic System

Hydraulic pumps

Two variable displacement piston pumps operating at 4,000 psi (281 kg/cm^2) powers travel, main drum, auxiliary drum, third drum and boom/hoist functions. One fixed displacement gear pump operating at 3,000 psi (211 kg/cm^2) powers swing. One fixed displacement gear pump operating at 3,600 psi (250 kg/cm^2) powers crawler retract cylinders and swing functions. One fixed displacement gear pump operating at 1,200 psi (85 kg/cm^2) powers pilot control system, clutches, brakes and pump controls.

Hydraulic reservoir

79 US gallon (300 L), equipped with sight level gauge.

Relief valves

Each function is equipped with relief valves to protect the circuit from overload or shock.

Brake valves

Travel circuit is provided with brake valves for all terrain travel capability.

Hydraulic filtration

Ten micron, full flow line filter furnished in control circuit. All oil is filtered prior to return to sump tank.

Hydraulic motors

Main, auxiliary and third hoist drums, boom hoist, swing and travel are powered by axial piston motors.

Counterbalance valves

Hoist motors are equipped with counterbalance valves to provide positive load lowering and prevent accidental load drop when hydraulic power is suddenly reduced.

Principal Operating Functions

Control system

Remote controlled hydraulic servo for main drum, auxiliary drum, third drum and travel. Mechanical linkage controls swing. Function speed is proportional to lever movement. Levers are adjustable for operator comfort.

Load hoisting and lowering

Main and auxiliary hoist drums are driven by individual axial piston motors and reduction gearing. Load hoisting or lowering is provided by actuating or reversing a hydraulic motor. Smooth, precise, power load lowering is attained with automatic hydraulic brake. The control lever provides two speeds for hoisting and lowering. Hoisting or lowering speeds are proportional to lever movement.

Freefall - The incorporation of power hydraulic controlled, two shoe clutches allows freefall operation of the main and auxiliary hoist drums for high cycle crane and duty cycle application. Mode selection switch on control panel allows operator to select the most productive operation mode.

Load hoist drums

Main (front) and auxiliary (rear) hoist drums are 18-11/16" (.47 m) root diameter grooved for 1" (25 mm) wire rope and mounted on anti-friction bearings.

Third operating drum

Optional; Pinned to front of main frame, 12-3/4" (.32 m) root diameter. Hydraulic winch type power up and down standard.

Optional; Same as third drum above but with controlled free spooling for use in pile driving applications.

Drum clutches

Speed-o-Matic® power hydraulic two-shoe clutches; internal expanding, lined shoes. Clutch spiders are splined to shafts; clutch drums are integral with hoist drums.

Load hoist clutches - Front and rear main drums - clutch drums 26" (.66 m) diameter, 5" (127 mm) face width. Swept area is 408 square inches (2 632 cm^2).

Drum brakes

External contracting band type; operated by foot pedal equipped with a locking latch. Operator may select automatic brake mode (spring applied, hydraulically released), which will apply brakes when the hoist control lever is in the neutral position.

Drum rotation indicators

Standard for front and rear drums. Audible-type indicators.

Drum locking pawl

Standard for front and rear drums; electrically actuated and prevents drum rotation in a lowering direction.

Load indicator

Standard: PAT E1-65 load indicator for main drum. See Auxiliary Equipment on page 8 for description and other available load indicators.

Anti two-block system

Standard: A switch mounted on the boom peak activates a buzzer to warn the operator of a two-block condition and simultaneously disengages hoist function while applying the hoist brakes.

Swing system

Independent, hydraulic swing is driven by dual axial piston motors through a gear reduction system.

Swing brake - Spring applied, hydraulically released; controlled by button on swing control lever.

Swing lock - Mechanically controlled, drop pin.

Swing speed - 0 to 3.0 r.p.m.

■ Boomhoist/lowering system

Independent, hydraulic boomhoist is driven by an axial piston motor through a gear reduction system. Boom hoisting or lowering is performed by actuating or reversing the motor.

■ Boomhoist drum

Single grooved lagging 10-11/16" (.27 m) root diameter.

■ Boomhoist drum locking pawl

Electrically operated.

■ Boomhoist brake

Spring applied, hydraulically released, multiple disc type brake. Brake is automatically applied when control lever is in neutral position.

Boomhoist limiting device - Restricts hoisting boom beyond recommended minimum radius.

■ Electrical system

24 volt negative ground system, with two 12-volt batteries. Standard lighting system includes: two 70 watt headlights mounted on machine front and one interior cab light.

■ Operator's cab

Full vision, modular compartment with safety glass panels. The completely independent cab is insulated against noise and vibration. Sliding operator's door, swing up roof window. Standard equipment includes: heater, defroster, windshield wiper, dry chemical fire extinguisher, sun visor, bubble-type level, fuel gauge, tachometer, hydraulic temperature gauge, engine oil pressure gauge, coolant temperature gauge, service monitor system, and E1-65 load indicator system.

■ Machinery cab

Hinged doors (two on right side, three on left side) for machinery access. Equipped with rooftop access ladder and electric warning horn.

■ Catwalks

Standard on both sides. Catwalks fold up for reduced travel width.

■ Gantry

Retractable high gantry is power lowered to reduce height for transport. May also be used for power raising or lowering of counterweight.

■ Gantry bail

Pinned to retractable high gantry. Six sheaves are provided for 14-part boomhoist wire rope reeving. Sheaves mounted on anti-friction bearings, sealed for lifetime lubrication.

■ Counterweights

Removable, held in position by bolts. Standard counterweight lowering system consists of retractable high gantry and hydraulic cylinders.

Counterweight "A" - 19,600 lbs. (8 891 kg)

Counterweight "B" - 20,100 lbs. (9 117 kg)

Booms and Jibs

■ Booms

Angle - Two piece basic boom 40' (12.19 m) long with open throat top section. Boom 48" (1.22 m) wide, 48" (1.22 m) deep at centerline of connections. Main chord angles are high strength, low alloy steel, 4" x 4" x 3/8" (101.6 mm x 101.6 mm x 9.53 mm).

Boompoint machinery - Five 18" (.46 m) root diameter head sheaves mounted on anti-friction bearings with rope and sheave guards standard for lift crane use. Three 22" (.56 m) root diameter head sheaves with roller guards are standard for dragline use.

Tubular - Two piece basic boom 40' (12.19 m) long with open throat top section. Boom 54" (1.37 m) wide, 44" (1.12 m) deep at centerline of connections. Alloy steel, round tubular chords 3" (76 mm) outside diameter.

Boompoint machinery - Five 18" (.46 m) root diameter head sheaves mounted on anti-friction bearings with rope and sheave guards standard. For lift crane use.

Items applicable to both booms:

Base section - 20' (6.10 m) long. Boom feet on 50" (1.27 m) centers. Lifting lugs on top side of base section to attach carrying links for boom assembly.

Boom extensions - Available in 10', 20' and 30' (3.05 m, 6.10 m, and 9.14 m) lengths with appropriate length pendants.

Boom connections - In-line tapered pins.

Boom top section - Open throat, 20' (6.10 m) long.

■ Angle jib

Angle - Basic two-piece 20' (6.10 m) long; 24" (.61 m) wide and 20" (.51 m) deep at connections. Alloy steel main chord angles, 2-1/2" x 2-1/2" x 5/16" (63 mm x 63 mm x 8 mm). Offsettable 0, 15, or 30 degrees relative to main boom angle.

Base section - 10' (3.05 m) long.

Jib extensions - available in 10' (3.05 m) lengths with appropriate length pendants.

Jib connections - bolted.

Jib tip section - 10' (3.05 m) long, one 18-1/2" (.47 m) root diameter sheave mounted on anti-friction bearings.

■ Jib mast

10' (3.05 m) high, mounted on jib base section. One deflector sheave mounted on anti-friction bearings, mounted within mast to guide whipline. Two equalizer sheaves mounted on top of mast - one for jib frontstay line, one for jib backstay line.

Jib staylines - Front and rear staylines vary in length depending on degree of jib offset from boom centerline. Backstay lines attached at bottom end of boom top section.

Jib stops - Dual, tubular telescoping type.

■ Tubular jib

Tubular - Basic two-piece 20' (6.10 m) long, 30" (.76 m) wide and 24" (.61 m) deep at connections. Alloy steel tubular chords 1-1/2" (38 mm) outside diameter. Offsettable 0, 15, or 30 degrees relative to main boom angle.

Base section - 10' (3.05 m) long.

Jib extensions - available in 10' (3.05 m) lengths with appropriate length pendants.

Jib connections - In-line, tapered pin connections.

Jib tip section - 10' (3.05 m) long, one 18" (.46 m) root diameter sheave mounted on anti-friction bearings.

Jib mast

10' (3.05 m) high, mounted on jib base section. Two deflector sheaves mounted within mast to guide whipline; mounted on anti-friction bearings. Two equalizer sheaves mounted on top of mast - one for jib frontstay line, one for jib backstay line.

Jib staylines - Front and rear staylines vary in length depending on degree of jib offset from boom center line; backstay lines attached at bottom end of boom top section.

Jib stops - Dual, tubular telescoping type.

Boom stops

Dual, tubular telescopic type.

Boom live mast

24' (7.32 m) long rectangular structure which supports boomhoist bridle and boom pendants. Boom live mast may be used as a short crane boom for machine assembly or dismantling. Standard with tubular boom attachment; *optional* for angle boom attachment.

Boomhoist bridle and spreader bar

Serves as connection for boom suspension system. Bridle contains seven 12-1/2" (.32 m) root diameter sheaves mounted on anti-friction bearings for 14-part boomhoist wire rope reeving. Auxiliary ball may be attached to bridle and contains two 15-7/8" (.40 m) root diameter bronze bushed sheaves to permit reeving wire rope suspension for use of boom live mast as short boom. Spreader bar provides attachment for boom main pendants.

Deflector rollers

Deflector roller and wear blocks deflect main and auxiliary load hoist wire rope over top side of boom. Roller is mounted on anti-friction bearings. One roller on top section and one wear block per extension is standard.

Auxiliary Equipment

Boom angle indicator

Pendulum type, mounted on operator's side of boom base section.

Load indicators

The **standard** PAT E1-65 load indicator for the main drum provides the operator with: main boom length, main boom angle, jib angle, jib length, operating mode, load radius, boom tip height, and anti-two block indicator.

Optional; PAT E1-65 load indicator for auxiliary drum. (Additional line rider required.)

Rated Capacity Limiters (Optional)

Optional; PAT DS-350 rated capacity limiter for main and auxiliary drums. (Additional line rider required for auxiliary drum.)

The optional rated capacity limiter system (RCL) provides the same information as the load indicator plus the crane's rated capacity at a particular setup with function kickout.

Includes a pre-warning light, audible alarm, and overload light.

Fairlead

Optional; full revolving type with barrel, sheaves and guide rollers mounted on anti-friction bearings.

Tagline

Optional; Rud-o-Matic®; double barrel, spring wound, drum-type.