

CAB BASE ASSEMBLY

Attn: John From: Rob

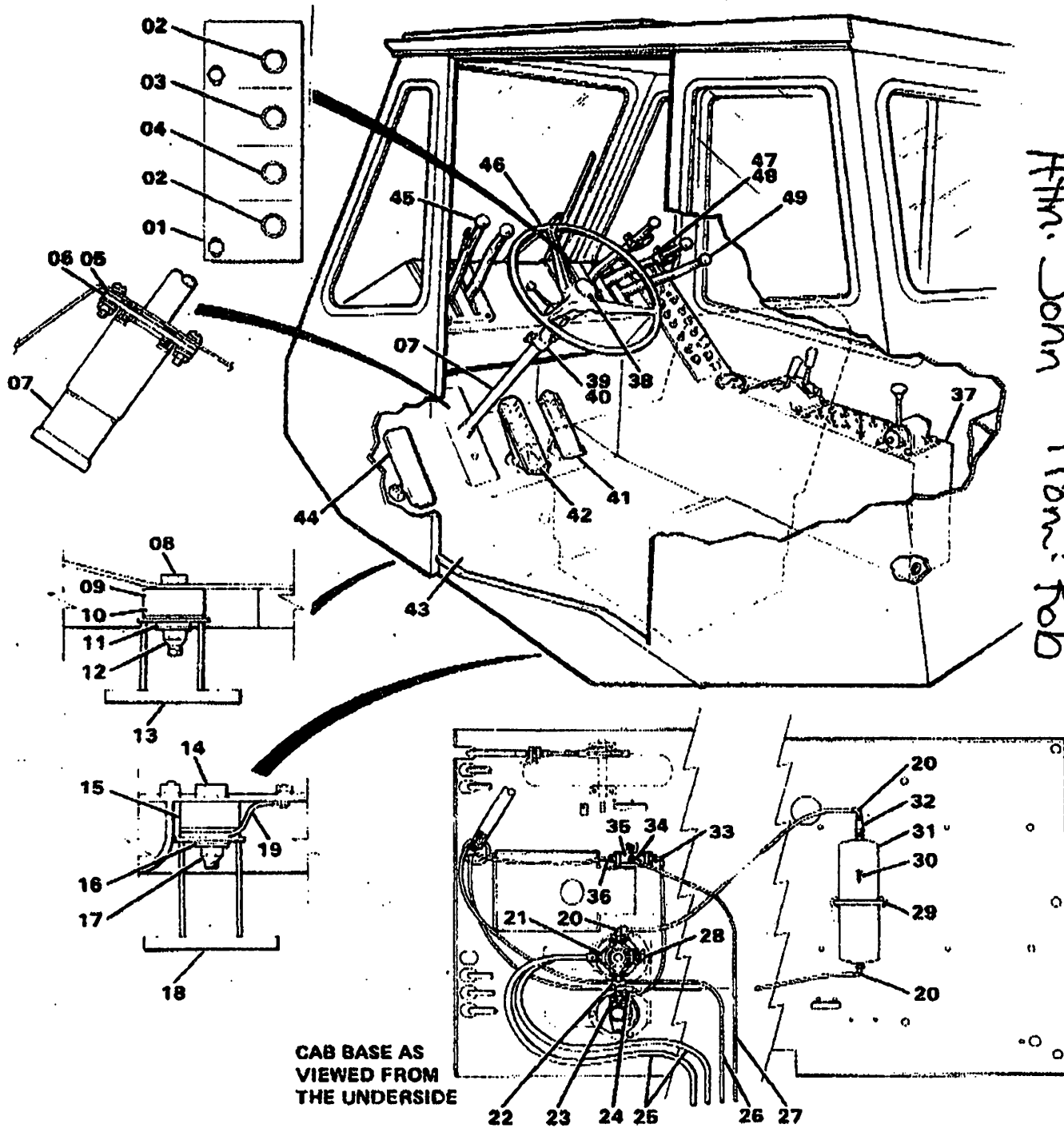

CAB BASE AS VIEWED FROM THE UNDERSIDE

Ref.	Part Number	Description	Quantity			
			Figure Number			
-	916J78-4	CAB BASE ASSEMBLY	4			
01	32Q958	. PLATE, Indicator light	1			
02	14Z348D3	. PLUG, Hole	2			
03	14Z348D2	. PLUG, Hole	1			
04	79Z2924D2	. LIGHT, Amber	1			

Group Page Rev.

2 5.3 001

Sheet 1 of 2

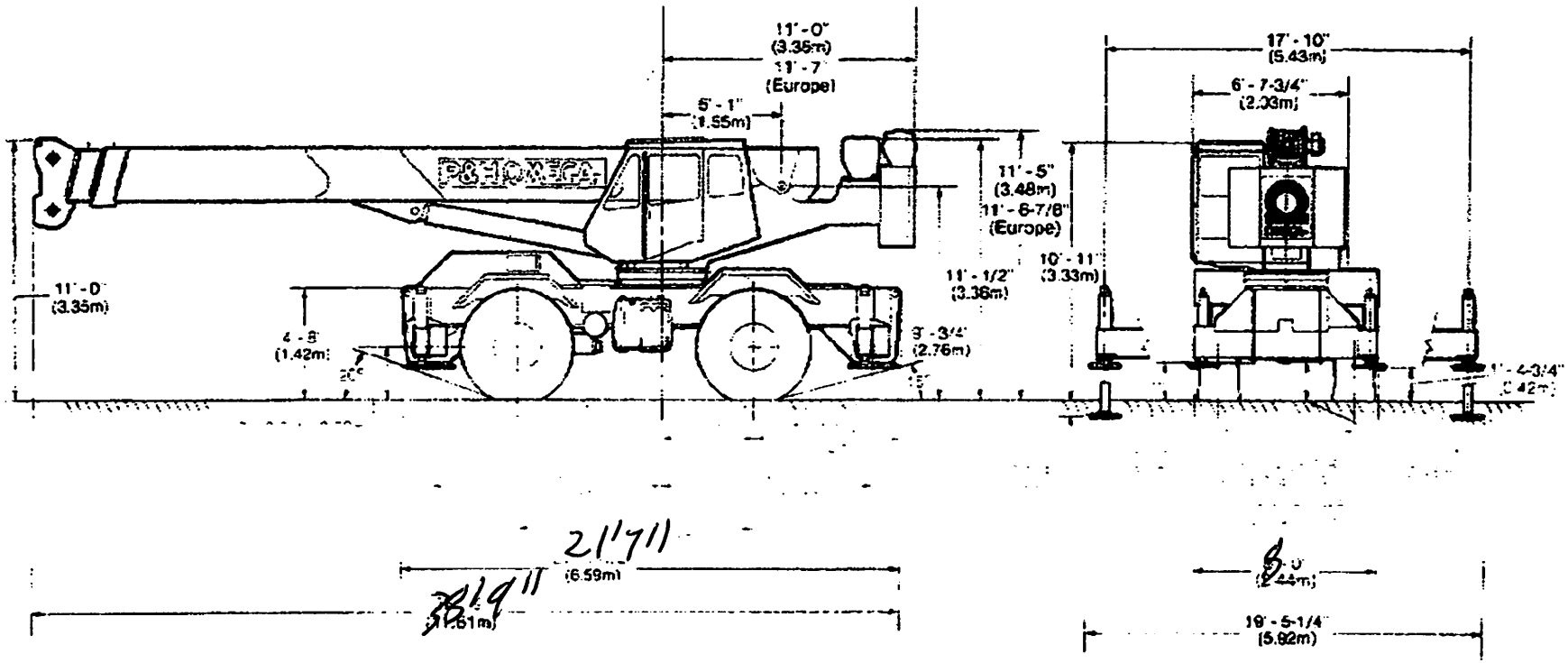

21'9" (6.51m)
 21'7" (6.59m)

6'-0" (1.83m)
 18'-5-1/4" (5.92m)

105J1266 Rev.

From: Rob
 Shaffer

Attn: John
 Hagan

2/2

